

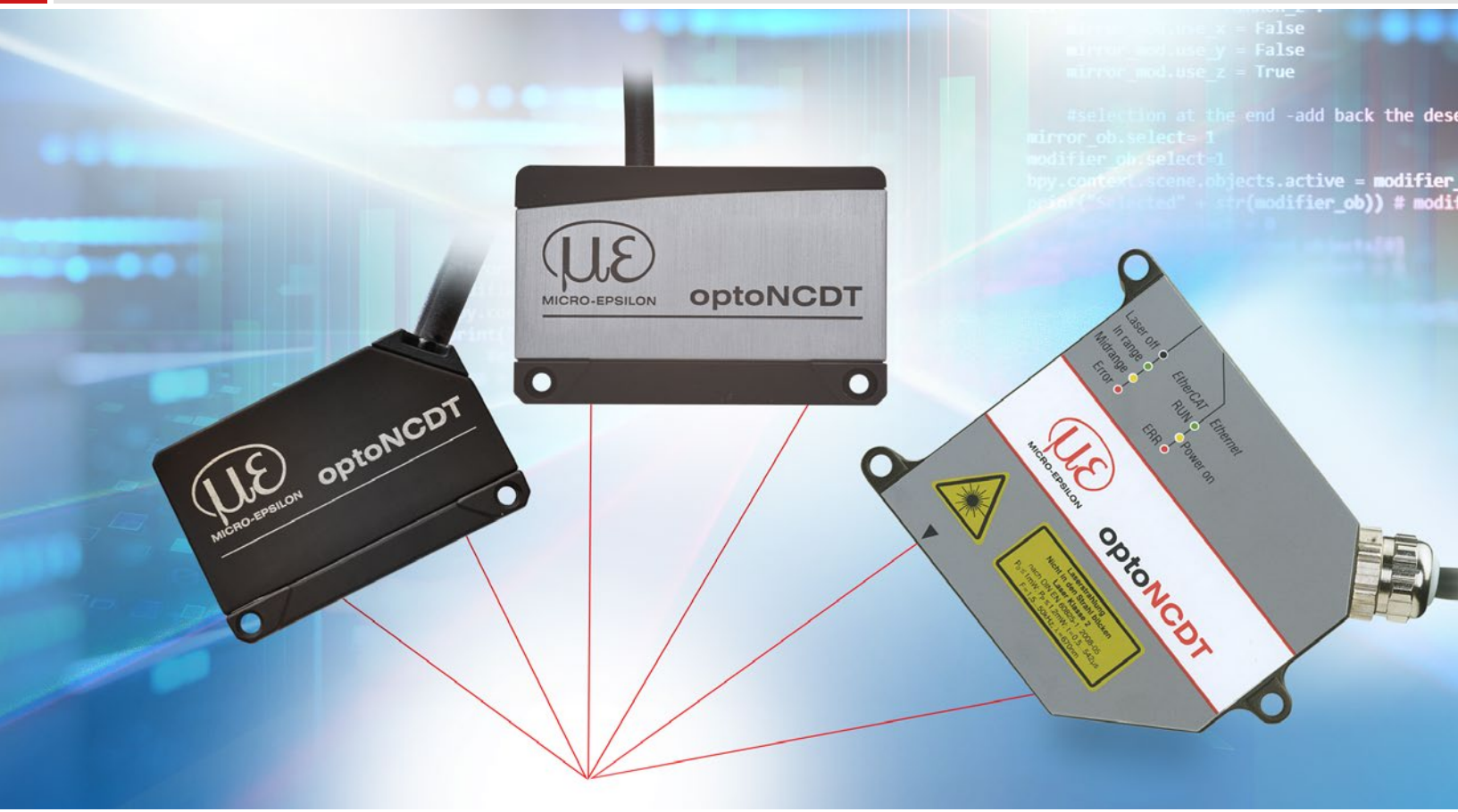

# More Precision

**optoNCDT** // Laser displacement sensors (triangulation)





# Connection possibilities

## optoNCDT 1220 / 1320 / 1420







### Sensors with integrated cable

Cable diameter:	5.40 ±0.2 mm
Drag chain:	no
Robot:	no
Temperature range:	-25 ... 105 °C (moving) -40 ... 105 °C (not moving)
Bending radius:	> 27 mm (fixed installation) > 54 mm (dynamic)

Sensor	Cables	Type	Connection possibilities and accessories	
ILD1220-xx	<b>Integrated cable</b> Length 2 m	Open ends	<b>Supply voltage connection</b> Power supply unit PS2020	
ILD1320-xx ILD1420-xx ILD1420-xxLL	<b>Integrated cable</b> Length 3 m		<b>Interface module of RS422 to USB</b> IF2001/USB IC2001/USB	
			<b>Interface module for Industrial Ethernet connection</b> IF2035-PROFINET IF2035-EIP IF2035-EtherCAT	



### Drag-chain suitable extension and adapter cables

Cable diameter:	6.0 ±0.2 mm
Drag chain:	yes
Robot:	no (optional on request)
Temperature range:	-40 ... 90 °C
Bending radius:	> 30 mm (fixed installation) > 60 mm (dynamic)

Sensor	Cables	Type	Connection possibilities and accessories	
ILD1420-xx ILD1420-xxLL	<b>Extension cable pigtail</b> Length 3 m / 6 m / 10 m / 15 m  <i>Art. no.      Designation</i> 29011067      PCF1420-3/I 29011068      PCF1420-6/I 29011069      PCF1420-10/I 29011070      PCF1420-15/I 29011071      PCF1420-3/U 29011072      PCF1420-6/U 29011073      PCF1420-10/U 29011074      PCF1420-15/U	Open ends	<b>Supply voltage connection</b> Power supply unit PS2020	
			<b>Interface module of RS422 to USB</b> IF2001/USB IC2001/USB	
			<b>Interface module for Industrial Ethernet connection</b> IF2035-PROFINET IF2035-EIP IF2035-EtherCAT	
			<b>Interface card for synchronous data acquisition</b> IF2008PCIe / IF2008E	
	<b>Adapter cable for PC interface card</b> Length 3 m / 6 m / 10 m  <i>Art. no.      Designation</i> 29011079      PCF1420-3/IF2008 29011088      PCF1420-6/IF2008 29011089      PCF1420-10/IF2008	Sub-D	<b>4-fold interface module from RS422 to USB</b> IF2004/USB	
	<b>Adapter cable for sensor calculation</b> Length 3 m / 6 m / 9 m  <i>Art. no.      Designation</i> 29011171      PCF1420-3/C-Box 29011172      PCF1420-6/C-Box 29011170      PCF1420-9/C-Box	Sub-D	<b>Controller for D/A conversion and evaluation of up to 2 sensor signals</b> Dual Processing Unit	
	<b>Adapter cable for sensor calculation</b> Length 2 m  <i>Art. no.      Designation</i> 29011149      PCE1420-2/M12	M12	<b>Interface module for Ethernet connection of up to 8 sensors</b> IF2008/ETH	





## Other cables

Cable diameter: 6.7 mm  
 Drag chain: yes  
 Robot: no  
 Temperature range: -40 ... 80 °C  
 Bending radius: > 27 mm (fixed installation)  
 > 51 mm (dynamic)

Input	Cables	Type	Connection possibilities and accessories	
2 x Sub-D (PCF1420-x/ IF2008)	<b>Adapter cable for the connection of two sensors per Sub-D connector</b> Length 0.1 m  <i>Art. no.</i> 2901528 <i>Designation</i> IF2008-Y-adapter cable  	Sub-D	<b>Interface card for synchronous data acquisition</b> IF2008PCIe / IF2008E  	<b>4-fold interface module from RS422 to USB</b> IF2004/USB  

# Powerful laser sensors for special applications

## optoNCDT 17x0 / optoNCDT 1910

-  Adjustable measuring rate up to 10 kHz
-  **INTER FACE** Analog (U/I) / RS422 / PROFINET / EtherNet/IP
-  **RTSC** Fast surface compensation
-  High repeatability
-  Ideal for large measurement distances

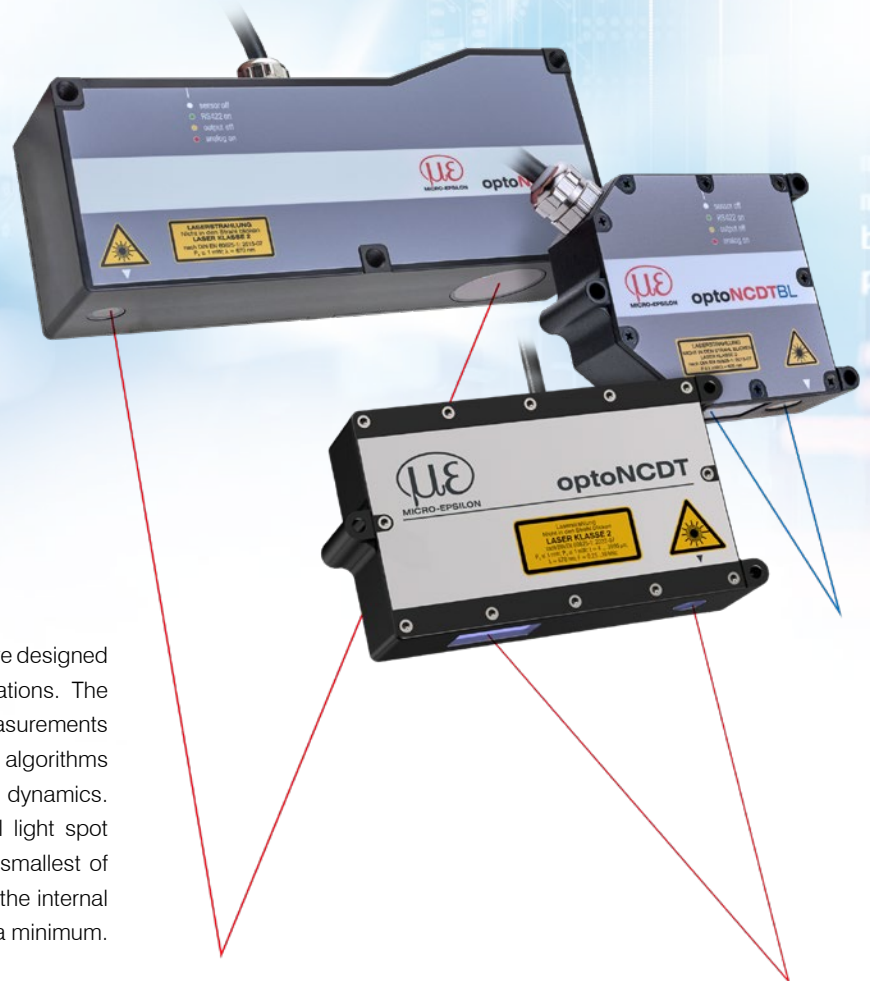

The optoNCDT 1910, 1710 and 1750 series laser sensors are designed for fast and precise measurements in industrial applications. The models are used for demanding surfaces and impress in measurements where large distances are required. Innovative evaluation algorithms and improved components enable high accuracy and dynamics. The high-performance optical system generates a small light spot onto the target which enables the detection of even the smallest of components reliably. The pigtail cable in conjunction with the internal controller reduces the installation effort for the sensors to a minimum.

### The intelligent exposure control for demanding surfaces

The optoNCDT 1750 sensors feature real-time surface compensation. The real-time surface compensation feature (RTSC) determines the amount of reflection from the target surface during continuous exposure and in real-time. The exposure time or the amount of light produced by the laser is optimally matched to the reflection characteristics of the target surface. This enables extremely reliable measurements even on reflecting surfaces. The optoNCDT 1910 sensors use Advanced Surface Compensation and are also highly resistant to ambient light.

### Ideal for industrial applications

Different output signals enable the integration of the sensor into plant and machine control systems. As well as analog voltage and current outputs, a digital interface provides distance information from the sensor. Due to the universal setting and evaluation possibilities, the sensors meet all the requirements for use in industrial applications.

Model	Technology	Measuring range	Repeatability	Linearity
optoNCDT 1750BL		2 - 750 mm	0.8 $\mu\text{m}$	from 0.06 %
optoNCDT 1750-DR		2 - 20 mm	0.1 $\mu\text{m}$	0.08 %
optoNCDT 1710		50 mm	from 7.5 $\mu\text{m}$	0.10 %
optoNCDT 1710BL		50 / 1000 mm	7.5 $\mu\text{m}$	from 0.10 %
optoNCDT 1760		1000 mm	from 7.5 $\mu\text{m}$	0.10 %
optoNCDT 1910		500 / 750 mm	from 20 $\mu\text{m}$	0.07 %

### Large distance and large measuring range

The optoNCDT long-range models are used to cover a large measuring range or to measure from a large distance to the target. The long-range laser sensors combine high accuracy and large measuring distances.

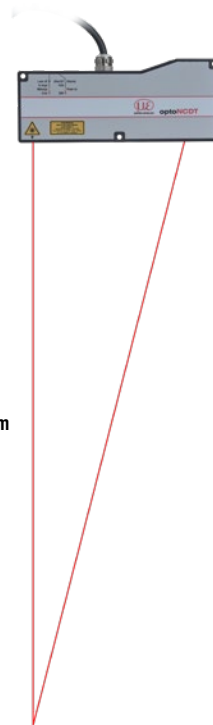

Measurement distances up to 2 m

### Application examples



Geometry testing of reflective glass parts

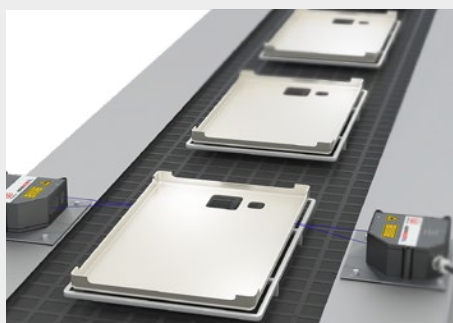

Position check of plastic components

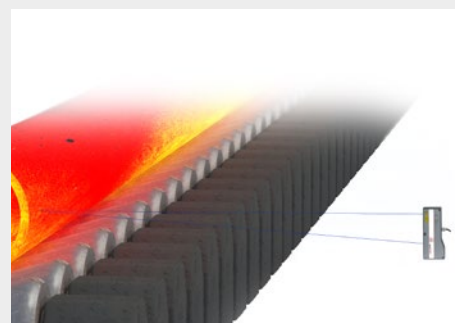

Position measurement of red-hot glowing pipes

# Technical data

## optoNCDT 17x0 Laser sensors for demanding objects

### optoNCDT 1750 (General technical data)

Model	ILD1750-xx	
Measuring rate <sup>[1]</sup>	6 adjustable stages: 7.5 kHz / 5 kHz / 2.5 kHz / 1.25 kHz / 625 Hz / 300 Hz	
Light source	Semiconductor laser < 1 mW, 670 nm (red)	
Laser class	Class 2 in accordance with DIN EN 60825-1: 2022-07	
Permissible ambient light	10,000 lx	
Supply voltage	11 ... 30 VDC	
Power consumption	< 3 W (24 V)	
Signal input	1 x HTL/TTL laser on/off; 1 x HTL/TTL multi-function input: trigger in, slave in, zero setting, mastering, teach-in; 1 x RS422 synchronization input: trigger in, sync in, master/slave, master/slave alternating	
Digital interface <sup>[2]</sup>	RS422 (16 bit) / EtherCAT / PROFINET / EtherNet/IP	
Analog output	4 ... 20 mA / 0 ... 5 V / 0 ... 10 V (16 bit, freely scalable within the measuring range)	
Switching output	2x switching outputs (error & limit value): npn, pnp, push pull	
Connection	integrated pigtail 0.25 m with 14-pin ODU connector, min. bending radius 30 mm when firmly installed; optional extension to 3 m / 10 m possible (see accessories for suitable connection cables)	
Installation	Screw connection via three mounting holes	
Temperature range	Storage	-20 ... +70 °C (non-condensing)
	Operation	0 ... +50 °C (non-condensing)
Shock (DIN EN 60068-2-27)	15 g / 6 ms in 3 axes	
Vibration (DIN EN 60068-2-6)	2 g / 20 ... 500 Hz	
Protection class (DIN EN 60529)	IP65	
Material	Zinc die-cast housing	
Weight	approx. 550 g (incl. pigtail)	
Control and indicator elements <sup>[3]</sup>	Select & function keys: interface selections, mastering (zero), teach, presets, quality slider, frequency selection, factory settings; web interface for setup: application-specific presets, peak selection, video signal, freely selectable averaging possibilities, data reduction, setup management 2 x color LEDs for power / status	

<sup>[1]</sup> Factory setting: measuring rate 4 kHz, modifying the factory setting requires the IF2001/USB converter (see accessories)

<sup>[2]</sup> EtherCAT, PROFINET and EtherNet/IP require connection via interface module (see accessories)

<sup>[3]</sup> Access to web interface requires connection to PC via IF2001/USB (see accessories)



## Blue laser - optoNCDT 1750BL

Model		ILD1750-20BL	ILD1750-200BL	ILD1750-500BL	ILD1750-750BL
Measuring range		20 mm	200 mm	500 mm	750 mm
Start of measuring range		40 mm	100 mm	200 mm	200 mm
Mid of measuring range		50 mm	200 mm	450 mm	575 mm
End of measuring range		60 mm	300 mm	700 mm	950 mm
Linearity <sup>[1]</sup>		< ±12 μm	< ±160 μm	< ±350 μm	< ±670 μm
		< ±0.06 % FSO	< ±0.08 % FSO	< ±0.07 % FSO	< ±0.09 % FSO
Repeatability <sup>[2]</sup>		0.8 μm	15 μm	20 μm	45 μm
Light spot diameter <sup>[3]</sup>	SMR	320 μm	1300 μm	1500 μm	1500 μm
	MMR	45 μm			
	EMR	320 μm			
Light source	Semiconductor laser <1 mW, 405 nm (blue violet)				
Material	Die-cast zinc housing			Aluminum housing	

<sup>[1]</sup> FSO = Full Scale Output; the specified data apply to white, diffuse reflecting surfaces (Micro-Epsilon reference ceramic for ILD sensors)

<sup>[2]</sup> Measuring rate 5 kHz, median 9

<sup>[3]</sup> ±10 %; SMR = Start of measuring range; MMR = Mid of measuring range; EMR = End of measuring range



## Direct reflection - optoNCDT 1750DR

Model		ILD1750-2DR	ILD1750-10DR	ILD1750-20DR
Measuring range		2 mm	10 mm	20 mm
Start of measuring range		24 mm	30.5 mm	53.5 mm
Mid of measuring range		25 mm	35.5 mm	63.5 mm
End of measuring range		26 mm	40.5 mm	73.5 mm
Linearity <sup>[1]</sup>		< ±1.6 μm	< ±6 μm	< ±12 μm
		< ±0.08 % FSO		
Repeatability <sup>[2]</sup>		0.1 μm	0.4 μm	0.8 μm
Measuring angle		20°	17.6°	11.5°
Light spot diameter <sup>[3]</sup>	SMR	80 μm	110 μm	320 μm
	MMR	35 μm	50 μm	45 μm
	EMR	80 μm	110 μm	320 μm

<sup>[1]</sup> FSO = Full Scale Output; the specified data apply to white, diffuse reflecting surfaces (Micro-Epsilon reference ceramic for ILD sensors)

<sup>[2]</sup> Measuring rate 5 kHz, median 9

<sup>[3]</sup> ±10 %; SMR = Start of measuring range; MMR = Mid of measuring range; EMR = End of measuring range

# Technical data

## optoNCDT 17x0 Laser sensors for large measuring ranges



### Long range - optoNCDT 1710

Model		ILD1710-50
Measuring range		50 mm
Start of measuring range		550 mm
Mid of measuring range		575 mm
End of measuring range		600 mm
Measuring rate		4 adjustable stages: 2.5 kHz / 1.25 kHz / 625 Hz / 312.5 Hz
Linearity <sup>[1]</sup>		< ±50 μm
		< ±0.1 % FSO
Resolution <sup>[2]</sup>		7.5 μm
Light spot diameter <sup>[3]</sup>	SMR	400 x 500 μm
	MMR	
	EMR	
Light source		Semiconductor laser < 1 mW, 670 nm (red)
Laser class		Class 2 in accordance with DIN EN 60825-1: 2022-07
Permissible ambient light		10,000 lx
Supply voltage		11 ... 30 VDC
Max. current consumption		150 mA (24 V)
Signal input		Zero, laser on/off
Digital interface		RS422 (14 bit)
Analog output		4 ... 20 mA / 0 ... 10 V
Switching output		1 x error / 2 x limit values (configurable)
Connection		integrated pigtail 0.25 m with 14-pin ODU plug, min. bending radius 30 mm when firmly installed (see accessories for suitable connection cable)
Installation		Screw connection via three mounting holes
Temperature range	Storage	-20 ... +70 °C (non-condensing)
	Operation	0 ... +50 °C (non-condensing)
Shock (DIN EN 60068-2-27)		15 g / 6 ms in 3 axes
Vibration (DIN EN 60068-2-6)		2 g / 20 ... 500 Hz
Protection class (DIN EN 60529)		IP65
Material		Aluminum housing
Weight		approx. 800 g (incl. pigtail)
Control and display elements		Select & function keys: output type, measuring rate, type of averaging, averaging number, error analog, synchronization, operation mode, trigger mode, baud rate, data format; display of measured values via PC with sensorTOOL; 5x color LEDs for status display

<sup>[1]</sup> FSO = Full Scale Output; the specified data apply to white, diffuse reflecting surfaces (Micro-Epsilon reference ceramic for ILD sensors)

<sup>[2]</sup> Measuring rate 2.5 kHz, without averaging

<sup>[3]</sup> ±10 %; SMR = Start of measuring range; MMR = Mid of measuring range; EMR = End of measuring range





## Long range / Blue laser - optoNCDT 1710BL

Model		ILD1710-50BL	ILD1710-1000BL
Measuring range		50 mm	1 000 mm
Start of measuring range		550 mm	1 000 mm
Mid of measuring range		575 mm	1 500 mm
End of measuring range		600 mm	2 000 mm
Measuring rate		4 adjustable stages: 2.5 kHz / 1.25 kHz / 625 Hz / 312.5 Hz	
Linearity <sup>[1]</sup>		< ±50 μm	< ±1000 μm
		< ±0.1 % FSO	
Resolution <sup>[2]</sup>		7.5 μm	100 μm
Light spot diameter <sup>[3]</sup>	SMR	400 x 500 μm	2500 ... 5000 μm
	MMR		
	EMR		
Light source		Semiconductor laser <1 mW, 405 nm (blue violet)	
Laser class		Class 2 in accordance with DIN EN 60825-1: 2022-07	
Permissible ambient light		10,000 lx	
Supply voltage		11 ... 30 VDC	
Max. current consumption		150 mA (24 V)	
Signal input		Zero, laser on/off	
Digital interface		RS422 (14 bit)	
Analog output		4 ... 20 mA / 0 ... 10 V	
Switching output		1 x error / 2 x limit values (configurable)	
Connection		integrated pigtail 0.25 m with 14-pin ODU plug, min. bending radius 30 mm when firmly installed (see accessories for suitable connection cable)	
Installation		Screw connection via three mounting holes	
Temperature range	Storage	-20 ... +70 °C (non-condensing)	
	Operation	0 ... +50 °C (non-condensing)	
Shock (DIN EN 60068-2-27)		15 g / 6 ms in 3 axes	
Vibration (DIN EN 60068-2-6)		2 g / 20 ... 500 Hz	
Protection class (DIN EN 60529)		IP65	
Material		Aluminum housing	
Weight		approx. 800 g (incl. pigtail)	
Control and display elements		Select & function keys: output type, measuring rate, type of averaging, averaging number, error analog, synchronization, operation mode, trigger mode, baud rate, data format; display of measured values via PC with sensorTOOL; 5x color LEDs for status display	

<sup>[1]</sup> FSO = Full Scale Output; the specified data apply to white, diffuse reflecting surfaces (Micro-Epsilon reference ceramic for ILD sensors)

<sup>[2]</sup> Measuring rate 2.5 kHz, without averaging

<sup>[3]</sup> ±10 %; SMR = Start of measuring range; MMR = Mid of measuring range; EMR = End of measuring range

# Technical data

## optoNCDT 17x0 Laser sensors for large measuring ranges



### Long-Range - optoNCDT 1760

Model		ILD1760-1000
Measuring range		1 000 mm
Start of measuring range		1 000 mm
Mid of measuring range		1 500 mm
End of measuring range		2 000 mm
Measuring rate <sup>[1]</sup>		6 adjustable stages: 7.5 kHz / 5 kHz / 2.5 kHz / 1.25 kHz / 625 Hz / 300 Hz
Linearity <sup>[2]</sup>		< ±1000 μm < ±0.1 % FSO
Repeatability <sup>[3]</sup>		100 μm
Light spot diameter <sup>[4]</sup>	SMR	2500 ... 5000 μm
	MMR	
	EMR	
Light source		Semiconductor laser < 1 mW, 670 nm (red)
Laser class		Class 2 in accordance with DIN EN 60825-1: 2022-07
Permissible ambient light		10,000 lx
Supply voltage		11 ... 30 VDC
Max. current consumption		150 mA (24 V)
Signal input		1 x HTL/TTL laser on/off; 1 x HTL/TTL multi-function input: trigger in, slave in, zero setting, mastering, teach-in; 1 x RS422 synchronization input: trigger in, sync in, master/slave, master/slave alternating
Digital interface <sup>[5]</sup>		RS422 (16 bit) / EtherCAT / PROFINET / EtherNet/IP
Analog output		4 ... 20 mA / 0 ... 5 V / 0 ... 10 V (16 bit, freely scalable within the measuring range)
Switching output		2x switching outputs (error & limit value): npn, pnp, push pull
Connection		integrated pigtail 0.25 m with 14-pin ODU connector, min. bending radius 30 mm when firmly installed; optional extension to 3 m / 10 m possible (see accessories for suitable connection cables)
Installation		Screw connection via three mounting holes
Temperature range	Storage	-20 ... +70 °C (non-condensing)
	Operation	0 ... +50 °C (non-condensing)
Shock (DIN EN 60068-2-27)		15 g / 6 ms in 3 axes
Vibration (DIN EN 60068-2-6)		2 g / 20 ... 500 Hz
Protection class (DIN EN 60529)		IP65
Material		Aluminum housing
Weight		approx. 800 g (incl. pigtail)
Control and indicator elements <sup>[6]</sup>		Select & function keys: interface selections, mastering (zero), teach, presets, quality slider, frequency selection, factory settings; web interface for setup: application-specific presets, peak selection, video signal, freely selectable averaging possibilities, data reduction, setup management 2 x color LEDs for power / status

<sup>[1]</sup> Factory setting 5 kHz, modifying the factory setting requires the IF2001/USB converter (see accessories)

<sup>[2]</sup> FSO = Full Scale Output; the specified data apply to white, diffuse reflecting surfaces (Micro-Epsilon reference ceramic for ILD sensors)

<sup>[3]</sup> Measuring rate 5 kHz, median 9

<sup>[4]</sup> ±10 %; SMR = Start of measuring range; MMR = Mid of measuring range; EMR = End of measuring range

<sup>[5]</sup> EtherCAT, PROFINET and EtherNet/IP require connection via interface module (see accessories)

<sup>[6]</sup> Access to web interface requires connection to PC via IF2001/USB (see accessories)