











# More Precision

**interferoMETER** // High precision absolute interferometers



# High precision inline wafer thickness measurement interferoMETER 5420

-  Nanometer-precise thickness measurement from 0.05 to 1.05 mm (SI wafers)
-  Undoped, doped and highly doped wafers
-  Multi-peak: up to 5 layers in one measurement
-  High resolution 1 nm
-  Measuring rate up to 6 kHz for high speed measurements
-  Ethernet / EtherCAT / RS422 / PROFINET / EtherNet/IP
-  Easy configuration via web interface
-  Flexible industrial integration

TH



## Stable wafer thickness measurement in inline processes

The IMS5420-TH absolute interferometer opens up new perspectives in the industrial thickness measurement of monocrystalline silicon wafers and silicon carbide wafers and comparable materials that are transparent for a wavelength range of 1,100 nm. Due to its broadband superluminescent diode (SLED), the IMS5420-TH can be used for undoped, doped and highly doped SI wafers. In wafer thickness measurements, the IMS5420-TH impresses with an excellent price/performance ratio.

Due to the optical transparency of silicon wafers, interferometers can precisely detect the thickness in the wavelength range of 1,100 nm. This makes it possible to measure the thickness of wafers up to 1.05 mm. The measurable thickness of air gaps is even up to 4 mm.

The absolute interferometer achieves signal stability in the submicrometer range. The thickness can be measured from a distance of 24 mm which makes this measuring system ideally suited for inline measurements.

The measuring system is available as a thickness measuring system or as a multi-peak thickness measuring system. The multi-peak system measures thicknesses of up to five layers, e.g., wafer thickness, air gap, films and coatings.

The IMS5420/IP67 controller with IP67 and stainless steel housing is available for thickness measurements in challenging environmental conditions such as wafer lapping.

Doping	Element	Specific resistance
P-	Boron	1-150 Ω·cm
N-	Phosphorus	1-200 Ω·cm
P+	Boron	0.01-0.02 Ω·cm
P++	Boron	0.005-0.01 Ω·cm

20 μm light spot



With multi-layer thickness measurements of silicon wafers, up to 5 layers from 50 to 1050 μm can be detected.



Due to their compact size, these sensors can also be integrated into restricted spaces.

The measuring range for air gap measurement (with refractive index ~1) is 0.2 to 4.0 mm and for wafer thickness measurement (with refractive index ~3.82) 50 μm to 1.05 mm.

# Controller

Model	IMS5420-TH	IMS5420MP-TH	IMS5420IP67-TH	IMS5420IP67MP-TH
Resolution <sup>[1]</sup>	< 1 nm			
Measuring rate	continuously adjustable from 100 Hz to 6 kHz			
Linearity <sup>[2]</sup>	< ±100 nm	< ±100 nm with one layer; < ±200 nm for other layers	< ±100 nm	< ±100 nm with one layer; < ±200 nm for other layers
Temperature stability	temperature compensated, stability < ±50 ppm between +10 ... +50 °C			
Multi-peak measurement	1 layer	up to 5 layers	1 layer	up to 5 layers
Light source	NIR-SLED, narrow wavelength band at approx. 1100 nm; pilot laser: laser LED, wavelength 635 nm		NIR-SLED, narrow wavelength band at approx. 1100 nm	
Laser class	Class 1 according to DIN EN 60825-1: 2022-07; Pilot laser: Class 1, power (< 0.2 mW)		Class 1 in accordance with DIN EN 60825-1: 2022-07	
Supply voltage	24 VDC ±15 %			
Power consumption	approx. 10 W (24 V)			
Signal input	Sync in, trigger in, 2x encoders (A+, A-, B+, B-, index)		-	
Digital interface	Ethernet / EtherCAT / RS422 / PROFINET <sup>[3]</sup> / EtherNet/IP <sup>[3]</sup>		Ethernet / RS422 / PROFINET <sup>[3]</sup> / EtherNet/IP <sup>[3]</sup>	
Analog output	4 ... 20 mA / 0 ... 10 V (16 bit D/A converter)		-	
Switching output	Error1-Out, Error2-Out		-	
Digital output	sync out		-	
Connection	Optical	Pluggable fiber optic cable via E2000 socket (controller); see accessories for cable lengths; bending radius: static 30 mm, dynamic 40 mm		Pluggable optical fiber via IP9 SC socket, standard lengths 1 m and 2 m, other cable lengths on request; bending radius: static 45 mm, dynamic 60 mm
	Electrical	3-pin supply terminal strip; encoder connection (15-pin, HD-sub socket, max. cable length 3 m, 30 m with external encoder supply); RS422 connection socket (9-pin, Sub-D, max. cable length 30 m); 3-pin output terminal strip (max. cable length 30 m); 11-pin I/O terminal strip (max. cable length 30 m); RJ45 socket for Ethernet (out) / EtherCAT (in/out) (max. cable length 100 m)		4-pin M12 connector for supply; RS422 connector (5-pin, M12, max. cable length 30 m); RJ45 socket for Ethernet (out) / EtherCAT (in/out) (max. cable length 100 m)
Mounting	Free-standing, DIN rail mounting		Through bores	
Temperature range	Storage	-20 ... +70 °C		
	Operation	+10 ... +50 °C		
Shock (DIN EN 60068-2-27)	15 g / 6 ms in XY axis, 1000 shocks each			
Vibration (DIN EN 60068-2-6)	2 g / 20 ... 500 Hz in XY axis, 10 cycles each			
Protection class (DIN EN 60529)	IP40		IP67	
Material	Aluminum housing, passive cooling		Stainless steel housing	
Control and indicator elements	Multifunction button: two adjustable functions and reset to factory settings after 10 s; web interface for setup: selectable presets, freely selectable averaging, data reduction, setup management; 6 x color LEDs for intensity, range, SLED, pilot laser, status and power; pilot laser: can be switched on for sensor alignment		Web interface for setup: selectable presets, freely selectable averaging, data reduction, setup management; power LED	

<sup>[1]</sup> All data at constant ambient temperature (22 ±3 °C). Measuring rate 0.5 kHz, moving average over 64 values, measured on an approx. 0.8 mm thick silicon (2 sigma) polished on both sides

<sup>[2]</sup> Maximum thickness deviation when measuring on an approx. 0.8 mm thick silicon polished on both sides (n=3.8) when passing through the measuring range

<sup>[3]</sup> Optional connection via interface module (see accessories)

# Sensors for wafer thickness measurements

## interferoMETER 5420



Sensors for the IMS5420 controller for wafer thickness measurement

Model		IMP TH24
Working distance		24 mm ±3.0 mm
Measuring range (Thickness)	Silicon	0.05 ... 1.05 mm <sup>[1]</sup>
	Air	0.2 ... 4 mm <sup>[2]</sup>
Temperature stability		temperature compensated, stability < ±50 ppm between +10 ... +50 °C
Light spot diameter <sup>[3]</sup>		20 μm
Measuring angle <sup>[4]</sup>		±1.5°
Connection	Optical	Pluggable fiber optic cable via FC socket (sensor); see accessories for cable lengths; bending radius: static 30 mm, dynamic 40 mm
Mounting		Radial clamping, mounting adapter (see accessories)
Temperature range	Storage	-20 ... +70 °C
	Operation	+10 ... +50 °C (front side)
Dimensions	Diameter	Ø10
	Length	25 mm
Protection class (DIN EN 60529)		IP65 (optional IP67) <sup>[5]</sup>
Vacuum		on request UHV (cable and sensor)
Material		Stainless steel

<sup>[1]</sup> All data at constant ambient temperature (22 ±3 °C). Measuring range at n=3.82 (silicon); measurable thickness depends on doping (see table)

<sup>[2]</sup> For air gap measurement between two glass plates (n~1) the measuring range is 0.2 ... 4 mm. The measuring object must be within the working distance.

<sup>[3]</sup> With a working distance of 24 mm (TH-24) or 17.5 mm (204)

<sup>[4]</sup> Maximum sensor tilt angle that produces a usable signal on an approx. 0.8 mm thick silicon in the mid of the measuring range. The accuracy decreases when approaching the limit values.

<sup>[5]</sup> Other protection classes on request

# Dimensions

## IMS5420 controller

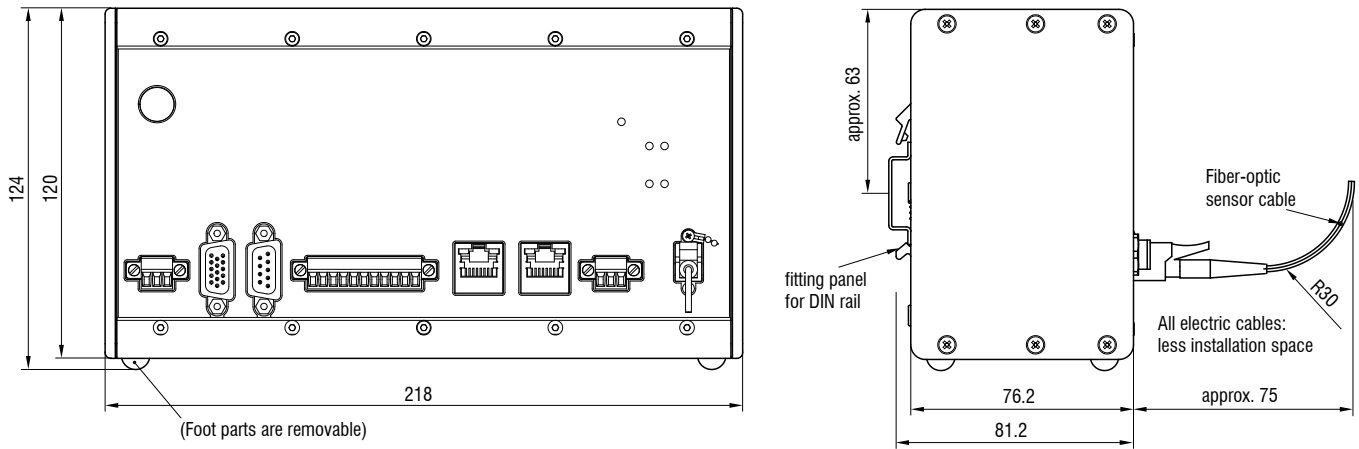

## IMS5420/IP67-TH24 Measuring system with controller housing made of stainless steel and protection class IP67

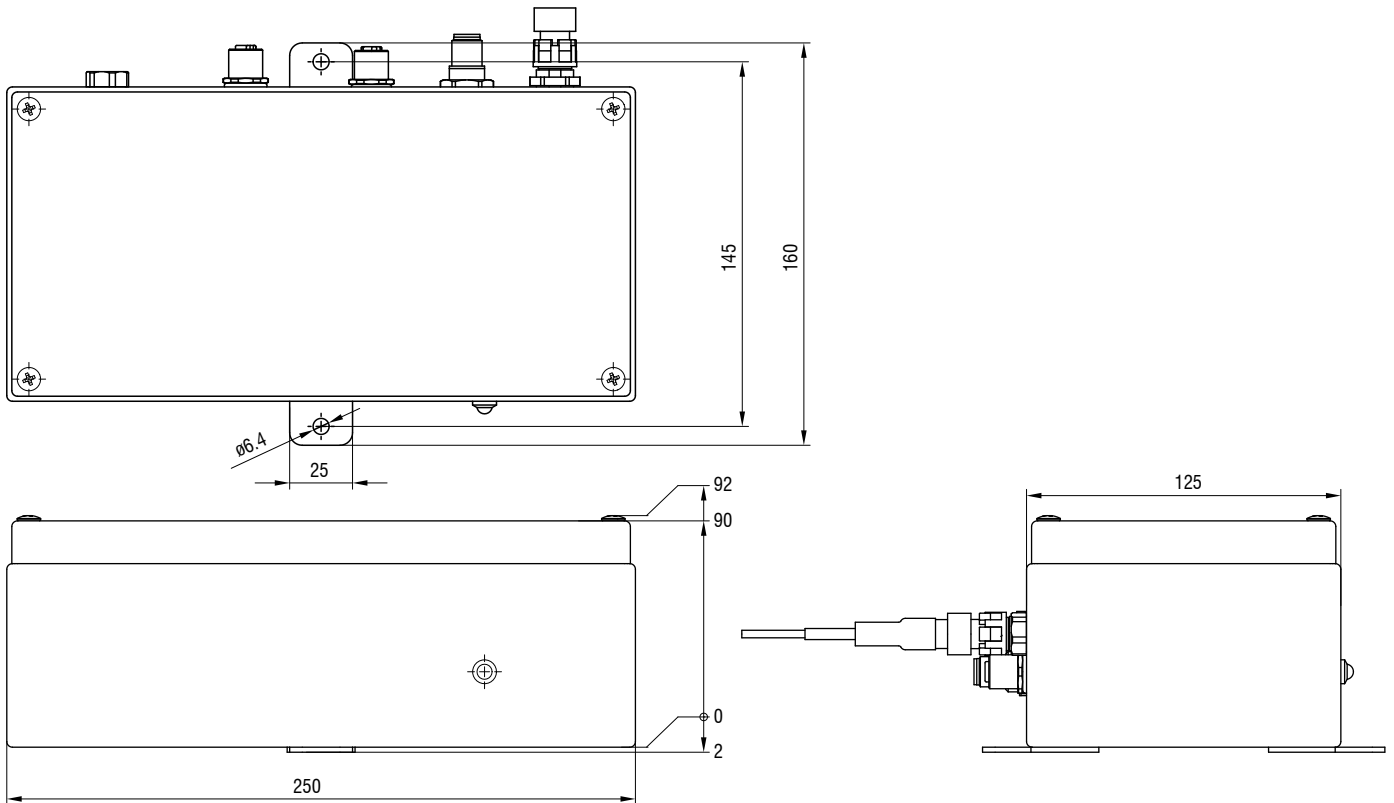

## Thickness sensor IMP TH24

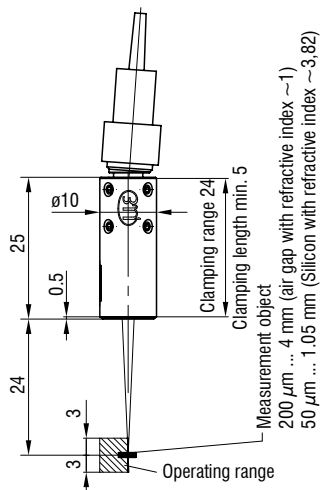

# Connection possibilities interferoMETER

## Connection options for the IMS5400 and IMS5600 controllers

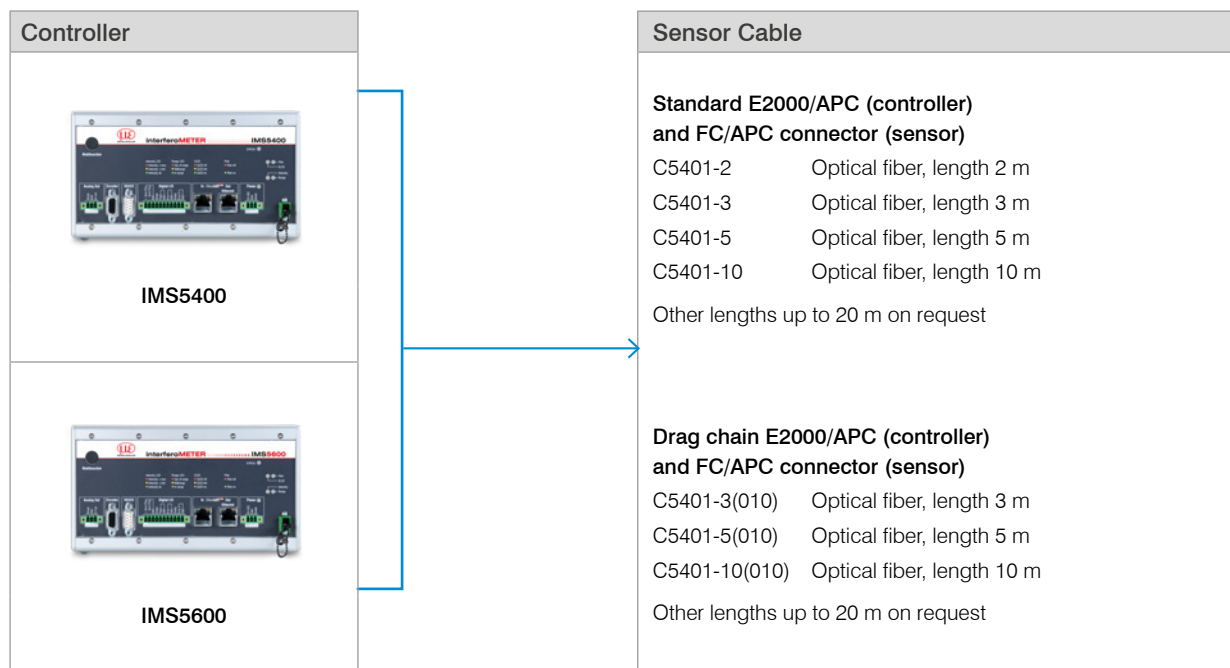

## Connection options for the IMS5420 controller

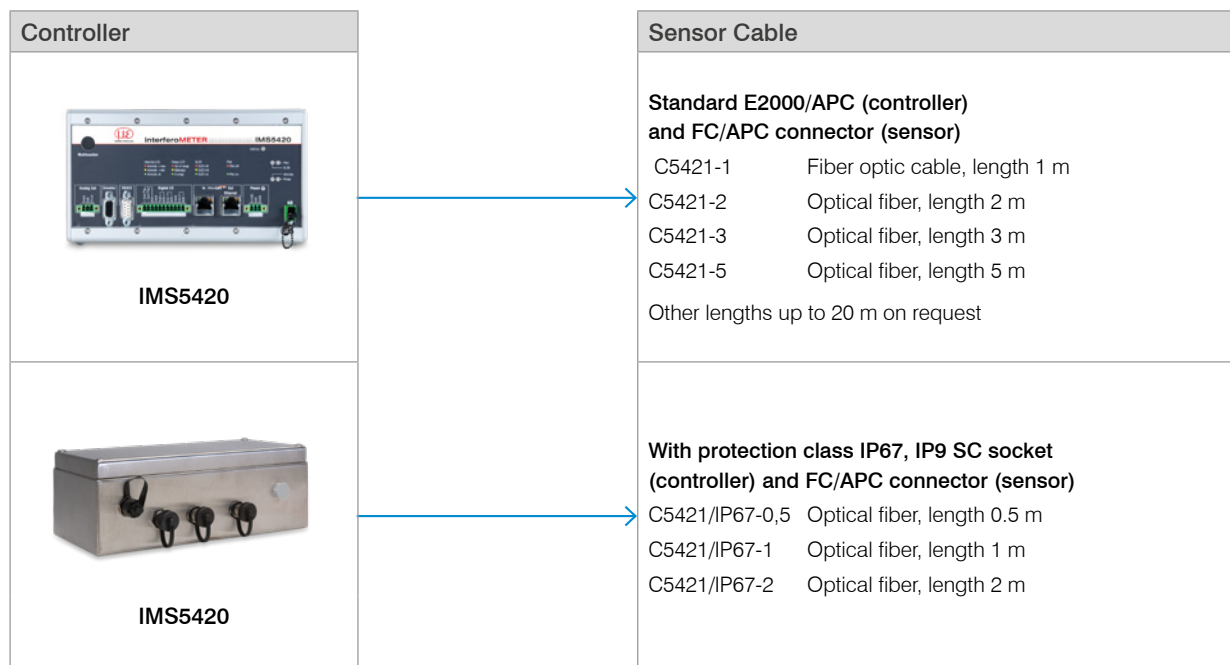

## Connector

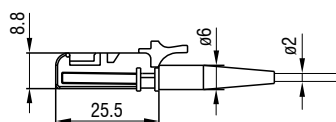

E2000/APC Standard connector

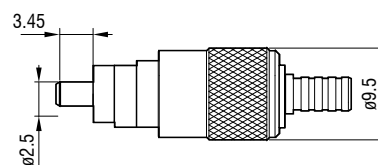
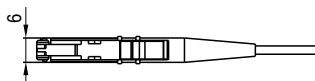

FC/APC Standard connector

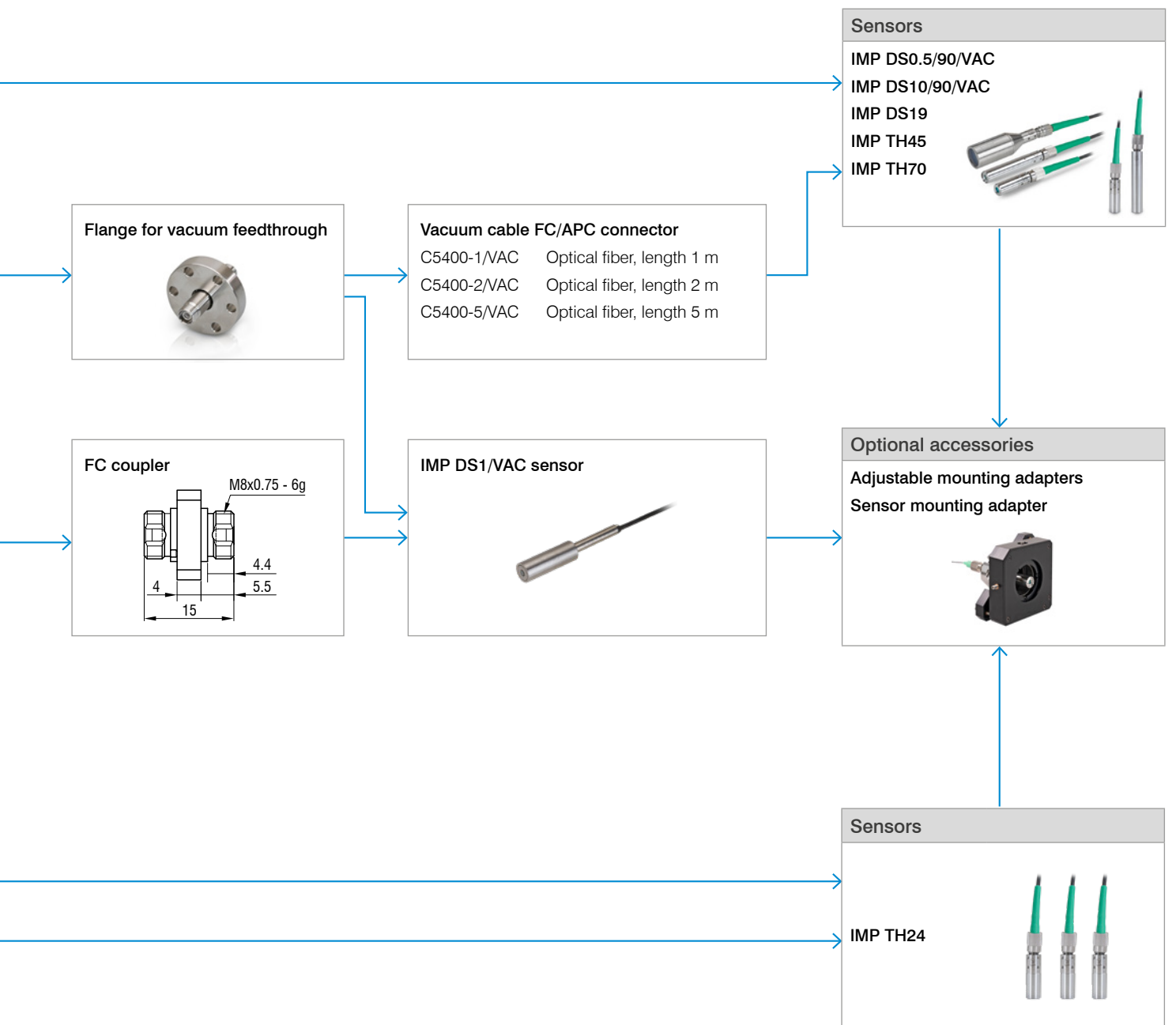

## Article designations

**DS** IMS5xxx-DSxx  
distance measuring system  
(e.g. IMS5600MP-DS19)

IMS5xxx	-DSxx
<b>Controller model</b>	<b>Sensor model</b>
IMS5400	DS1/VAC
IMS5400MP	DS19
IMS5600	DS19/VAC
IMS5600MP	DS0.5/90/VAC DS10/90/VAC

**TH** IMS5xxx-THxx  
thickness measuring system  
(e.g. IMS5400-TH45/VAC)

IMS5xxx	-THxx
<b>Controller model</b>	<b>Sensor model</b>
IMS5400	TH45
IMS5400MP	TH45/VAC TH70

**TH** IMS5420xx-THxx  
wafer thickness measuring system  
(e.g. IMS5420-TH24)

IMS5xxx	-THxx
<b>Controller model</b>	<b>Sensor model</b>
IMS5420	TH24
IMS5420MP	TH24(204)
IMS5420IP67	
IMS5420IP67MP	



# Optional accessories

## interferoMETER

### Flange for vacuum feedthrough

C5405/VAC/1/CF16 CF flange

C5405/VAC/1/KF16 KF flange

### Mounting adapter

MA5400- 10 Mounting adapter for IMP-DS19/ -TH45

MA5400- 20 Mounting adapter for IMP-TH70

MA2402-4 Mounting adapter for IMP-DS1

### Other accessories

SC2471-x/IF2008 IMC5400/5600 connector cable+ IF2008/PCIE, length 3 m / 10 m

SC2471-x/RS422/OE IMC5400/5600 interface cable + IF2001/USB, length 3 m / 10 m

IF2001/USB RS422/USB converter

IF2008/PCIE Interface card

IF2035/PNET Interface module for PROFINET integration

IF2035-EIP Interface module for EtherNet/IP with DIN rail housing

PS2020 Power supply 24V / 2.5A

EC2471-3/OE Encoder cable, 3 m



C5405/VAC/1/CF16  
C5405/VAC/1/KF16

### Sensor mounting adapter

#### MA5400-10

Sensor mounting adapter for all interferoMETER sensors:

(exception IMP-DS1, IMP-TH70)

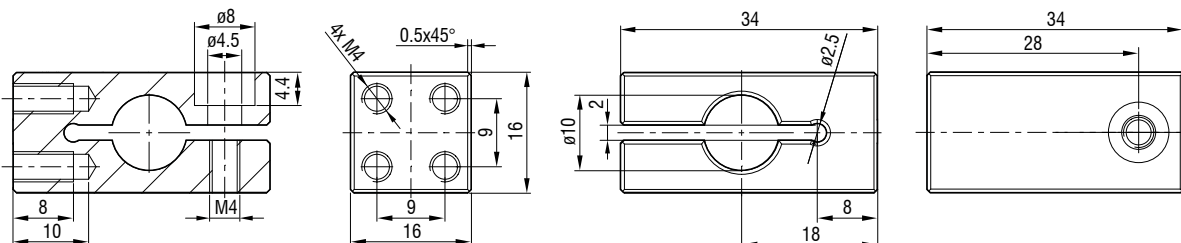

#### MA5400-20

Sensor mounting adapter for IMP-TH70 sensors:

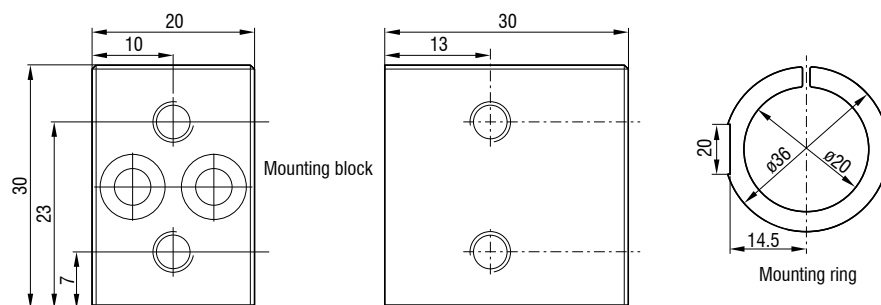

#### MA2402-4

Sensor mounting adapter for IMP-DS1 sensors

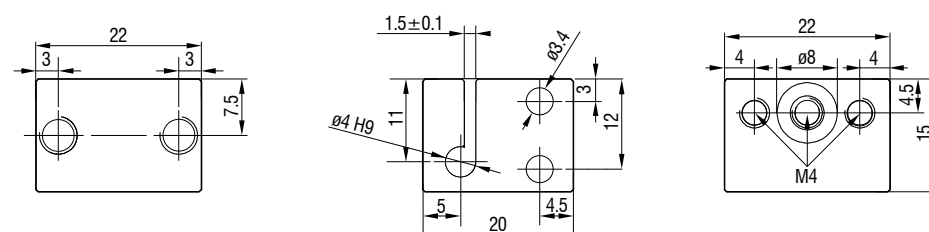



### Adjustable mounting adapter

The adjustable JMA mounting adapter simplifies the alignment and fine adjustment of interferometric sensors. The sensors and adapters can be integrated into the machine and aligned directly on site. This corrects, e.g., minor deviations caused by mounting and compensates for tilted measuring objects. With two-sided thickness measurements, the mounting adapter supports the fine alignment of the two measuring points.

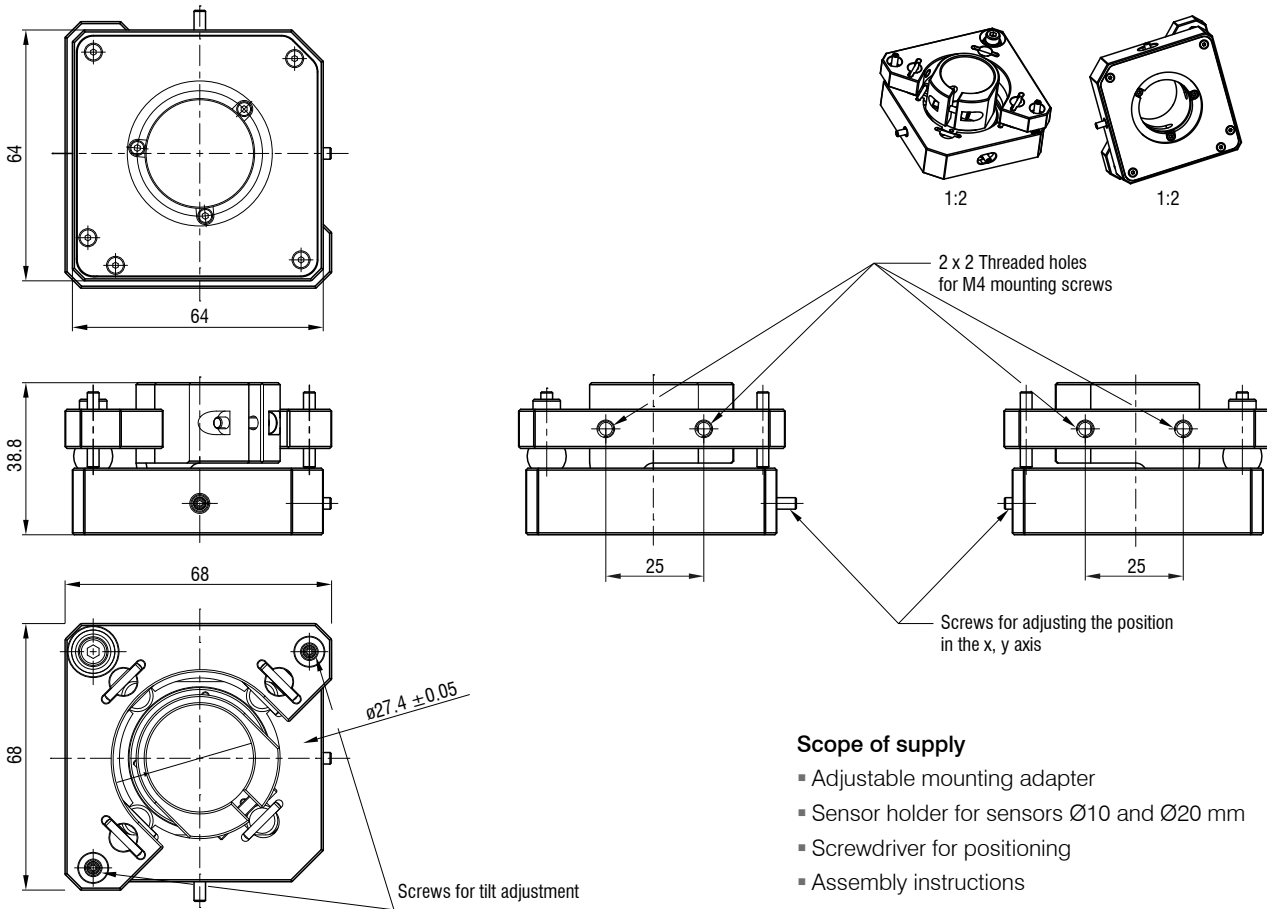

### Sensor holder

Sensor holder for JMA-10

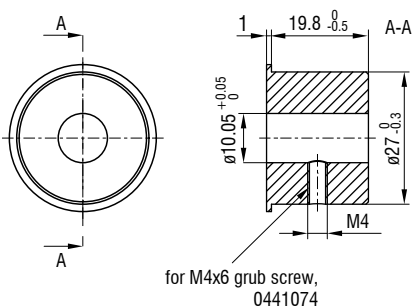

Sensor holder for JMA-20

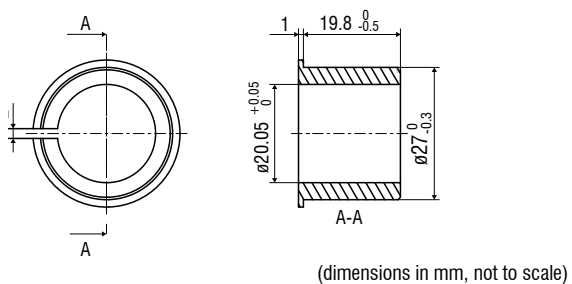

## Sensors and Systems from Micro-Epsilon

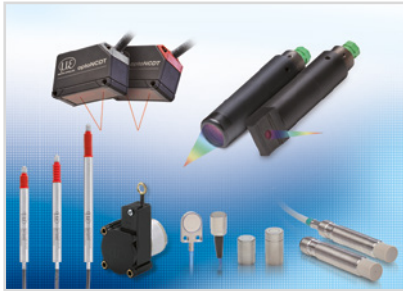

Sensors and systems for displacement, position and dimension



Sensors and measurement devices for non-contact temperature measurement



Measuring and inspection systems for quality assurance



Optical micrometers, fiber optics, measuring and test amplifiers



Color recognition sensors, LED Analyzers and inline color spectrometers



3D measurement technology for dimensional testing and surface inspection