



More Precision

capa**NCDT** // Capacitive sensors for displacement, distance & gap



Cylindrical standard sensors (socket)

capaNCDT CSx /CS-x



Model		CS005	CS02	CS08
Measuring range	Reduced	0.025 mm	0.1 mm	0.4 mm
	Nominal	0.05 mm	0.2 mm	0.8 mm
	Extended	0.1 mm	0.4 mm	1.6 mm
Resolution ^[1]	Static	0.015 nm	0.06 nm	0.24 nm
	Dynamic	1 nm	4 nm	16 nm
Linearity ^[2]		< ±0.2 μm	< ±0.4 μm	< ±0.24 μm
Replaceability ^[3]		< ±0.5 % FSO	< ±0.3 % FSO	< ±0.3 % FSO
Temperature stability ^[4]		-0.01 μm / K	-0.01 μm / K	-0.03 μm / K
Recommended target size (flat) ^[5]		Ø 3 mm	Ø 5 mm	Ø 9 mm
Active measuring area		Ø 1.3 mm	Ø 2.6 mm	Ø 4.9 mm
Connection ^[6]		Plug connection via triaxial socket (type C)		
Temperature range	Storage	-50 ... 200 °C		
	Operation	-50 ... 200 °C		
Shock (DIN EN 60068-2-27)		30g / 5 ms in XY axis, 1000 shocks each		
Vibration (DIN EN 60068-2-6)		20 g / 58 ... 2000 Hz in XY axis, 10 cycles each		
Protection class (DIN EN 60529)		IP40		
Material		NiFe (magn.)		
Weight		approx. 2 g	approx. 2 g	approx. 7 g
Mounting		Circumferential clamping		
Recommended mounting position ^[7]		3 mm		
Compatibility		Compatible with all capacitive controllers from Micro-Epsilon Sensors can be replaced as required without recalibration (see replacement accuracy)		

^[1] RMS noise referred to the end of the measuring range and to the nominal measuring range using the standard cable CCm (1.4 m); valid for operation with the DT6530: static 2 Hz, dynamic 8.5 kHz

^[2] Typical linearity that must be added to the controller linearity; applies to standard cable tuning CCm (1.4 m)

^[3] FSO = Full Scale Output | The value corresponds to the slope error that occurs when a sensor is replaced without recalibration

^[4] In recommended mounting position; from a temperature of +150 °C: non-linear signal drift

^[5] In relation to the nominal measuring range

^[6] For suitable sensor cables, please refer to Connections

^[7] From the sensor front face (measuring surface), opposite to the measuring direction

Mounting the cylindrical sensors CSx and CS-x

CSx / CS-x cylindrical sensors can be installed either protruding (with the sensor extending beyond the mounting bracket) or flush with the mounting bracket. The sensor is mounted either by point clamping using a plastic set screw or by circumferential clamping using a collet. When using circumferential clamps, please note that the surrounding material may cause heat buildup. CS-x series sensors with measuring ranges of ≤ 2 mm have a mechanically defined clamping point (slightly wider housing).

The technical specifications always refer to circumferential clamping at the recommended mounting position.

Recommended mounting of CSx sensors



With set screw

With circumferential clamping



Model		CS-0,25/C	CS-0,5/C	CS-1/B	CS-2/B	CS-3/B	CS-5/B	CS-10/B
Measuring range	Reduced	0.125 mm	0.25 mm	0.5 mm	1 mm	1.5 mm	2.5 mm	5 mm
	Nominal	0.25 mm	0.5 mm	1 mm	2 mm	3 mm	5 mm	10 mm
	Extended	0.5 mm	1 mm	2 mm	4 mm	6 mm	10 mm	20 mm
Resolution ^[1]	Static	0.075 nm	0.15 nm	0.3 nm	0.6 nm	0.9 nm	1.5 nm	3 nm
	Dynamic	5 nm	10 nm	20 nm	40 nm	60 nm	100 nm	200 nm
Linearity ^[2]		< ±0.125 μm	< ±0.15 μm	< ±1 μm	< ±0.4 μm	< ±0.6 μm	< ±1 μm	< ±15 μm
Replaceability ^[3]		< ±0.5 % FSO	< ±0.3 % FSO	< ±0.2 % FSO	< ±0.2 % FSO	< ±0.2 % FSO	< ±0.2 % FSO	< ±0.2 % FSO
Temperature stability ^[4]		-0.015 μm/K	-0.025 μm/K	-0.035 μm/K	-0.13 μm/K	-0.3 μm/K	-0.35 μm/K	-0.5 μm/K
Recommended target size (flat) ^[5]		Ø 5 mm	Ø 7 mm	Ø 9 mm	Ø 17 mm	Ø 27 mm	Ø 37 mm	Ø 57 mm
Active measuring area		Ø 2.9 mm	Ø 3.9 mm	Ø 5.5 mm	Ø 7.9 mm	Ø 9.6 mm	Ø 12.5 mm	Ø 17.8 mm
Connection ^[6]		Plug connection via triaxial socket (type C)			Plug connection via triaxial socket (type B)			
Temperature range	Storage	-50 ... 200 °C						
	Operation	-50 ... 200 °C						
Shock (DIN EN 60068-2-27)		50 g / 5 ms in 6 directions, 1000 shocks each						
Vibration (DIN EN 60068-2-6)		30 g / 10 ... 2000 Hz in 3 axes 2.5 mm, 10 cycles each						
Protection class (DIN EN 60529)		IP40						
Material		NiFe (magn.)			1.4404 (non-magn.)			
Weight		approx. 1.8 g	approx. 3.6 g	approx. 7.7 g	approx. 45.6 g	approx. 64.2 g	approx. 91.3 g	approx. 179.1 g
Mounting		Circumferential clamping						
Recommended mounting position		at the defined clamping range (marking on the sensor)				on the mandrel (Ø 20 mm); 7.5 mm behind the sensor face		
Compatibility		Compatible with all capacitive controllers from Micro-Epsilon Sensors can be replaced as required without recalibration (see replacement accuracy)						

^[1] RMS noise referred to the end of the measuring range and to the nominal measuring range using the standard cable CCm (1.4 m); valid for operation with the DT6530: static 2 Hz, dynamic 8.5 kHz
^[2] Typical linearity that must be added to the controller linearity; applies to standard cable tuning CCm (1.4 m)
^[3] FSO = Full Scale Output | The value corresponds to the slope error that occurs when a sensor is replaced without recalibration
^[4] In recommended mounting position; from a temperature of +150 °C: non-linear signal drift
^[5] In relation to the nominal measuring range
^[6] For suitable sensor cables, please refer to Connections

Recommended mounting of CS-x sensors

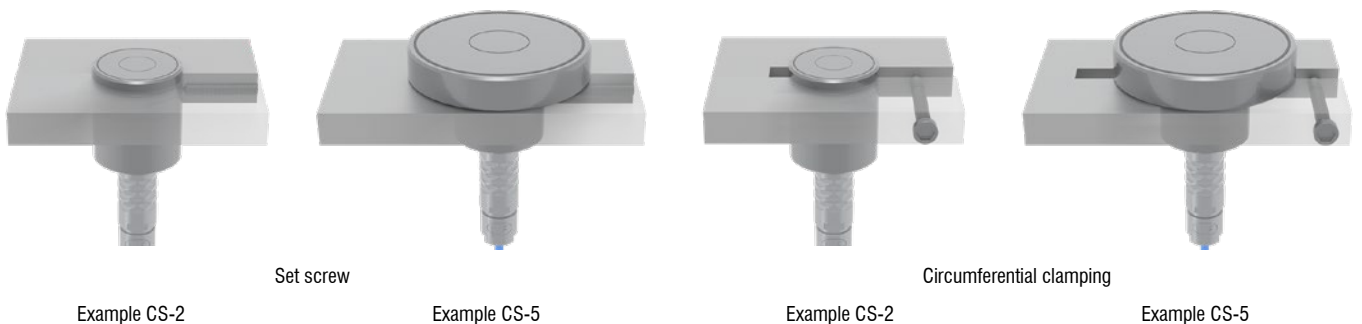

Dimensions

capaNCDT CSx /CS-x

CS005

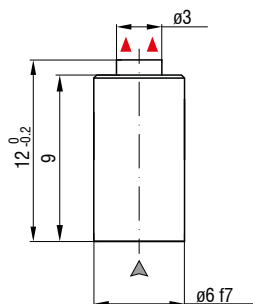

CS02

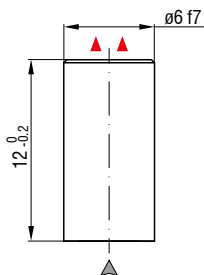

CS08

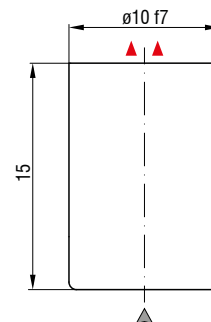

CS-0,25/C

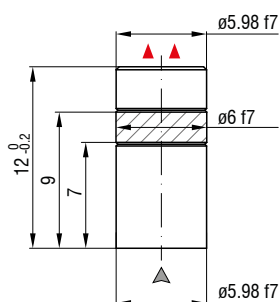

CS-0,5/C

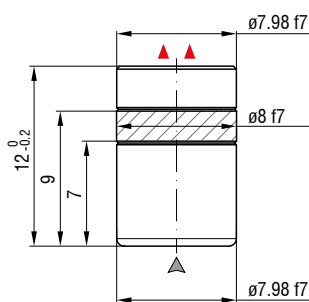

CS-1/B

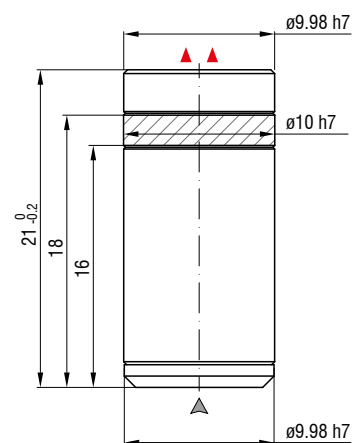

CS-2/B

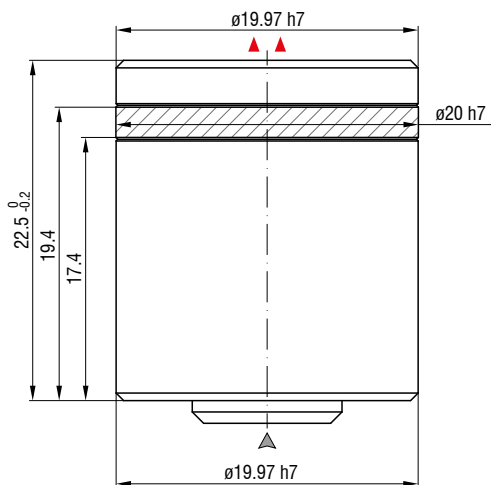

CS-3/B

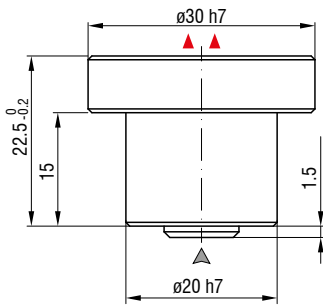

CS-5/B

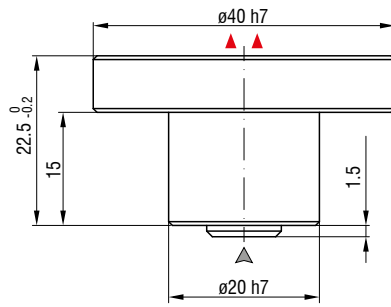

CS-10/B

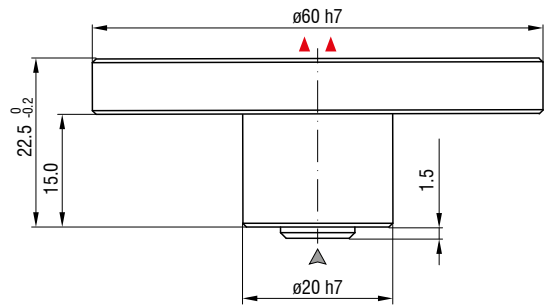

▲ ▲ Measurement direction

▲ Connector side

(dimensions in mm, not to scale)

Connections and combinations

capaNCDT

Controller



DT6100



DT6200



DT6500

Sensor cable



Type: CCg

Robust triaxial cable for industrial applications
 Cable diameter: 3.1 mm (± 0.1 mm)
 Minimum bending radius: static approx. 10 mm /
 dynamic approx. 30 mm
 Temperature resistance: -20 ... +85 °C (permanent) /
 -20 ... +100 °C (limited to 10,000 h)
 Standard length: 2 m (optional lengths see p. 41)

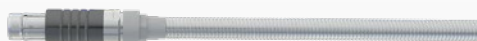

Type CCg/PT

Crush-resistant triaxial cable with protective metal tubing
 Cable diameter: 6 mm (± 0.15 mm)
 Minimum bending radius: static approx. 20 mm /
 dynamic approx. 30 mm
 Temperature resistance: -20 °C ... +85 °C (permanent) /
 -20 ... +100 °C (limited to 10,000 h)
 Standard length: 2 m (optional lengths see p. 41)

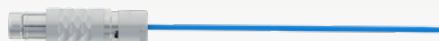

Type CCm

Low-outgassing triaxial cable for UHV and cleanroom
 Cable diameter: 2.1 mm (± 0.1 mm)
 Minimum bending radius: static approx. 7 mm /
 dynamic approx. 25 mm
 Temperature resistance: up to -100 ... 200 °C
 Standard length: 1.4 m (optional lengths see p. 41)



Type CCo

Low-outgassing triaxial cable for high temperatures
 Cable diameter: 3.1 mm (± 0.1 mm)
 Minimum bending radius: static approx. 10 mm /
 dynamic approx. 30 mm
 Temperature resistance: -20 ... +200 °C
 Standard length: 2 m (optional lengths see p. 41)

Sensors with integrated cable use the cable types CCM and CCg

Type CCM

Low-outgassing triaxial cable for UHV and cleanroom
 Cable diameter: 2.1 mm (± 0.1 mm)
 Minimum bending radius: static approx. 15 mm /
 dynamic approx. 30 mm
 Temperature resistance: up to 200 °C
 Standard length: 1.4 m (optional lengths see p. 41)

Type CCg

Robust triaxial cable for industrial applications
 Cable diameter: 3.1 mm (± 0.1 mm)
 Minimum bending radius: static approx. 10 mm /
 dynamic approx. 30 mm
 Temperature resistance: -20 °C ... +85 °C (permanent) /
 -20 ... +100 °C (limited to 10,000 h)
 Standard length: 2 m (optional lengths see p. 41)

Plug connector



Type B connector



Type B / 90 connector



Type B / IP connector



Type C connector



Type C / 90 connector



Type E connector

Sensors with socket



CS-x, CSE and CSE/Mx models
with a measuring range from 1 mm

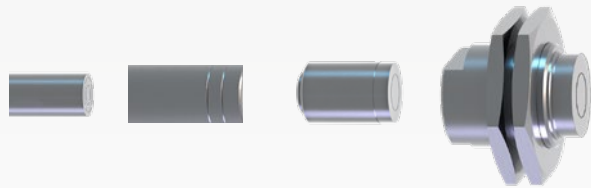

CS, CS-x, CSE and CSE/Mx models
with measuring range up to 1 mm



CSF flat sensors with socket

Sensors with integrated cable



Vacuum feedthroughs

Micro-Epsilon offers a variety of vacuum feedthroughs for the quick and easy integration of capacitive sensors in high-vacuum and ultra-high-vacuum environments. The feedthroughs are available as screw-in or weld-in versions, or with a large flange. All models are designed for sensors with a type B connector. Feedthroughs for sensors with connector types C and E are available upon request.

Vacuum feedthrough screwable

Art. no. 0323050

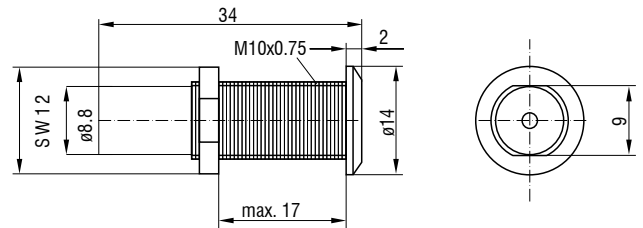

Maximum leak rate: 1×10^{-7} mbar-l-s⁻¹, compatible with type B connectors

Vacuum feedthrough weldable

Art. no. 0323346

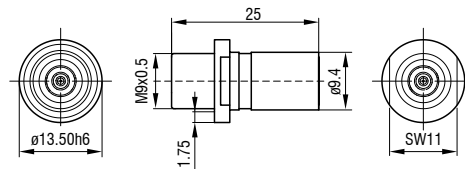

Maximum leak rate: 1×10^{-9} mbar-l-s⁻¹, compatible with type B connectors

Vacuum feedthrough with flange (CF16)

Art. no. 0323349

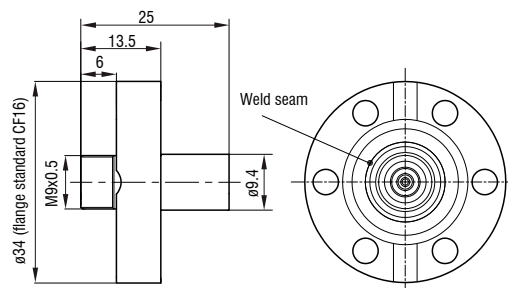

Maximum leak rate: 1×10^{-9} mbar-l-s⁻¹, compatible with type B connectors

Technical details

capaNCDT

Minimum diameter of the measuring object

The relative size of the target has effects on the linearity deviation. Ideally, the object being measured should be at least as large as the "Recommended target size" specified in the technical data, or at least as large as the sensor's diameter. In this case, the sensor's full measuring range can be used without the need for additional calibration. Measuring objects smaller than the sensor diameter require a special calibration. The smaller the size (ratio measurement electrode and measuring object), the lower the accuracy.

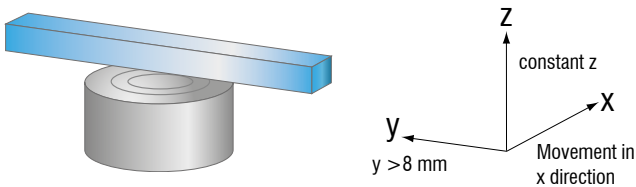
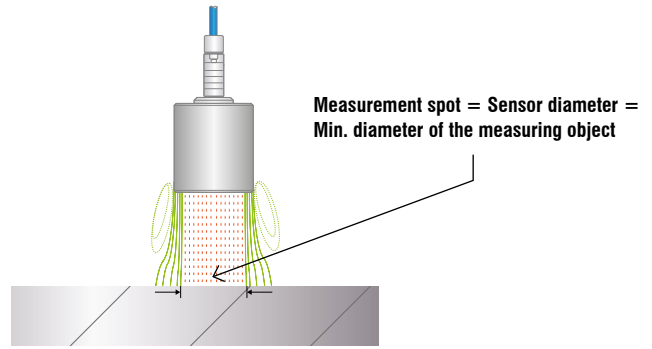

Measurement on narrow targets

The width of the object being measured affects the capacitive measurement signal. Simulations using a CS05 sensor (8 mm diameter) as an example show that even narrow objects can be measured reliably, provided they are sufficiently large and correctly positioned.

At a distance of 0.25 mm (mid of measuring range), even a centrally positioned object 5 mm wide produces a stable measurement signal. The larger the distance between the sensor and the measuring object, the larger the required minimum width.

The results show that the electric field does not extend beyond the entire diameter of the sensor. This makes it possible to take precise measurements even on narrow objects.

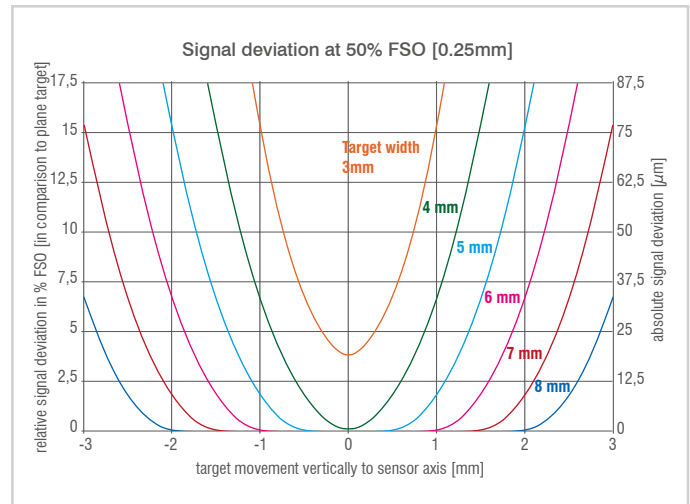

Conductivity of the measuring object

In order to achieve a linear output signal across the complete measuring range, certain requirements for the target or the counter electrode must be complied with. The impedance in the ideal plate capacitor can be shown in the equivalent circuit diagram by a capacitor and a resistor connected in parallel. For measurement against metals, the ohm part can be disregarded; the impedance is only determined by the capacitive part. Conversely, only the ohm part is considered for measurements against insulators.

In between, there is the large range of semiconductors. Most semiconductors can be measured very well as electrical conductors. The requirement is that the capacitive part of the total impedance is still significantly larger (>10x) than the ohmic part. This is almost always the case for silicon wafers irrespective of the endowment. Nevertheless, semiconductors with poor conductivity (e.g. GaAs) can also be measured as conductors under certain circumstances.

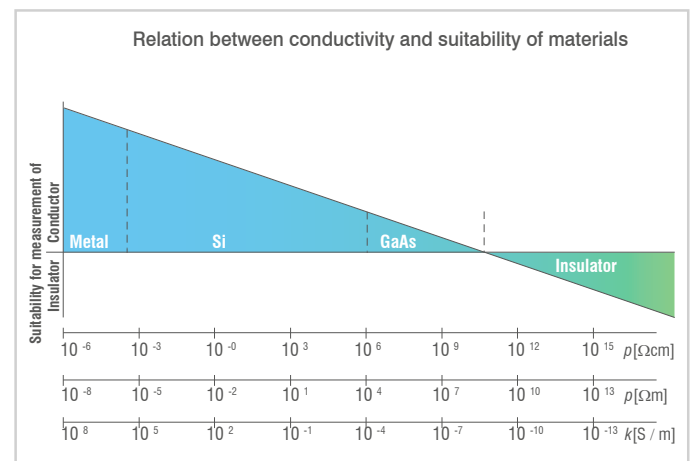

However, various adjustments are required for this, e.g. reduction of the operating frequency or a temporary, partial increase of the conductivity.

Minimum diameter of round measuring objects:

When measuring distances on curved surfaces such as when measuring wave patterns on rollers, measurement errors may occur. This is caused by the altered field line distribution and an enlarged effective measurement spot, which changes the measured capacitance. In practice, this results in a virtual zero point for the sensor, meaning that the measurement value of $0 \mu\text{m}$ is no longer

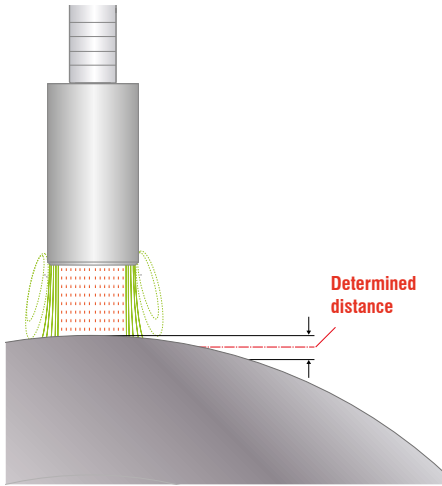

Example: For a sensor with a $200 \mu\text{m}$ measuring range and a roller with an outer diameter of 30 mm , an actual gap of $20 \mu\text{m}$ results in a measured value that is approximately 5 % higher. This corresponds to approx. $10 \mu\text{m}$ of the measuring range.

achieved. Since capacitive sensors integrate over their entire measuring surface, the virtual mean measurement plane lies behind the actual generatrix of the cylindrical target object. As this effect is predictable, corresponding correction curves can be stored in the controller.

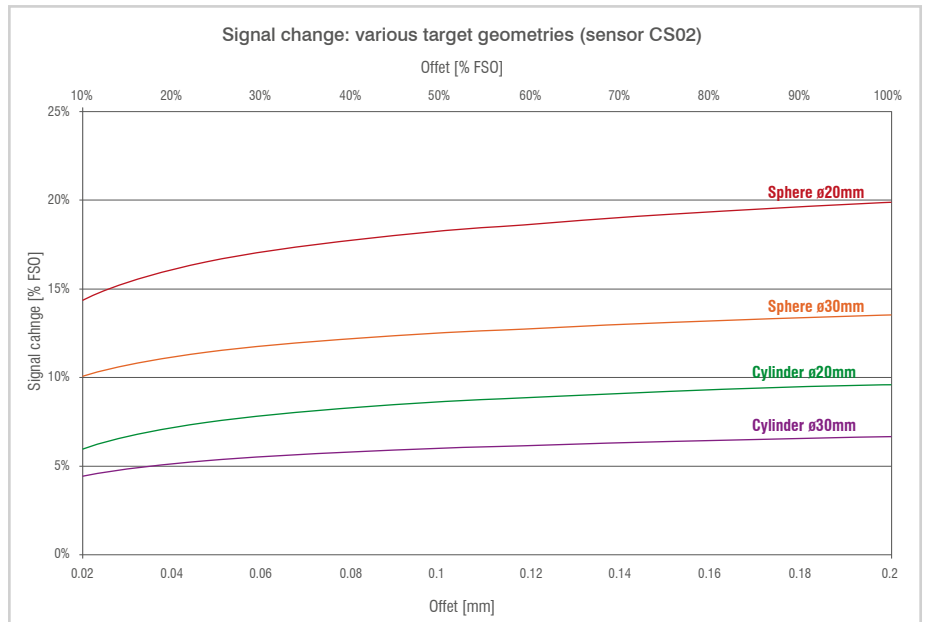

Inclination:

If the capacitive sensor or the measuring object is tilted, an error is likely to occur, as the geometric conditions of the field relative to the object being measured change. In fact, the average distance of the sensor remains constant; however, the edge areas move closer or further away from the target. The following figure illustrates this effect using the CS02 sensor as an example, with a maximum tilt angle of

1° at various sensor distances. At a 10 % offset along the sensor axis, contact between the sensor housing and the measuring object occurs at 0.38° ; at a 20 % offset, contact occurs at 0.76° . The simulation can be performed for all sensors and installation conditions; tilt angles around a decentralized tilt point can also be calculated.

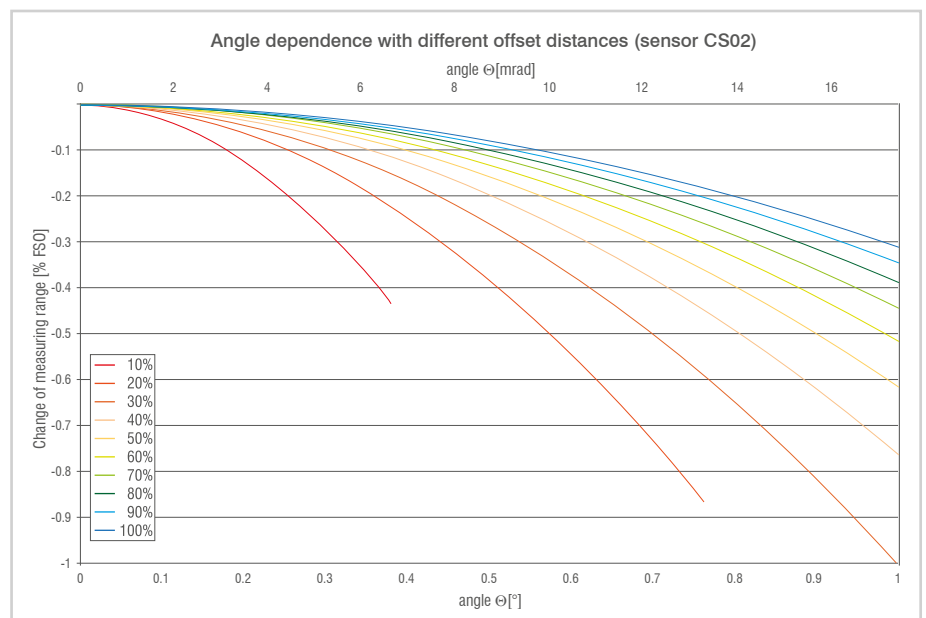
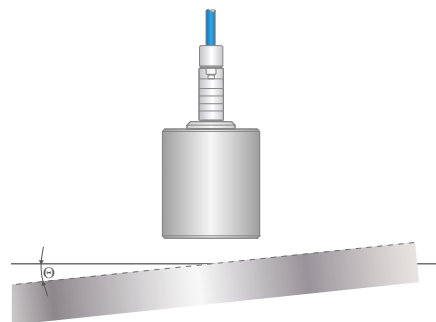

Sensors and Systems from Micro-Epsilon



Sensors and systems for displacement, distance and position



Sensors and measurement devices for non-contact temperature measurement

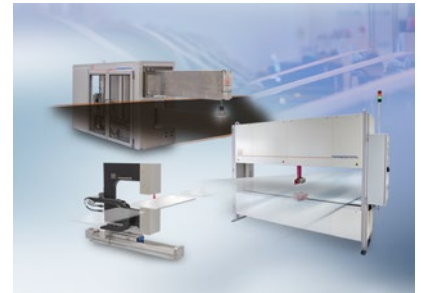

Measuring and inspection systems for metal strips, plastics and rubber



Optical micrometers and fiber optics, measuring and test amplifiers



Color recognition sensors, LED analyzers and inline color spectrometers

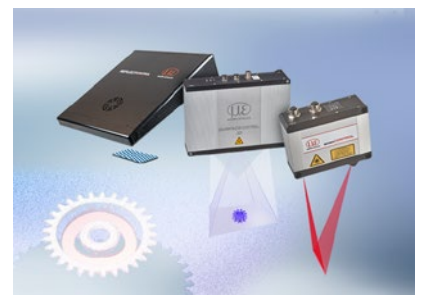

3D measurement technology for dimensional testing and surface inspection