











# More Precision

**optoNCDT** // Laser displacement sensors (triangulation)



# Smart laser sensors for precise measurements optoNCDT 1900

designed for advanced  
**AUTOMATION**

-  For common surfaces
-  Measuring rate up to 10 kHz
-  **INTERFACE** Analog (U/I) / RS422 / PROFINET / EtherNet/IP / EtherCAT
-  **ASc** Advanced Surface Compensation
-  Repeatability  $<0.1 \mu\text{m}$
-  Ideal for series and OEM applications
-  Highest immunity to ambient light
-  High resistance to shocks and vibrations



## Next-generation laser sensors

The optoNCDT 1900 laser sensors are used for dynamic displacement, distance and position measurements and offer a unique combination of performance, design and integration capability. The integrated high-performance controller enables fast and highly precise processing and output of measurement values.

These innovative sensors are used whenever maximum precision is combined with the latest technology, e.g., in sophisticated automation, automotive production, 3D printing and coordinate measuring machines.

## Advanced Surface Compensation – The intelligent exposure control for demanding surfaces

The optoNCDT 1900 laser sensors are equipped with an intelligent surface control feature. Innovative algorithms enable stable measurement results even on demanding surfaces where changing reflections occur. Furthermore, these new algorithms compensate for ambient light up to 50,000 lux. Therefore, these are the sensors with the highest resistance to ambient light in their class and can even be used in strongly illuminated environments.



**Advanced Surface Compensation**  
With rapidly changing surfaces, the exposure control enables reliable measurement results.

## Industrial Ethernet for easy integration



The latest optoNCDT 1900 laser triangulation sensors are also available with integrated Industrial Ethernet interface. Depending on the model, you can integrate the full sensor performance into your PLC directly via EtherCAT, EtherNet/IP or PROFINET without any additional interface module. You benefit from real-time data without time delay as well as reduced installation and wiring effort.

The sensor parameters can be set directly via Industrial Ethernet or still via web interface. For high speed measurements, the sensor offers an Oversampling feature which allows, depending on the fieldbus, measurement data to be detected or transmitted eight times faster than the bus cycles.

EtherCAT®

EtherNet/IP®

PROFINET®

Model	Technology	Measuring range	Repeatability	Linearity
optoNCDT 1900		2 - 500 mm	0.1 $\mu\text{m}$	from 0.02 %
optoNCDT 1900LL		2 - 50 mm	0.1 $\mu\text{m}$	from 0.02 %

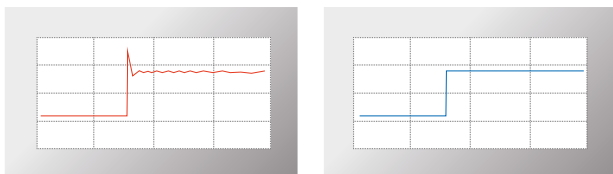
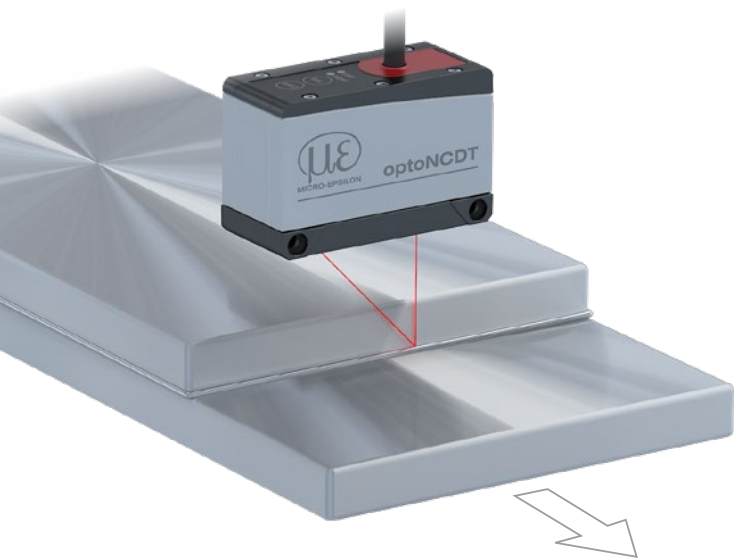

The two-step measurement value averaging enables smooth signal courses when measuring edges (right). Otherwise, interfering signals occur (left).

#### Highest stability based on intelligent signal optimization

For the first time, a two-step measurement value averaging feature is available to optimize the signal. This enables a smooth signal at edges and steps. Especially for high speed measurements of moving parts, measurement averaging enables a precise signal course.

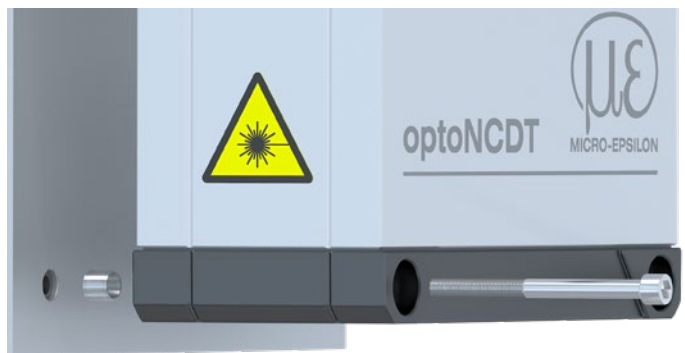

#### Patented installation

Easy mounting and high repeatability when replacing the sensor

#### Simple mounting and initial operation

Mounting the sensor using fitting sleeves automatically aligns the sensor in the correct position. This enables both easy sensor replacement and even higher precision in solving measurement tasks. Thanks to its small dimensions, the laser sensor can also be integrated in confined spaces.

### Application examples

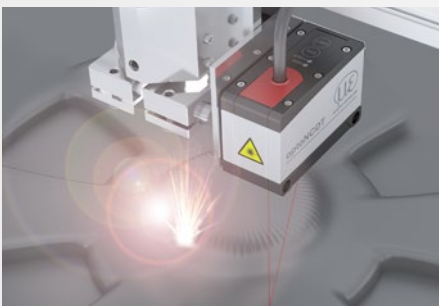

Distance measurement of print heads

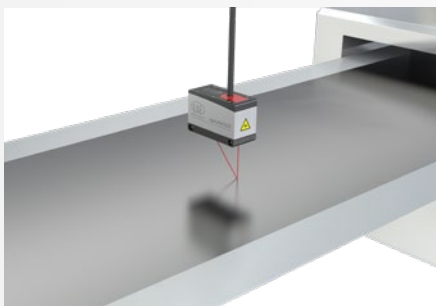

Thickness measurement of electrode film

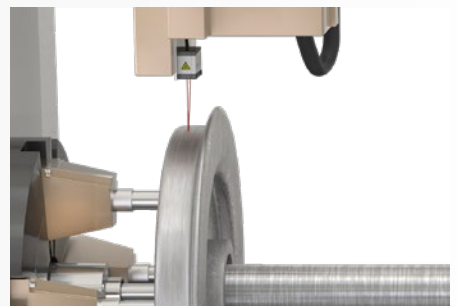

Wear inspection of wheel tires

# Technical data

## optoNCDT 1900

### optoNCDT 1900 (General technical data)

Model		ILD1900-xx
Measuring rate <sup>[1]</sup>	7 adjustable stages: 10 kHz / 8 kHz / 4 kHz / 2 kHz / 1 kHz / 500 Hz / 250 Hz	
Temperature stability <sup>[2]</sup>	±0.005 % FSO / K	
Light source	Semiconductor laser ≤ 1 mW, 670 nm (red) with laser class 2	
Laser class	Class 2 in accordance with IEC 60825-1: 2014 (Class 3 available on request)	
Supply voltage	11 ... 30 VDC	
Power consumption	< 3 W (24 V)	
Signal input	1 x HTL/TTL laser on/off; 1 x HTL/TTL multi-function input: trigger in, slave in, zero setting, mastering, teach-in; 1 x RS422 synchronization input: trigger in, sync in, master/slave, master/slave alternating	
Digital interface <sup>[3]</sup>	RS422 (18 bit) / EtherCAT / PROFINET / EtherNet/IP	
Analog output	4 ... 20 mA / 0 ... 5 V / 0 ... 10 V (16 bit, freely scalable within the measuring range)	
Switching output	2x switching outputs (error & limit value): npn, pnp, push pull	
Connection	integrated cable 3 m, open ends, min. bending radius 30 mm (fixed installation); or integrated pigtail 0.3 m with 17-pin M12 plug; optional extension to 3 m / 6 m / 9 m / 15 m possible (suitable connection cable see Accessories)	
Temperature range	Storage	-20 ... +70 °C (non-condensing)
	Operation	0 ... +50 °C (non-condensing)
Shock (DIN EN 60068-2-27)	15 g / 6 ms in 3 axes	
Vibration (DIN EN 60068-2-6)	30 g / 20 ... 500 Hz	
Protection class (DIN EN 60529)	IP67	
Material	Aluminum housing	
Weight	approx. 185 g (incl. pigtail), approx. 300 g (incl. cable)	
Control and indicator elements <sup>[4]</sup>	Select & function keys: interface selections, mastering (zero), teach, presets, quality slider, frequency selection, factory settings; web interface for setup: application-specific presets, peak selection, video signal, freely selectable averaging possibilities, data reduction, setup management; 2 x color LEDs for power / status	

<sup>[1]</sup> Factory setting: measuring rate 4 kHz, median 9; modifying the factory setting requires the IF2001/USB converter (see accessories)

<sup>[2]</sup> Related to digital output in the mid of the measuring range; the specified value is only achieved by mounting on a metallic sensor holder. Good heat dissipation from the sensor to the holder must be ensured; value is valid in a range from 20 °C to 50 °C

<sup>[3]</sup> EtherCAT, PROFINET and EtherNet/IP require connection via interface module (see accessories)

<sup>[4]</sup> Access to web interface requires connection to PC via IF2001/USB (see accessories)

# Technical data

## optoNCDT 1900



### Laser point - optoNCDT 1900 / Measuring ranges 2 - 25

Model		ILD1900-2	ILD1900-6	ILD1900-10	ILD1900-25
Measuring range		2 mm	6 mm	10 mm	25 mm
Start of measuring range		15 mm	17 mm	20 mm	25 mm
Mid of measuring range		16 mm	20 mm	25 mm	37.5 mm
End of measuring range		17 mm	23 mm	30 mm	50 mm
Linearity <sup>[1]</sup>		< ±1 µm	< ±1.8 µm	< ±2 µm	< ±5 µm
		< ±0.05 % FSO	< ±0.03 % FSO	< ±0.02 % FSO	< ±0.02 % FSO
Repeatability <sup>[2]</sup>		< 0.1 µm	< 0.25 µm	< 0.4 µm	< 0.8 µm
Light spot diameter <sup>[3]</sup>	SMR	60 x 75 µm	85 x 105 µm	115 x 150 µm	200 x 265 µm
	MMR	55 x 65 µm	57 x 60 µm	60 x 65 µm	70 x 75 µm
	EMR	65 x 75 µm	105 x 120 µm	120 x 140 µm	220 x 260 µm
	smallest Ø	55 x 65 µm with 16 mm	57 x 60 µm with 20 mm	60 x 65 µm with 25 mm	65 x 70 µm with 35 mm
Permissible ambient light		50,000 lx			

<sup>[1]</sup> FSO = Full Scale Output; the specified data apply to white, diffuse reflecting surfaces (Micro-Epsilon reference ceramic for ILD sensors)

<sup>[2]</sup> Typical value with measurements at 4 kHz and median 9

<sup>[3]</sup> ±10 %; SMR = Start of measuring range; MMR = Mid of measuring range; EMR = End of measuring range

Light spot diameter determined using a point-shaped laser with Gaussian fit (full 1/e<sup>2</sup> width); for ILD1900-2: determined with emulated 90/10 knife-edge method



### Laser point - optoNCDT 1900 / Measuring ranges 50 - 500

Model		ILD1900-50	ILD1900-100	ILD1900-200	ILD1900-500
Measuring range		50 mm	100 mm	200 mm	500 mm
Start of measuring range		40 mm	50 mm	60 mm	100 mm
Mid of measuring range		65 mm	100 mm	160 mm	350 mm
End of measuring range		90 mm	150 mm	260 mm	600 mm
Linearity <sup>[1]</sup>		< ±10 µm	< ±30 µm	< ±100 µm	< ±400 µm
		< ±0.02 % FSO	< ±0.03 % FSO	< ±0.05 % FSO	< ±0.08 % FSO
Repeatability <sup>[2]</sup>		< 1.6 µm	< 4 µm	< 8 µm	< 20 ... 40 µm
Light spot diameter <sup>[3]</sup>	SMR	220 x 300 µm	310 x 460 µm	950 x 1200 µm	950 x 1200 µm
	MMR	95 x 110 µm	140 x 170 µm		
	EMR	260 x 300 µm	380 x 410 µm		
	smallest Ø	85 x 90 µm with 55 mm	120 x 125 µm with 75 mm	-	-
Permissible ambient light		50,000 lx	30,000 lx	10,000 lx	10,000 lx

<sup>[1]</sup> FSO = Full Scale Output; the specified data apply to white, diffuse reflecting surfaces (Micro-Epsilon reference ceramic for ILD sensors)

<sup>[2]</sup> Typical value with measurements at 4 kHz and median 9

<sup>[3]</sup> ±10 %; SMR = Start of measuring range; MMR = Mid of measuring range; EMR = End of measuring range

Light spot diameter determined using a point-shaped laser with Gaussian fit (full 1/e<sup>2</sup> width); for ILD1900-2: determined with emulated 90/10 knife-edge method

# Dimensions

## optoNCDT 1900

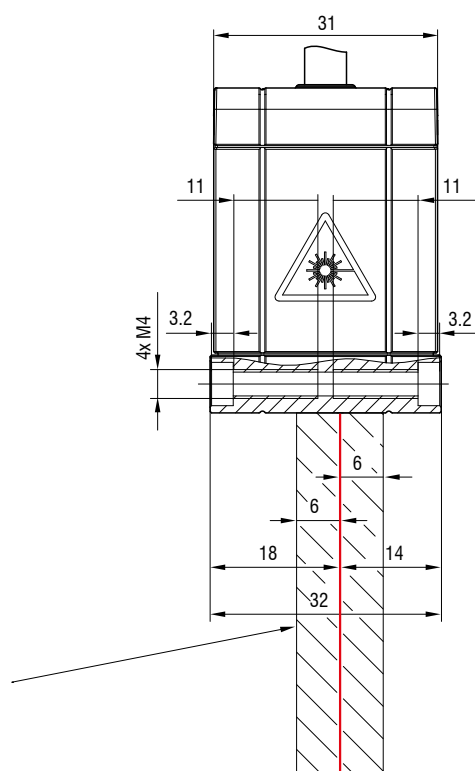
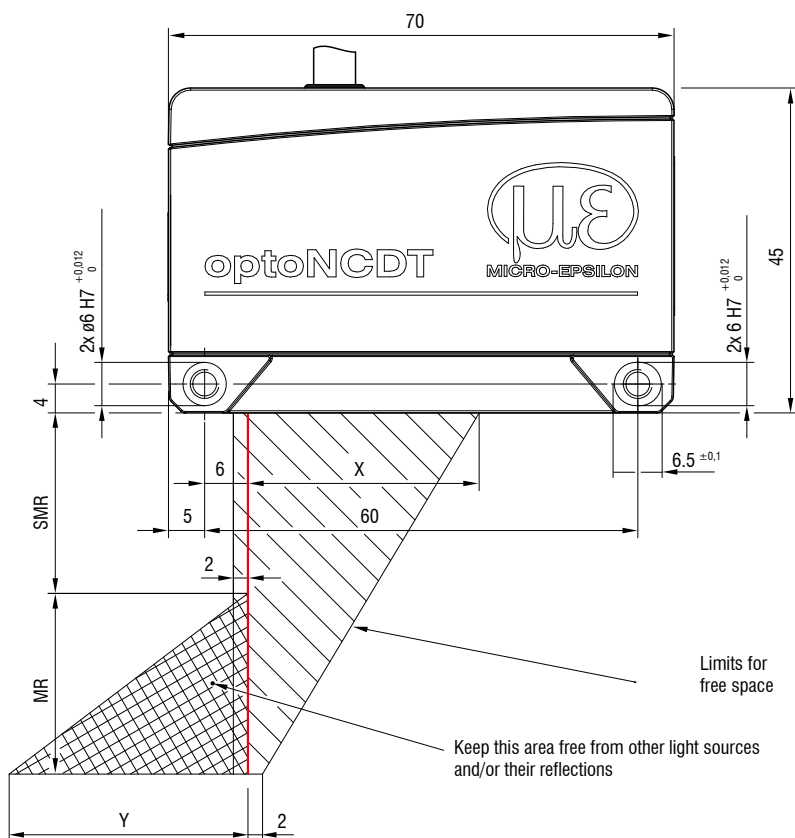

MR	SMR	X	Y
2	15	23	3
6	17	27	9
10	20	33	14
25	25	33	33
50	40	36	45
100	50	37	75
200	60	39	130
500	100	43	215

(Dimensions in mm, not to scale)

MR = measuring range; SMR = start of measuring range

MMR = mid of measuring range; EMR = end of measuring range

### Connector (sensor side)

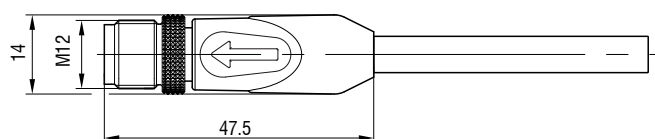

**Installation options**

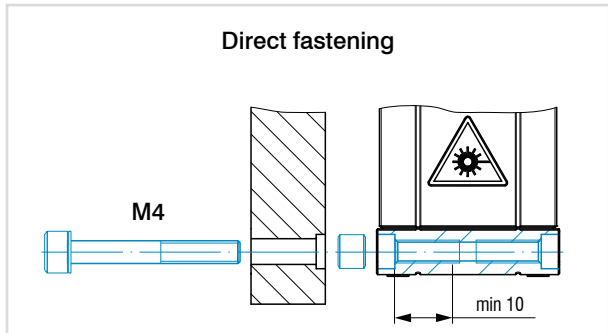
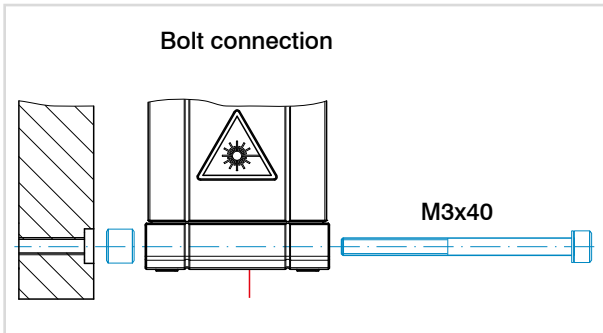

**Accessories for optoNCDT 1900/1910**

**Power supply unit**

PS2020 (power supply 24 V / 2.5 A, input 100 - 240 VAC, output 24 VDC / 2.5 A, mounting onto symmetrical standard rail 35 mm x 7.5 mm, DIN 50022)

**Protective film**

Transparent protective film 52 x 15 mm for ILD1900

**Protective housings**

with air purge and cooling, see page 60

**Scope of supply**

- 1 Sensor ILD1900/1910
- 1 Assembly instructions
- 1 Calibration protocol
- Accessories (2 pc. centering sleeves, 2 pc. M3 x 40)

**Article designation**



ILD1900-	6	LL	CL3B	EtherCAT
				<b>Interface</b> No indication: RS422, current, voltage (standard) integrated fieldbus: EtherCAT, EtherNet/IP, PROFINET
				<b>Laser class</b> No indication: class 2 (standard) 3B: on request 3R: on request
				<b>Laser type</b> No indication: Red laser point (standard) LL: Laser Line
<b>Measuring range</b> in mm				
<b>Series</b> ILD1900: Laser displacement sensor for Advanced Automation				

# Connection possibilities

## optoNCDT 1900







### Connection possibilities for sensors with integrated cables

Cable diameter: 5.80 ±0.2 mm  
 Drag chain: yes  
 Robot: no  
 Temperature range: -25 ... 80 °C (moving)  
 -40 ... 80 °C (not moving)  
 Bending radius: > 30 mm (fixed installation)  
 > 75 mm (dynamic)

Sensor	Cables	Type	Connection possibilities and accessories
LD1900-xx ILD1900-xxLL ILD1910-xx	Integrated cable length 3 m	Open ends	<p><b>Supply voltage connection</b> Power supply unit PS2020</p>  <p><b>Interface module of RS422 to USB</b> IF2001/USB IC2001/USB</p>  <p><b>Interface module for Industrial Ethernet connection</b> IF2035-PROFINET IF2035-EIP IF2035-EtherCAT</p> 



### Drag-chain suitable connection cables for sensors with pigtail

Cable diameter: 6.7 ±0.2 mm  
 Drag chain: yes  
 Robot: no  
 Temperature range: -25 ... 80 °C (moving) (up to +105 °C for max. 3000 hrs)  
 -40 ... 80 °C (not moving)  
 Bending radius: > 34 mm (fixed installation)  
 > 67 mm (dynamic)  
 > 81 mm (drag chain)

Sensor	Cables	Type	Connection possibilities and accessories
ILD1900-xx ILD1900-xxLL ILD1910-xx	<b>Extension cable pigtail</b> Length 3 m / 6 m / 9 m / 15 m <i>Art. no. Designation</i> 29011218 PC1900-3/OE 29011219 PC1900-6/OE 29011220 PC1900-9/OE 29011221 PC1900-15/OE	Open ends	<p><b>Connection supply voltage</b> PS2020</p>  <p><b>Interface module of RS422 to USB</b> IF2001/USB IC2001/USB</p>  <p><b>Interface module for Industrial Ethernet connection</b> IF2035-PROFINET IF2035-EIP IF2035-EtherCAT</p> 
	<b>Adapter cable for PC interface card</b> Length 3 m / 6 m / 9 m / 15 m <i>Art. no. Designation</i> 29011316 PC1900-3/IF2008 PCIE 29011317 PC1900-6/IF2008 PCIE 29011318 PC1900-9/IF2008 PCIE 29011319 PC1900-15/IF2008 PCIE	Sub-D	<p><b>Interface card for synchronous data acquisition</b> IF2008PCIE / IF2008E</p>  <p><b>4-fold interface module from RS422 to USB</b> IF2004/USB</p> 
	<b>Adapter cable for sensor calculation</b> Length 3 m / 6 m / 9 m / 15 m <i>Art. no. Designation</i> 29011320 PC1900-3/C-Box 29011321 PC1900-6/C-Box 29011322 PC1900-9/C-Box 29011323 PC1900-15/C-Box	Sub-D	<p><b>Controller for D/A conversion and evaluation of up to 2 sensor signals</b> Dual Processing Unit</p> 
	<b>Adapter cable for sensor calculation</b> Length 3 m <i>Art. no. Designation</i> 29011326 PCE1900-3/M12	M12	<p><b>Interface module for Ethernet connection of up to 8 sensors</b> IF2008/ETH</p> 

## Robot-suitable connection cables

Cable diameter:	approx. 7.3 mm
Drag chain:	no
Robot:	yes
Temperature range:	-40 ... 90 °C (moving) -50 ... 90 °C (not moving)
Bending radius:	> 37 mm (fixed installation) > 73 mm (dynamic)

Sensor	Cables	Type	Connection possibilities and accessories
LD1900-xx ILD1900-xxLL	<b>Extension cable pigtail</b> Length 3 m / 6 m / 9 m / 15 m <i>Art. no.      Designation</i> 29011404      PC1900R-3/OE 29011405      PC1900R-6/OE 29011406      PC1900R-9/OE 29011407      PC1900R-15/OE	Open ends	<b>Connection supply voltage</b> PS2020 
			<b>Interface module of RS422 to USB</b> IF2001/USB IC2001/USB 
ILD1910-xx			<b>Interface module for Industrial Ethernet connection</b> IF2035-PROFINET IF2035-EIP IF2035-EtherCAT 

## Connection cables for sensors with integrated Industrial Ethernet interface



Cable diameter:	7.5 ±0.2 mm
Drag chain:	yes
Robot:	no
Temperature range:	-40 ... 90 °C (moving) -50 ... 90 °C (not moving)
Bending radius:	> 38 mm (fixed installation) > 75 mm (dynamic)

Sensor	Cables	Type	Connection possibilities and accessories
ILD1900-xx-PROFINET* ILD1900-xxLL-PROFINET*	<b>Connection cables PoE, laser On/Off hardware</b> Length 3 m / 6 m / 9 m / 15 m <i>Art. no.      Designation</i> 29011332      PC1900-IE-3/OE-RJ45 29011333      PC1900-IE-6/OE-RJ45 29011334      PC1900-IE-9/OE-RJ45 29011444      PC1900-IE-15/OE-RJ45	Open ends & RJ45	<b>Signal / Supply PoE</b> optional: PoE Switch 
ILD1900-xx-EtherCAT ILD1900-xxLL-EtherCAT			
ILD1900-xx-EtherNet/IP ILD1900-xxLL-EtherNet/IP	<b>Connection cables PoE, laser On/Off Software</b> Length 3 m / 6 m / 9 m / 15 m <i>Art. no.      Designation</i> 29011338      PC1900-IE-3/RJ45 29011355      PC1900-IE-6/RJ45 29011356      PC1900-IE-9/RJ45 29011445      PC1900-IE-15/RJ45	RJ45	

\*PoE not possible with PROFINET





## Other cables

Cable diameter:	6.7 mm
Drag chain:	yes
Robot:	no
Temperature range:	-40 ... 80 °C
Bending radius:	> 27 mm (fixed installation) > 51 mm (dynamic)

Input	Cables	Type	Connection possibilities and accessories
2 x Sub-D (PC1900-x/ IF2008 PCIE)	<b>Adapter cable for the connection of two sensors per Sub-D connector</b> Length 0.1 m <i>Art. no.      Designation</i> 2901528      IF2008-Y-adapter cable 	Sub-D	<b>Interface card for synchronous data acquisition</b> IF2008PCle / IF2008E 
			<b>4-fold USB converter &amp; parameter setting</b> IF2004/USB 

# Protective housings for demanding environments

**optoNCDT**

SGH & SGHF models				SGHF-HT model
Protective housing Size S		Protective housing Size M		
SGH	SGHF	SGH	SGHF	
				
(140 x 140 x 71 mm)		(180 x 140 x 71 mm)		(260 x 180 x 154 mm)
Water-resistant housing protects the sensor from solvents and detergents.	Ideal with high ambient temperatures. The integrated air cooling of the housing offers optimum protection for the sensor.	Water-resistant housing protects the sensor from solvents and detergents.	Ideal with high ambient temperatures. The integrated air cooling of the housing offers optimum protection for the sensor.	Water-cooled protective housing with window and compressed-air connection for measurement tasks in ambient temperatures up to 200 °C. Maximum temperature of cooling water T(max) = 10 °C Minimum water flow rate Q(min) = 3 liters/min
Size S suitable for ILD1750-20BL ILD1750-200BL ILD2300-2 / -2LL / -2BL ILD2300-5 / -5BL ILD2300-10 / -10LL / -10BL ILD2300-20 / -20LL ILD2300-50 / -50LL ILD2300-100		Size M suitable for ILD1750-500BL ILD1750-750BL ILD2300-200 ILD2300-300 ILD2310-10 ILD2310-20 ILD2310-40		Suitable for ILD1750-500BL ILD1750-750BL ILD2300-200 ILD2300-300 ILD2310-10 ILD2310-20 ILD2310-40 ILD2310-50BL

Protective housing SGHF ILD1900

Compact protective housing which is simply attached to the sensor. The protective housing has an air purge for cleaning the protective windows. It also cools the sensor.
Suitable for ILD1900-6 / -6LL ILD1900-10 / -10LL ILD1900-25 / -25LL ILD1900-50 / -50LL ILD1900-100 ILD1900-200 ILD1900-500

## sensorTOOL

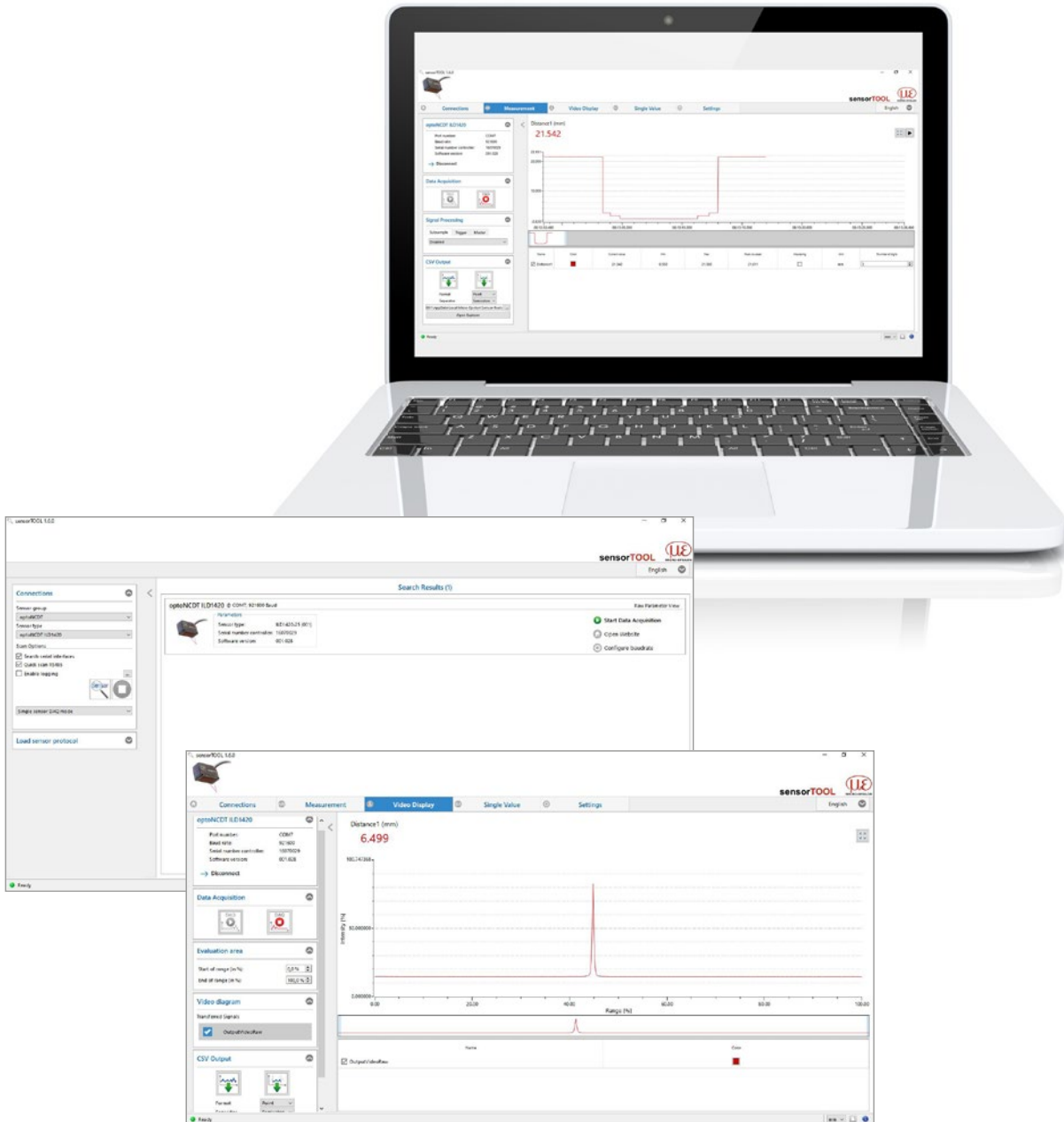
The Micro-Epsilon sensorTOOL is a powerful software that is used to operate one or more optoNCDT sensors. The sensorTOOL can be used to access the sensor connected to the PC, display its complete data stream and save it in a file (in Excel-compatible CSV format). The sensor is configured via its web interface.



### Free download

All software tools, drivers and documented driver DLL for easy integration of the sensors into existing or internally-generated software are available free of charge under [www.micro-epsilon.de/download](http://www.micro-epsilon.de/download)

## Sensors and Systems from Micro-Epsilon



Sensors and systems for displacement, distance and position



Sensors and measurement devices for non-contact temperature measurement



Measuring and inspection systems for metal strips, plastics and rubber



Optical micrometers and fiber optics, measuring and test amplifiers



Color recognition sensors, LED analyzers and inline color spectrometers

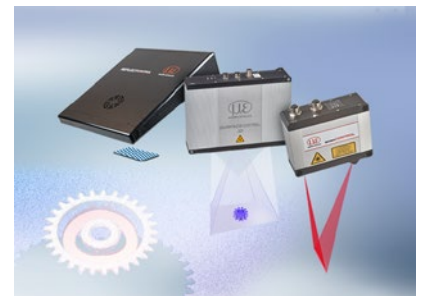

3D measurement technology for dimensional testing and surface inspection