



More Precision

capa**NCDT** // Capacitive sensors for displacement, distance & gap



Application examples

capaNCDT

Wafer stage positioning

Capacitive sensors measure the position of the stage at various points, which is required in particular for fine alignment. Thanks to their triaxial design, the sensors are insensitive to electromagnetic fields and achieve a resolution in the nanometer range. They also achieve extremely high long-term stability. The sensors are designed for vacuum applications and can be used up to ultra-high vacuum.

Measuring system: capaNCDT 6200 with CSH/SE-sensors

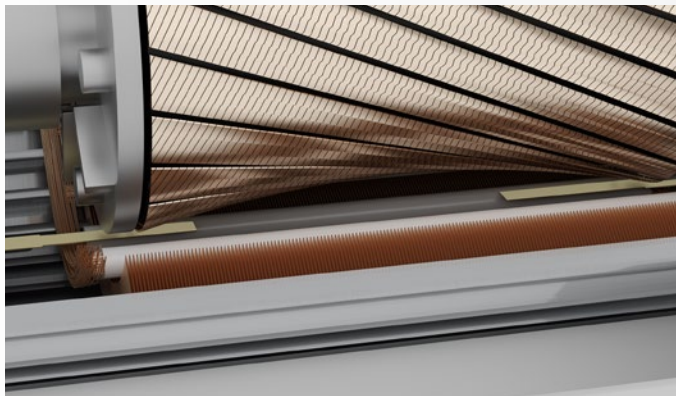
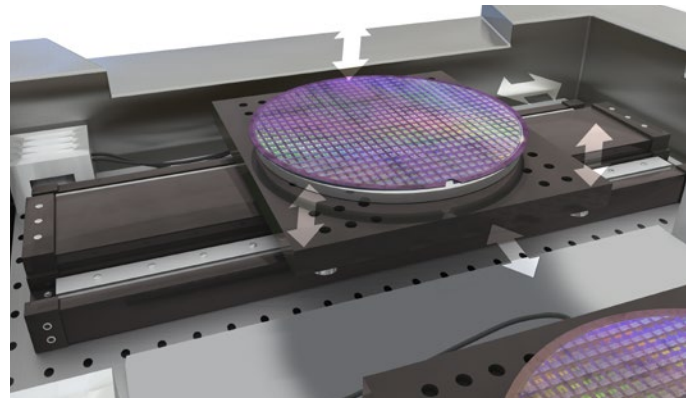

Air gap in generators and electric motors

Capacitive sensors measure the air gap between a rotor and a stator. Thanks to their small and flat design, they are easy to integrate and can also be used in confined installation spaces such as electric motors. The sensors are used both on test benches and permanently integrated into the motor or generator. For service purposes, sensors measuring on both sides can also be inserted manually into the gap.

Measuring system: capaNCDT DT6200 with CSG & CSF sensors

Expansion of battery cells during initial charging

At the end of the battery cell production process, the cell undergoes a functional and quality test. This is carried out during the battery's initial charging process. During charging, the expansion of the cell is monitored by a capacitive sensor with high resolution and micrometer accuracy. In combination with additional measured variables, such as pressure, conclusions can be drawn about quality and safety.

Measuring system: capaNCDT 6200 with CS sensors

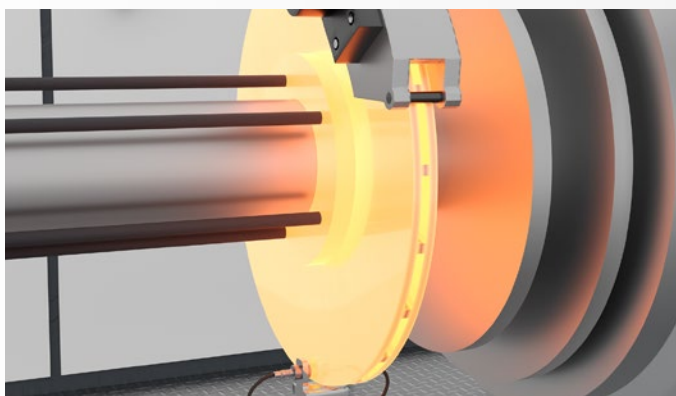
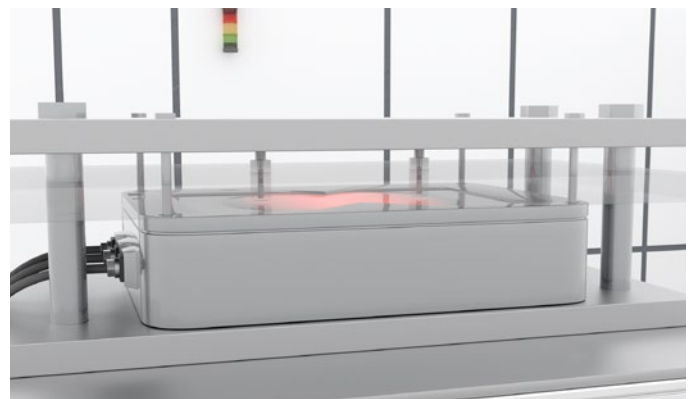

Thickness measurement of brake discs

Capacitive high-temperature sensors enable non-contact measurement of brake disc runout, deformation, and disc thickness variation. They are used on test benches, in road tests, and in workshops.

Measuring system: capaNCDT 6229(02)/DTV with CSE/HT sensors

Roller gap measurement in calendering processes

In calendering processes, such as battery film production, strip materials are rolled to an exact thickness. To ensure precise control of this process, it is not the material itself that is measured, but the gap between the calender rolls. Special capacitive gap sensors provide highly precise gap measurement.

Measuring system: capaNCDT 6200 with CSG sensors

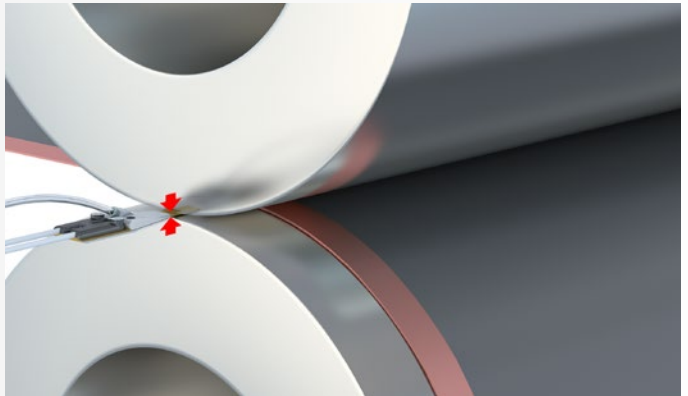

Mask positioning in lithography

Capacitive displacement sensors are used for the highly precise alignment and long-term stable monitoring of lithography masks. The sensors measure the z-position of air- or magnetically levitated masks so that the correct height is maintained with nanometer precision. The multi-channel controllers also provide virtual grounding of the target object via four sensors.

Measuring system: capaNCDT 6500 with CSH-FL sensors

Powder bed height in 3D printing

In metal 3D printing and laser sintering, precision components are built up from many thin powder layers. To ensure high component quality, these layers must be applied uniformly and evenly. Capacitive sensors integrated into the build platform precisely monitor the small movements as the platform is lowered and the next powder layer is applied. At the same time, the blade used to spread the powder layer is aligned with high precision, and the height of the powder bed is determined with micrometer accuracy.

Measuring system: capaNCDT 6100 with CS sensors

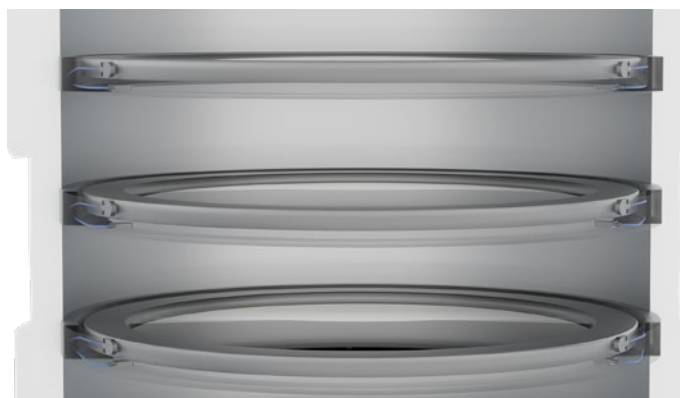
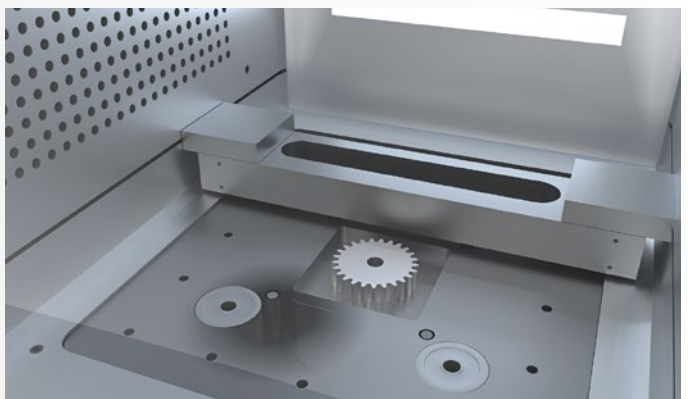

Alignment of lenses and optical systems

Capacitive displacement sensors are used for the alignment and fine positioning of mounted lenses. The lenses must be positioned precisely in the beam path of an optical unit, for example in a lithography machine. The lateral distance in X and Y is measured by the capacitive sensors with nanometer accuracy. Piezo actuators then move the lens into the required position.

Measuring system: capaNCDT 6200 with CSH/SE flat sensors

Capacitive sensors

Best practices for optimal measurements

A capacitive sensor measures the distance to an object based on the change in electrical capacitance between two electrodes. The two electrodes are formed by the sensor and the opposing measuring object. If a constant alternating current flows through the sensor, the amplitude of the AC voltage at the sensor is directly proportional to the distance between the two electrodes. In addition to the measuring principle, other physical properties and relationships must also be taken into account when selecting a sensor, as briefly explained below.



Active measuring area
Measurement spot (Minimum size of the measuring object)

Minimum size of the measuring object

The capaNCDT sensors generate their measurement results from a measurement spot. The size of this spot is decisive for the size of the target object, and vice versa. For precise and stable measurements, the minimum size of a flat target object must be maintained, or a special factory calibration must be carried out. Recommendations for target object size can be found in the technical data and on pages 58 and 59.

Sensor size
Measuring range

Measuring range and sensor size

The capacitive measuring principle is based on the direct relationship between the measuring range, sensor size and measurement spot. This means that larger measuring ranges require larger housings, which results in a larger measurement spot. The sensor's measuring range starts directly at the measurement area (at "0") and extends up to the end of its calibrated measuring range (max. 20 mm with the CS-10/B).

Linearity and resolution

The resolution values specified in the technical data describe a static and a dynamic application. The values were recorded with the DT6530 controller at 2 Hz (static resolution) and 8.5 kHz (dynamic resolution). If a different controller or a different measuring rate is used, the resolution also changes (see figure on page 40).

The same applies to linearity, which describes the accuracy of the sensor. The value depends on the controller and must be added to the controller linearity. To optimize linearity, an additional linearity calibration can be carried out at the factory.

"Replacement accuracy": This value indicates the linearity achieved after replacement (without recalibration).

Maximum versatility for every application

Micro-Epsilon offers the world's leading portfolio of sensors, featuring a wide range of standard and custom models for various applications.

Depending on the operating conditions, various housing and potting materials are used, including:

- Special alloys (e.g. Inconel) for high temperatures
- Stainless steel for cleanroom/vacuum
- Titanium for applications in strong magnetic fields
- Invar for highest temperature stability

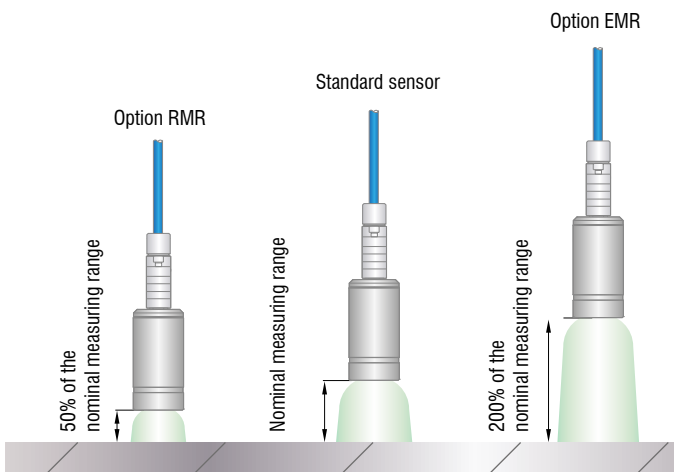
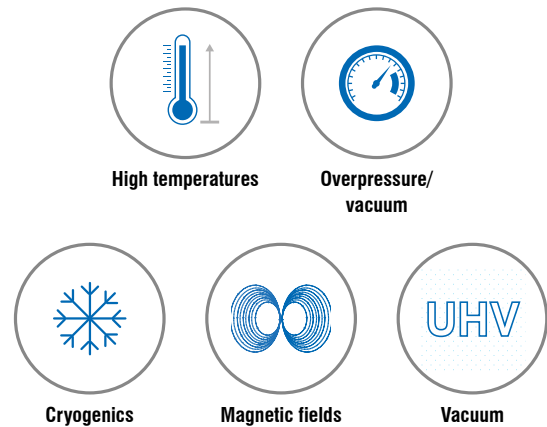

Extension and reduction of the measuring range

To increase the sensors' flexibility, their measuring ranges can be extended by a factor of 2 or reduced by a factor of 0.5 through factory calibration of the controller.

You can find the corresponding measuring ranges in the technical specifications under "reduced" or "extended". This allows existing sensor designs to be used for larger measuring ranges or to improve measurement accuracy by reducing the measuring range.

Optimal mounting for maximum temperature stability

Capacitive sensors from Micro-Epsilon are mounted in different ways depending on their design. In most cases, installation is done using a circumferential clamp or a clamp secured with a set screw. However, some sensors can also be screwed in place, either directly using a thread in the housing or with mounting screws.

In the technical data, you will find the specifications for the "Recommended mounting position". This indicates the optimal mounting or clamping point at which maximum temperature stability, and thus the highest possible precision, is achieved.

This is followed by the clamping area, where clamping fastening is possible.

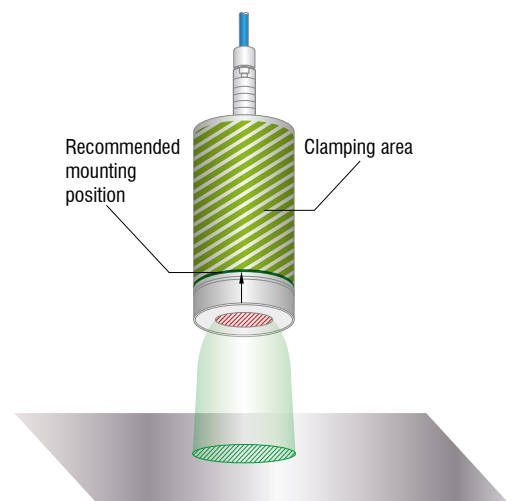

High-precision cylindrical sensors (integrated cable)

capaNCDT CSH



Model		CSH02-CAm1,4	CSH05-CAm1,4	CSH1-CAm1,4	CSH1,2-CAm1,4	CSH2-CAm1,4
Measuring range	Reduced	0.1 mm	0.25 mm	0.5 mm	0.6 mm	1 mm
	Nominal	0.2 mm	0.5 mm	1 mm	1.2 mm	2 mm
	Extended	0.4 mm	1 mm	2 mm	2.4 mm	4 mm
Resolution ^[1]	Static	0.06 nm	0.15 nm	0.3 nm	0.36 nm	0.6 nm
	Dynamic	4 nm	10 nm	20 nm	24 nm	40 nm
Linearity ^[2]		< ±0.08 μm	< ±0.35 μm	< ±0.6 μm	< ±1.2 μm	< ±0.6 μm
Replacement accuracy ^[3]		< ±0.5 % FSO	< ±0.2 % FSO	< ±0.2 % FSO	< ±0.2 % FSO	< ±0.2 % FSO
Temperature stability ^[4]		-0.01 μm / K	+0.01 μm / K	+0.056 μm / K	+0.052 μm / K	+0.152 μm / K
Recommended target size (flat) ^[5]		Ø 7 mm	Ø 7 mm	Ø 11 mm	Ø 11 mm	Ø 17 mm
Active measuring area		Ø 2.6 mm	Ø 4.1 mm	Ø 5.7 mm	Ø 6.3 mm	Ø 8.1 mm
Connection		integrated cable with connector (type B); standard length 1.4 m				
Mounting		Circumferential clamping				
Temperature range	Storage	-50 ... 200 °C				
	Operation	-50 ... 200 °C				
Shock (DIN EN 60068-2-27)		30g / 5 ms in XY axis, 1000 shocks each				
Vibration (DIN EN 60068-2-6)		20 g / 58 ... 2000 Hz in XY axis, 10 cycles each				
Protection class (DIN EN 60529)		IP40				
Material		1.4104 (magn.)				
Weight		approx. 30 g (incl. cable)	approx. 30 g (incl. cable)	approx. 33 g (incl. cable)	approx. 33 g (incl. cable)	approx. 38 g (incl. cable)
Recommended mounting position ^[6]		3 mm				
Compatibility		Compatible with all capacitive controllers from Micro-Epsilon Sensors can be replaced as required without recalibration (see replacement accuracy)				

^[1] RMS noise referred to the end of the measuring range and to the nominal measuring range using the standard cable CCm (1.4 m); valid for operation with the DT6530: static 2 Hz, dynamic 8.5 kHz

^[2] Typical linearity to be added to the controller linearity; valid for standard cable adjustment CCm (1.4 m)

^[3] FSO = Full Scale Output | The value corresponds to the slope error that occurs when a sensor is replaced without recalibration

^[4] In recommended mounting position; from a temperature of +120 °C: non-linear signal drift

^[5] In relation to the nominal measuring range

^[6] From the sensor front face (measuring surface), opposite to the measuring direction

Mounting of cylindrical CSH sensors

CSH-type cylindrical sensors can be installed either protruding (with the sensor extending beyond the mounting bracket) or flush with the mounting bracket. The sensor is mounted either by point clamping using a plastic set screw or by circumferential clamping using a collet. When using circumferential clamps, please note that the surrounding material may cause heat buildup.

The technical specifications always refer to circumferential clamping at the recommended mounting position.

Recommended mounting of CSH sensors



With set screw

With circumferential clamping

CSH02-CAm1,4

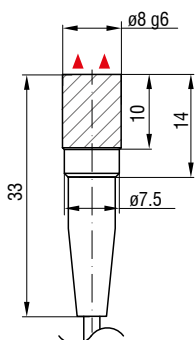

CSH05-CAm1,4

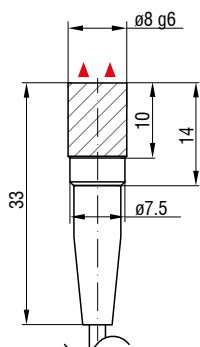

CSH1-CAm1,4

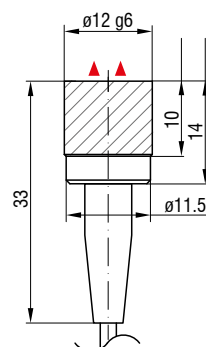

CSH1,2-CAm1,4

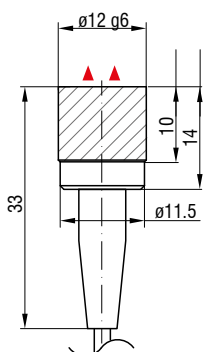

CSH2-CAm1,4

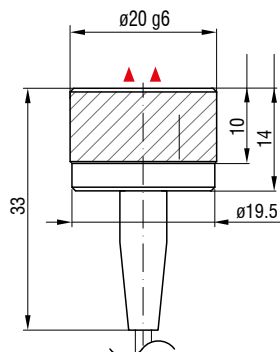

▲ ▲ Measurement direction

(dimensions in mm, not to scale)

Dimensions

capa^{NC}DT CSF

Flat sensors with integrated sensor cable

CSF2-CRg4.0

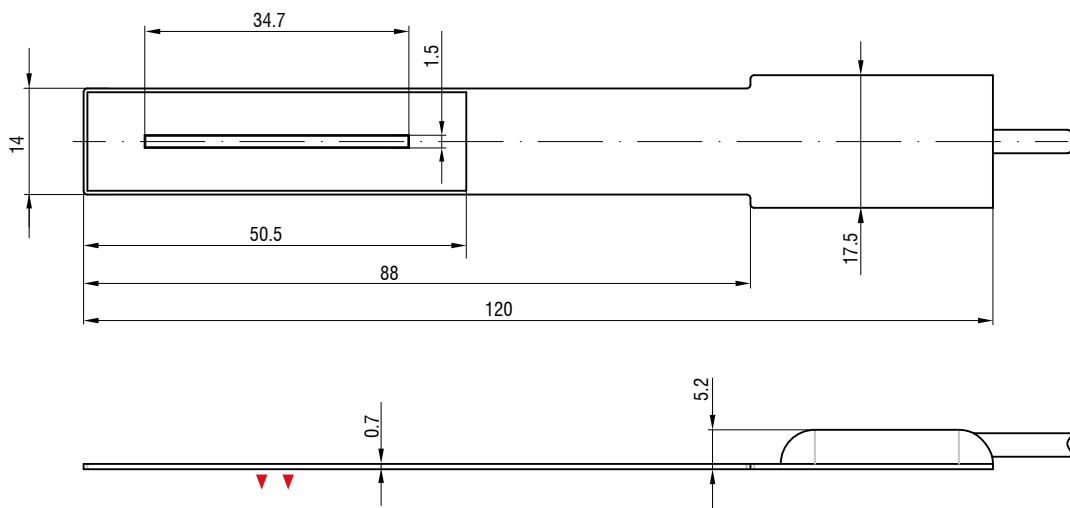

CSF4-CRg4.0

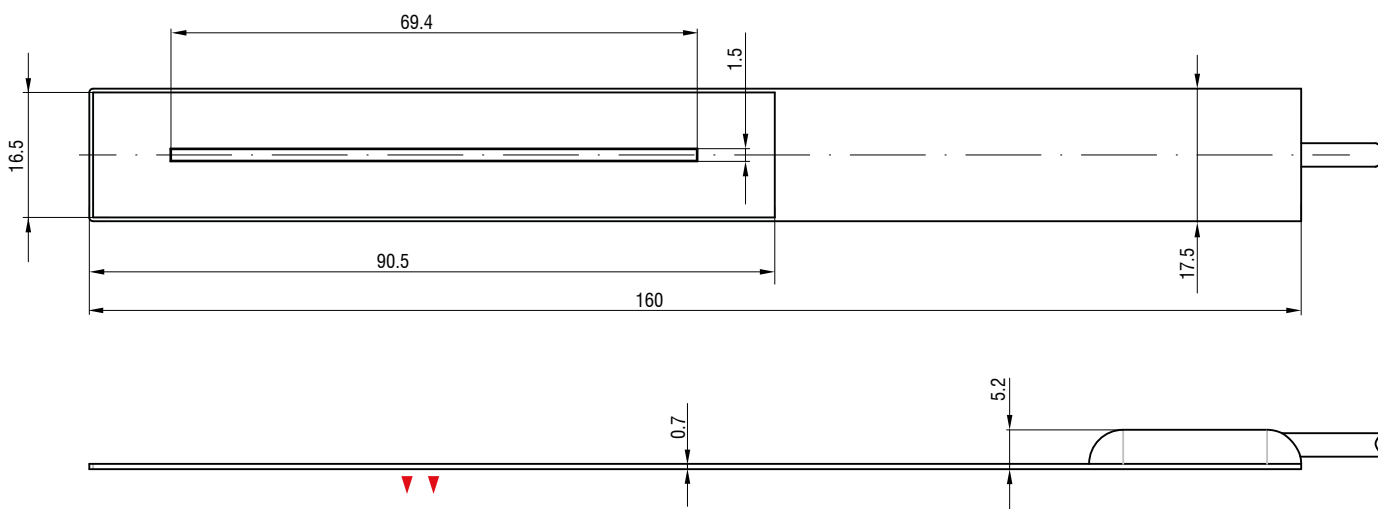

CSF6-CRg4.0

