



Instruction Manual
thermoMETER CS

Infrared sensor

MICRO-EPSILON
MESSTECHNIK
GmbH & Co. KG
Königbacher Strasse 15

94496 Ortenburg / Germany

Tel. +49 (0) 8542 / 168-0
Fax +49 (0) 8542 / 168-90
e-mail info@micro-epsilon.de
www.micro-epsilon.com

Certified acc. to DIN EN ISO 9001: 2008

Contents

1.	Safety	5
1.1	Symbols Used	5
1.2	Warnings	5
1.3	Notes on CE Identification	6
1.4	Proper Use	7
1.5	Proper Environment	7
2.	Technical Data	8
2.1	Functional Principle.....	8
2.2	General Specifications	8
2.3	Electrical Specifications.....	9
2.4	Measurement Specifications	11
3.	Delivery	12
3.1	Unpacking.....	12
3.2	Storage.....	12
4.	Optical Charts.....	13
5.	LED Functions	14
5.1	Automatic Aiming Support.....	14
5.2	Self Diagnostic	15
5.3	Temperature Code Indication	16
6.	Installation	17
6.1	Mechanical Installation	17
6.2	Electrical Installation	18
6.2.1	Analog Device (mV Output on OUT Pin)	18
6.2.2	Analog Device (Thermocouple Type K Output on OUT t/c K Pins / only at Model CSTK-SF15).....	18
6.2.3	Digital Communication.....	19
6.2.4	Open Collector Output.....	20
6.2.5	Direct Connection to an RS232 Interface on the Computer	20
7.	Maintenance	20
8.	Schematic Circuit Diagrams for Maintenance Applications	21

9.	Software	23
9.1	Installation	23
9.2	Minimum System Requirements.....	23
9.3	Main Features.....	24
9.4	Communication Settings	24
10.	Digital Command Set	25
11.	Basics of Infrared Thermometry	27
12.	Emissivity	28
12.1	Definition	28
12.2	Determination of Unknown Emissivities	28
12.3	Characteristic Emissivities	29
13.	Warranty	29
14.	Service, Repair	30
15.	Decommissioning, Disposal	30
Appendix		
A 1	Accessories	31
A 1.1	Mounting Accessories	31
A 1.2	Close Focus Optics.....	32
A 1.3	Air Purge Collars	33
A 1.4	Further Accessories	34
A 2	Factory Default Settings	35
A 3	Appendix A - Emissivity Table Metals	38
A 4	Appendix B Emissivity Table Non Metals	39
A 5	Appendix C - Smart Averaging	40

1. Safety

The handling of the system assumes knowledge of the instruction manual.

1.1 Symbols Used

The following symbols are used in the instruction manual.



Indicates a hazardous situation which, if not avoided, may result in minor or moderate injuries.



Indicates a situation which, if not avoided, may lead to property damage



Indicates a user action.



Indicates a user tip.

Measure

Indicates a hardware or a button/menu in the software

1.2 Warnings



Connect the power supply and the display/output device in accordance with the safety regulations for electrical equipment.

> Danger of injury

> Damage to or destruction of the sensor



Avoid shock and vibration to the sensor.

> Damage to or destruction of the sensor

The power supply must not exceed the specified limits.

> Damage to or destruction of the sensor

Protect the sensor cable against damage.

> Destruction of the sensor, Failure of the measuring device

Do not kink the sensor cable and bend the sensor cable in tight radius. The minimum bending radius is 14 mm (static). A dynamic movement is not allowed.

> Damage to the sensor cable, failure of the measuring device

No solvent-based cleaning agents may have an effect on the sensor (neither for the optics nor the housing)

> Damage to or destruction of the sensor

1.3 Notes on CE Identification

The following applies to the thermoMETER CS:

- EU directive 2004/108/EC
- EU directive 2011/65/EU, "RoHS" category 9

Products which carry the CE mark satisfy the requirements of the quoted EU directives and the European standards (EN) listed therein. The EC declaration of conformity is kept available according to EC regulation, article 10 by the authorities responsible at

MICRO-EPSILON MESSTECHNIK

GmbH & Co. KG

Königbacher Straße 15

94496 Ortenburg / Germany

The system is designed for use in industry and laboratory and satisfies the requirements.

1.4 Proper Use

- The thermoMETER CS is designed for use in industrial and laboratory areas. It is used for non-contact temperature measurement.
- The system may only be operated within the limits specified in the technical data, see Chap. 2..
- Use the system in such a way that in case of malfunctions or failure personnel or machinery are not endangered.
- Take additional precautions for safety and damage prevention for safety-related applications.

1.5 Proper Environment

- Protection class: IP 65 (NEMA 4)
- Operating temperature: See also Chapter Measurement Specification, see Chap. 2.4

NOTICE

Avoid abrupt changes of the operating temperature of both the sensor and the controller.

> Inaccurate measuring values

- Storage temperature: -40 ... 85 °C (-40 ... +185 °F)
- Humidity: 10 ... 95 %, non-condensing

2. Technical Data

2.1 Functional Principle

The sensors of the CS series are non-contact infrared temperature sensors. They calculate the surface temperature based on the emitted infrared energy of objects, see Chap. 11.

The sensor housing of the CS is made of stainless steel (IP 63) and contains the complete sensor electronics. The CS has a fixed mounted connection cable.

i The sensors CS are sensitive optical systems. Please use only the thread for mechanical installation.

NOTICE

Avoid mechanical violence on the sensor
> Destruction of the sensor.

2.2 General Specifications

Environmental rating	IP 63
Ambient temperature	-20 ... 80 °C
Storage temperature	-40 ... 85°C
Relative humidity	10 ... 95 °C, non condensing
Material	Stainless steel
Dimensions	M12x1, 85 mm long
Weight	58 g
Cable length	1 m (standard), 3 m, 8 m, 15 m
Kabeldurchmesser	4,3 mm
Vibration	IEC 68-2-6: 3 G, 11 - 200 Hz, any axis
Shock	IEC 68-2-27: 50 G, 11 ms, any axis

2.3 Electrical Specifications

Used pin		Function	
OUT	IN/OUT		
x		Analog	0 - 5 V ¹⁾ or 0 - 10 V ²⁾ / scalable
x		Alarm	output voltage adjustable; N/O or N/C
x		Alarm	3-state alarm output (three voltage level for no alarm, pre-alarm, alarm)
	x	Alarm	programmable open collector output [0 - 30 V DC/ 50 mA] ⁴⁾
	x	Temp. Code	Temp. Code Output (open collector [0 - 30 V DC/ 50 mA] ⁴⁾)
	x	Input	programmable functions: - external emissivity adjustment - ambient temperature compensation - triggered signal output and peak hold function ⁵⁾
x	x	Serial digital ³⁾	uni- (burst mode) or bidirectional
OUT t/c K		Analog	Thermocouple output type K (only at model CSTK-SF15); alternatively selectable to the mV output (software necessary)
Status LED		green LED with programmable functions: - alarm indication (threshold independent from alarm outputs) - automatic aiming support - self diagnostics - temperature code indication	

Vcc adjust mode	10 adjustable emissivity and alarm values by variation of supply voltage/ Service mode for analog output
Output impedances	min. 10 kΩ load impedance
Current draw	10 mA
Power supply	5 ... 30 VDC

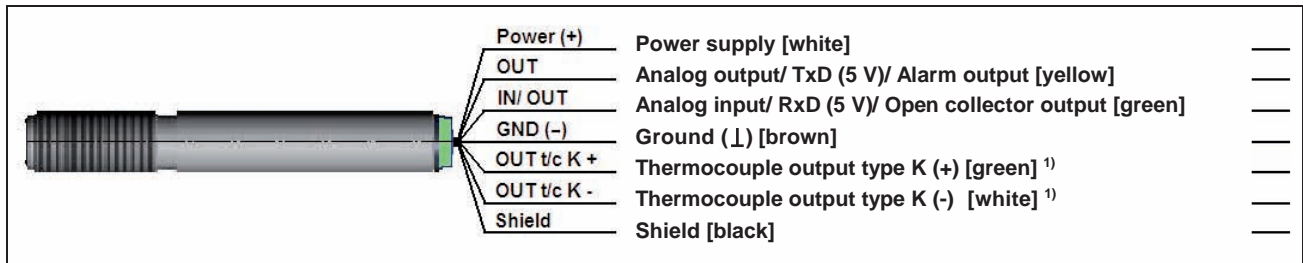

- 1) 0 ... 4.6 V at supply voltage; also valid for alarm output
- 2) Only at supply voltage ≥ 11 V
- 3) Inverted RS232-Signal, TTL, 9.6 kBaud
- 4) Loadable up to 500 mA if the mV output is not used
- 5) High level: > 0.8 V/ Low level: < 0.8 V
- 6) Only at model CSTK-SF15/ the t/c wires are indicated with an additional cable marker to avoid wrong connections due to the identical cable colors of other wires (white, green)

2.4 Measurement Specifications

Temperature range	-40 ... 400 °C (scalable via software); (optional up to 1030 °C)
Spectral range	8 ... 14 μm
Optical resolution	15:1
CF-lens (optional)	0.8 mm@ 10 mm
Accuracy ¹⁾	± 1.5 °C or ± 1.5 % of reading (whichever is greater)
Repeatability ¹⁾	± 0.75 °C or ± 0.75 % of reading (whichever is greater)
Temperature coefficient ²⁾	± 0.05 K/ K or ± 0.05 %/ K (whichever is greater)
Temperature resolution (NETD) ³⁾	0.1 K
Response time	25 ms (95 % signal/ adjustable up to 999 s via software)
Warm-up time	10 min
Emissivity/ Gain	0.100 ... 1.100 (adjustable via 0 - 5 VDC input or software)
Transmissivity	0.100 ... 1.000 (adjustable via software)
Interface (optional)	USB programming interface
Signal processing	Average, Peak hold, Valley hold, Advanced peak hold with threshold and hysteresis, Triggered signal output, Triggered peak hold function (adjustable via software)
Software	optional

1) at ambient temperature 23 ± 5 °C and object temperatures > 0 °C

2) for ambient temperatures < 18 °C and > 28 °C

3) at time constant ≥ 100 ms with smart averaging and an object temperature of 25 °C

3. Delivery

3.1 Unpacking

- 1 thermoMETER CS sensor
- 1 Connection cable
- 2 Mounting nuts
- 1 Instruction manual

 Check the delivery for completeness and shipping damage immediately after unpacking.

 In case of damage or missing parts, please contact the manufacturer or supplier.

Optional accessories you will find in the Chapters

- Mounting Accessories, see Chap. [A 1.1](#)
- CF Lens, see Chap. [A 1.2](#)
- Air Purge Collars, see Chap. [A 1.3](#)
- Further Accessories, see Chap. [A 1.4](#)

3.2 Storage

- Storage temperature: -40 ... 85 °C (-40 ... +185 °F)
- Humidity: 10 ... 95 %, non-condensing

4. Optical Charts

The following optical charts show the diameter of the measuring spot in dependence on the distance between measuring object and sensor. The spot size refers to 90 % of the radiation energy. The distance is always measured from the front edge of the sensor housing/ CF-lens holder/ air purge.

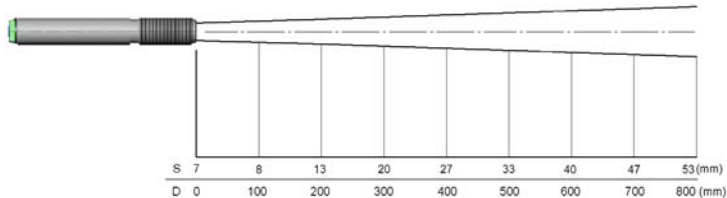

Fig. 1 Optical chart (15:1)

i The size of the measuring object and the optical resolution of the infrared thermometer determine the maximum distance between sensor and measuring object. In order to prevent measuring errors the object should fill out the field of view of the optics completely. Consequently, the spot should at all times have at least the same size like the object or should be smaller than that.

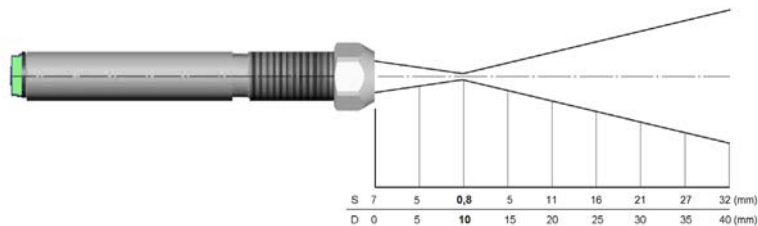

Fig. 2 Optical chart (15:1) with CF-lens (0.8 mm@ 10 mm)

5. LED Functions

The green LED can be programmed for the following functions. For the programming the USB adapter cable inclusive software (option) is necessary. The factory default setting for the LED is self diagnostic.

LED Alarm	LED lights up if the object temperature exceeds or deceeds an alarm threshold.
Automatic aiming support	Sighting feature for an accurate aiming of the CS to hot or cold objects
Self diagnostic	LED is indicating different states of the sensor.
Temperature Code indication	Indication of the object temperature via the LED
Off	LED deactivated

5.1 Automatic Aiming Support

The automatic aiming support helps to adjust the unit to an object which has a temperature different to the background. If this function is activated via software the sensor is looking for the highest object temperature; means the threshold value for activating the LED will be automatically tuned.

This works also if the sensor is aimed at a new object (with probably colder temperature). After expiration of a certain reset time (default setting: 10 s) the sensor will adjust the threshold level for activation of the LED new.

5.2 Self Diagnostic

With this function the current status of the sensor will be indicated by different flash modes of the LED.

If activated, the LED will show one of five possible states of the sensor:	
Status	LED mode
Normal	intermittent off - - - - -
Sensor overheated	fast flash - - - - -
Out of measuring range	double flash - - - - -
Not stable	intermittent on - - - - -
Alarm fault	always on - - - - -

i At a supply voltage (V_{cc}) ≥ 12 V it takes about 5 minutes until the sensor works in a stable mode. Therefore, after switching on the unit, the LED will show a not stable state for up to 5 minutes.

- Sensor overheated: The internal temperature probes have detected an invalid high internal temperature of the CS.
- Out of meas. range: The object temperature is out of measuring range.
- Not stable: The internal temperature probes have detected an unequally internal temperature of the CS.
- Alarm fault: Current through the switching transistor of the open-collector output is too high.

5.3 Temperature Code Indication

With this function the current measured object temperature will be indicated as percentage value by long and short flashing of the LED.

At a range setting of 0 - 100 °C → 0 - 100 % the LED flashing indicates the temperature in °C.

Long flashing → first digit:	xx
Short flashing → second digit:	xx
10-times long flashing → first digit = 0:	0x
10-times short flashing → second digit = 0:	x0

Examples:

87 °C	8-times long flashing indicates	87
and afterwards	7-times short flashing indicates	87
31 °C	3-times long flashing indicates	31
and afterwards	1-times short flashing indicates	31
8 °C	10-times long flashing indicates	08
and afterwards	8-times short flashing indicates	08
20 °C	2-times long flashing indicates	20
and afterwards	10-times short flashing indicates	20

6. Installation

6.1 Mechanical Installation

The CS is equipped with a metric M12x1 thread and can be installed either directly via the sensor thread or with the help of the both hex nuts (standard) to the mounting bracket available.

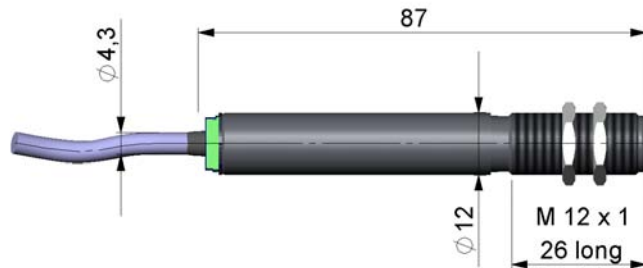

For an exact aiming of the sensor to an object the LED function Automatic Aiming Support, see Chap. 5.1, can be used.

6.2 Electrical Installation

6.2.1 Analog Device (mV Output on OUT Pin)

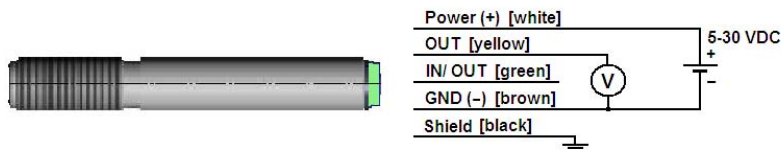

The output impedance must be $\geq 10 \text{ k}\Omega$.

6.2.2 Analog Device (Thermocouple Type K Output on OUT t/c K Pins / only at Model CSTK-SF15)

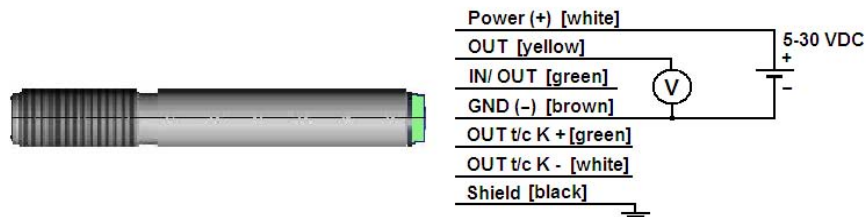

The output impedance must be $\geq 20 \text{ k}\Omega$.

On the model CSTK-SF15 you can choose between a mV output (0 - 5 or 0 - 10 V; scalable via software) and a thermocouple output type K.

The factory default setting is 0 - 3.5 V (according to 0 - 350 °C); the thermocouple output is inactive, see Chap. [A 2](#).

To activate the thermocouple output the USB adapter cable and the software is needed. This output supplies a voltage according to the characteristic curve type K.

If you want to extend this output you have to use a suitable thermocouple extension cable (NiCr-Ni).

- The shield [black] on the CS is not connected to GND [brown].
- In any case it is necessary to connect the shield to ground or GND (whichever works best)!

6.2.3 Digital Communication

For a digital communication the optional USB programming kit is required. Please connect each wire of the USB adapter cable with the same colored wire of the sensor cable by using the terminal block. Press with a screw driver as shown in the picture to loose a contact.

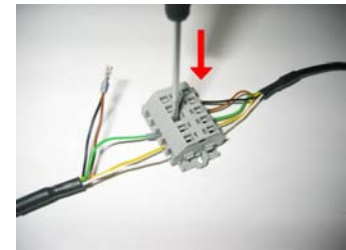

The sensor is offering two ways of digital communication:

- bidirectional communication (sending and receiving data)
- unidirectional communication (burst mode - the sensor is sending data only)

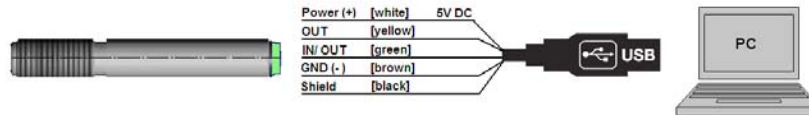

6.2.4 Open Collector Output



The open collector output is an additional alarm output on the CS and can control an external relay e.g. In addition the analog output can be used simultaneously.

6.2.5 Direct Connection to an RS232 Interface on the Computer

The CS works with a UART voltage of 3.3 V. For a bidirectional RS232 connection of the sensor the following interface circuits can be used: MAX3380 or MAX3321 (manufacturer: Maxim).

7. Maintenance

Lens cleaning: Blow off loose particles using clean compressed air. The lens surface can be cleaned with a soft, humid tissue moistened with water or a water based glass cleaner.

- **i** Never use cleaning compounds which contain solvents (neither for the lens nor for the housing).

8. Schematic Circuit Diagrams for Maintenance Applications

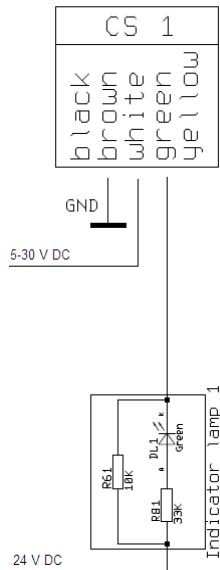

Fig. 3 Open collector output for direct 24 VDC signal lamp control

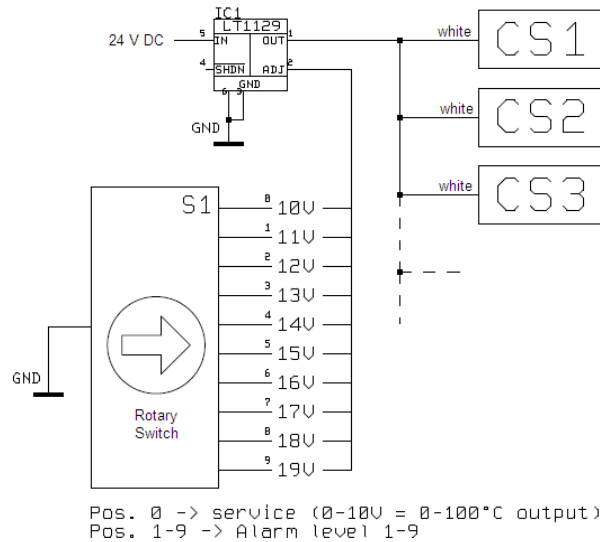

Fig. 4 Common power supply voltage change to adjust simultaneously alarm levels and emissivity values [Vcc adjust mode]

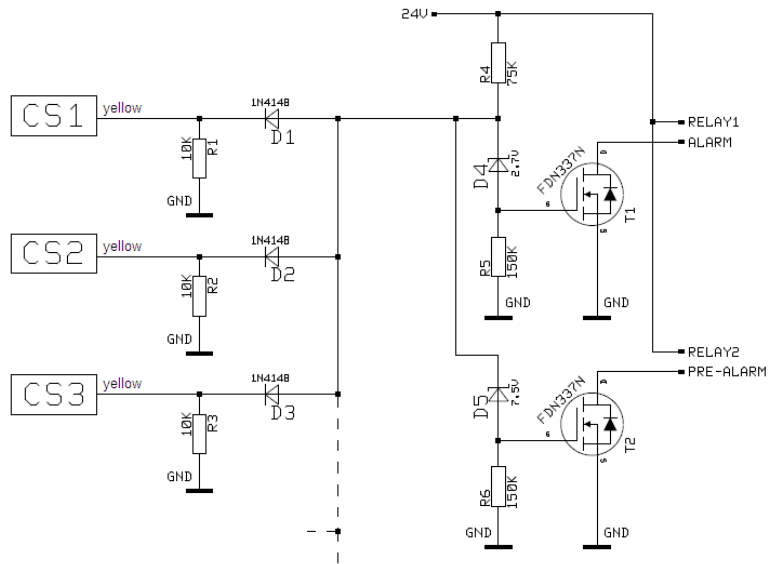

Fig. 5 Simple common alarm and pre-alarm generation

9. Software

9.1 Installation

Insert the installation CD into the according drive on your computer. If the autorun option is activated the installation wizard will start automatically.

Otherwise please start setup.exe from the CR-ROM. Follow the instructions of the wizard until the installation is finished.

The installation wizard will place a launch icon on the desktop and in the start menu. If you want to uninstall the software from your system please use the uninstall icon in the start menu.

i You will find a detailed software manual on the CD.

9.2 Minimum System Requirements

- Windows XP, Vista, 7
- USB interface
- Hard disc with at least 30 MByte free space
- At least 128 MByte RAM
- CD-ROM drive

9.3 Main Features

- Graphic display for temperature trends and automatic data logging for analysis and documentation
- Complete sensor setup and remote controlling
- Adjustment of signal processing functions
- Programming of outputs and functional inputs

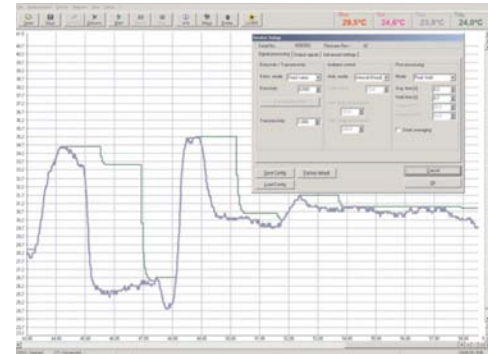

9.4 Communication Settings

Serial Interface

Baud rate: 9600 baud
Data bits: 8
Parity: none
Stop bits: 1
Flow control: off

Protocol

All sensors of the CS series are using a binary protocol. To get a fast communication the protocol has no additional overhead with CR, LR or ACK bytes.

To power the sensor the control signal „DTR“ has to be set.

10. Digital Command Set

Command list CS/ CSmicro/ CX							
Decimal	HEX	Binary / ASCII	Command	Data	Reply	Result	Unit
1	0x01	Binary	READ Temp - Target	no	byte 1 byte 2	$= (\text{byte1} \times 256 + \text{byte2} - 1000) / 10$	°C
2	0x02	Binary	READ Temp - Head	no	byte 1 byte 2	$= (\text{byte1} \times 256 + \text{byte2} - 1000) / 10$	°C
3	0x03	Binary	READ current Temp - Target	no	byte 1 byte 2	$= (\text{byte1} \times 256 + \text{byte2} - 1000) / 10$	°C
4	0x04	Binary	READ Emissivity	no	byte 1 byte 2	$= (\text{byte1} \times 256 + \text{byte2}) / 1000$	
5	0x05	Binary	READ Transmission	no	byte 1 byte 2	$= (\text{byte1} \times 256 + \text{byte2}) / 1000$	
9	0x09	Binary	READ Processor Temperature	no	byte 1	$= (\text{byte1} \times 256 + \text{byte2} - 1000) / 10$	
14	0x0E	Binary	READ Serial number	no	byte 1 byte 2 byte 3	$= \text{byte1} \times 65536 + \text{byte2} \times 256 + \text{byte3}$	
15	0x0F	Binary	READ FW Rev.	no	byte 1 byte 2	$= \text{byte1} \times 256 + \text{byte2}$	
129	0x081	Binary	SET DAC mV/ mA	byte 1	byte 1	byte1 = mV (mA) x 10 (e.g. 4 mA = 4 x 10 = 40)	°C
130	0x082	Binary	RESET of DAC mV/ mA output				
132	0x084	Binary	SET Emissivity	byte 1 byte 2	byte 1 byte 2	$= (\text{byte1} \times 256 + \text{byte2}) / 1000$	

Burstmode (unidirectional)			
After switch on a continuous serial signal will be created. The burst string can be configured with CompactConnect software.			
Burst string	Example	Complete Burst string	Conversion to decimal value
2 synchronisation bytes: AAAA	-----		-----
2 bytes for each output value (hi lo)	03B8	AAAA 03B8	Process temp. [°C] = (HEX → Dec(03B8)-1000)/10 = -4.8

Temperature calculation at CSmicro hs: $(\text{byte1} \times 256 + \text{byte2} - 10000) / 100$

Examples (all bytes in HEX):

Readout of object temperature

Send 01 Command for readout of object temperature

Receive 04 D3 Object temperature in tenth degree + 1000

04 D3 = dec. 1235
1235 - 1000 = 235
235 / 10 = 23.5 ° C

Readout of object temperature (at CSmicro 2Whs)

Send 01 Command for readout of object temperature

Receive 30 3E Object temperature in hundredth degree + 10000

Set of emissivity

Send 84 03 B6

03B6 = dec. 950

Receive 03 B6

950 / 1000 = 0.950

11. Basics of Infrared Thermometry

Depending on the temperature each object emits a certain amount of infrared radiation. A change in the temperature of the object is accompanied by a change in the intensity of the radiation. For the measurement of „thermal radiation“ infrared thermometry uses a wave-length ranging between 1μ and $20 \mu\text{m}$.

The intensity of the emitted radiation depends on the material. This material contingent constant is described with the help of the emissivity which is a known value for most materials (see enclosed table emissivity).

Infrared thermometers are optoelectronic sensors. They calculate the surface temperature on the basis of the emitted infrared radiation from an object. The most important feature of infrared thermometers is that they enable the user to measure objects contactless. Consequently, these products help to measure the temperature of inaccessible or moving objects without difficulties. Infrared thermometers basically consist of the following components:

- Lens
- Spectral filter
- Detector
- Electronics (amplifier/ linearization/ signal processing)

The specifications of the lens decisively determine the optical path of the infrared thermometer, which is characterized by the ratio Distance to Spot size.

The spectral filter selects the wavelength range, which is relevant for the temperature measurement. The detector in cooperation with the processing electronics transforms the emitted infrared radiation into electrical signals.

12. Emissivity

12.1 Definition

The intensity of infrared radiation, which is emitted by each body, depends on the temperature as well as on the radiation features of the surface material of the measuring object. The emissivity (ϵ - Epsilon) is used as a material constant factor to describe the ability of the body to emit infrared energy. It can range between 0 and 100 %. A “blackbody“ is the ideal radiation source with an emissivity of 1.0 whereas a mirror shows an emissivity of 0.1.

If the emissivity chosen is too high, the infrared thermometer may display a temperature value which is much lower than the real temperature - assuming the measuring object is warmer than its surroundings. A low emissivity (reflective surfaces) carries the risk of inaccurate measuring results by interfering infrared radiation emitted by background objects (flames, heating systems, chamottes). To minimize measuring errors in such cases, the handling should be performed very carefully and the unit should be protected against reflecting radiation sources.

12.2 Determination of Unknown Emissivities

- First, determine the actual temperature of the measuring object with a thermocouple or contact sensor. Second, measure the temperature with the infrared thermometer and modify the emissivity until the displayed result corresponds to the actual temperature.
- If you monitor temperatures of up to 380 °C you may place a special plastic sticker (emissivity dots - part number: TM-ED-LS) onto the measuring object, which covers it completely. Now set the emissivity to 0.95 and take the temperature of the sticker. Afterwards, determine the temperature of the adjacent area on the measuring object and adjust the emissivity according to the value of the temperature of the sticker.
- Cover a part of the surface of the measuring object with a black, flat paint with an emissivity of 0.98. Adjust the emissivity of your infrared thermometer to 0.98 and take the temperature of the colored surface. Afterwards, determine the temperature of a directly adjacent area and modify the emissivity until the measured value corresponds to the temperature of the colored surface.

12.3 Characteristic Emissivities

In case none of the methods mentioned above help to determine the emissivity you may use the emissivity tables, see Chap. A 3, see Chap. A 4. These are average values, only. The actual emissivity of material depends on the following factors:

- Temperature
- Measuring angle
- Geometry of the surface
- Thickness of the material
- Constitution of the surface (polished, oxidized, rough, sandblast)
- Spectral range of the measurement
- Transmissivity (e.g. with thin films)

13. Warranty

All components of the device have been checked and tested for perfect function in the factory. In the unlikely event that errors should occur despite our thorough quality control, this should be reported immediately to MICRO-EPSILON. The warranty period lasts 12 months following the day of shipment. Defective parts, except wear parts, will be repaired or replaced free of charge within this period if you return the device free of cost to MICRO-EPSILON.

This warranty does not apply to damage resulting from abuse of the equipment and devices, from forceful handling or installation of the devices or from repair or modifications performed by third parties. No other claims, except as warranted, are accepted. The terms of the purchasing contract apply in full.

MICRO-EPSILON will specifically not be responsible for eventual consequential damages.

MICRO-EPSILON always strives to supply the customers with the finest and most advanced equipment. Development and refinement is therefore performed continuously and the right to design changes without prior notice is accordingly reserved.

For translations in other languages, the data and statements in the German language operation manual are to be taken as authoritative.

14. Service, Repair

In the event of a defect on the sensor, controller or the sensor cable please send us the affected parts for repair or exchange.

In the case of faults the cause of which is not clearly identifiable, the entire measuring system must be sent back to:

For customers in USA applies:

Send the affected parts or the entire measuring system back to:

For customers in Canada or South America applies:

Please contact your local distributor.

15. Decommissioning, Disposal

➡ Disconnect the sensor cables.

Incorrect disposal may cause harm to the environment.

➡ Dispose of the device, its components and accessories, as well as the packaging materials in compliance with the applicable country-specific waste treatment and disposal regulations of the region of use.

MICRO-EPSILON MESSTECHNIK
GmbH & Co. KG
Königbacher Str. 15
94496 Ortenburg / Germany
Tel. +49 (0) 8542/ 168-0
Fax +49 (0) 8542 / 168-90
info@micro-epsilon.de
www.micro-epsilon.com

MICRO-EPSILON USA
8120 Brownleigh Dr.
Raleigh, NC 27617 /USA
Tel. +1 919 / 787-9707
Fax +1 919 / 787-9706
me-usa@micro-epsilon.com
www.micro-epsilon.com

Appendix

A 1 Accessories

A 1.1 Mounting Accessories

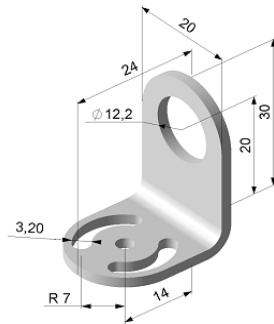

Fig. 6 Mounting bracket, adjustable in one axis [TM-FB-CS]

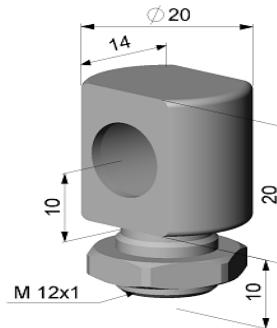

Fig. 7 Mounting bolt with M12x1 thread, adjustable in one axis [TM-MB-CS]

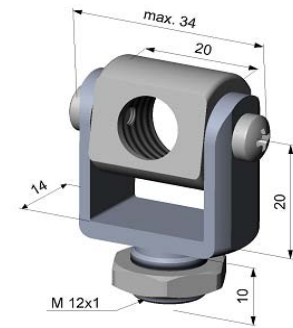

Fig. 8 Mounting fork with M12x1 thread, adjustable in two axes [TM-MG-CS]



Fig. 9 Mounting bracket, adjustable in two axis [TM-AB-CS]

i The Mounting fork can be combined with the mounting bracket [TM-FB-CS] using the M12x1 thread.

A 1.2 Close Focus Optics

The optional CF-lens allows the measurement of small objects. The CF optics can also be combined with a laminar air purge:

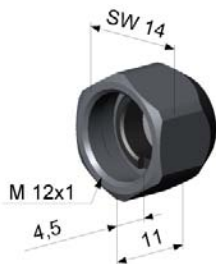

Fig. 10 CF-lens [TM-CF-CS]

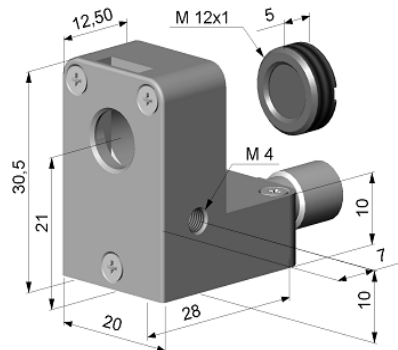

Fig. 11 Laminar air purge with integrated CF-lens [TM-APLCF-CS]

i If the CF-lens is used, the transmission has to be set to 0.78. To change this value the optional USB-Kit (including software) is necessary.

A 1.3 Air Purge Collars

The lens must be kept clean at all times from dust, smoke, fumes and other contaminants in order to avoid reading errors. These effects can be reduced by using an air purge collar. Make sure to use oil-free, technically clean air, only.

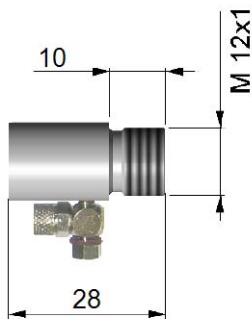

Fig. 12 Standard air purge collar; fits to the mounting bracket; hose connection: 3x5 mm [TM-AP-CS]

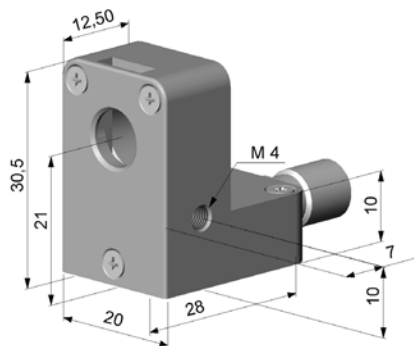

Fig. 13 Laminar air purge collar - the side air outlet prevents a cooling down of the object in short distances; hose connection: 3x5 mm [TM-APL-CS]



A combination of the Laminar air purge collar with the bottom section of the Mounting fork allows an adjustment in two axes. [TM-APL-CS + TM-MG-CS]

i The needed amount of air (ca. 2 ... 10 l/ min.) depends on the application and the installation conditions on-site.

A 1.4 Further Accessories

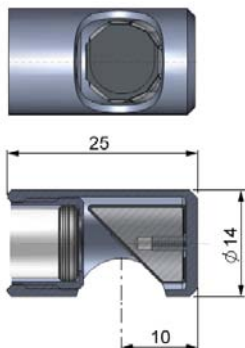

Fig. 14 Right angle mirror, enables measurement with 90 °angle [TM-RAM-CS]

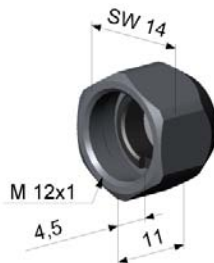

Fig. 15 Protective window, same mechanical size as CF lens [TM-PW-CS]



Fig. 16 USB-Kit: USB adapter cable inclusive terminal block and software CD [TM-USBK-CS]

i If the protective window is used, the transmission has to be set to 0.83. To change this value the optional USB-Kit (including CompactConnect software) is necessary.

All accessories can be ordered using the according part numbers in brackets [].

A 2 Factory Default Settings

The unit has the following presetting at time of delivery:

Emissivity	0.950
Transmission	1.000
Average time	0.3 s
Smart averaging	active
Smart averaging hysteresis	2 °C
Ambient temperature source	internal (sensor)
Status-LED function	Self diagnostic
Input (IN/ OUT/ green)	Communication input
Output (OUT/ yellow)	mV output
Temperature range	0 ... 350 °C
Output voltage	0 ... 3.5 V
Vcc adjust	inactive
Signal processing	Hold mode: off
Calibration	Gain 1.000/ Offset 0.0
Failsafe	inactive

i The default settings can be changed with the optional USB kit (USB adapter cable + software). If the unit is supplied together with the USB-kit the output is already preset to digital communication (bidirectional).

For a usage of the CS for online maintenance applications (in electrical cabinets e.g.) the following recommend settings are already included in the factory default setting (but not active):

OUT	At 3-state output the following settings are default:	
	Pre-alarm difference	2 °C
	No alarm level	8 V
	Pre-alarm level	5 V
	Alarm level	0 V
	Service voltage	10 V
IN/ OUT	At Alarm output (open collector) the following settings are default:	
	Mode	normally closed
	Temp code output	activated (for values above alarm level)
	Range settings	0 °C = 0 %/ 100 °C = 100 %
Vcc Adjust	If activated the following settings are default:	
	Output voltage range	0 - 10 V
	Difference mode	activated

Alarm level	Alarm value (IN/ OUT pin)	Vcc
1	40 °C	11 V
2	45 °C	12 V
3	50 °C	13 V
4	55 °C	14 V
5	60 °C	15 V
6	65 °C	16 V
7	70 °C	17 V
8	75 °C	18 V
9	80 °C	19 V
10	85 °C	20 V

A 3 Appendix A - Emissivity Table Metals

Material		Typical Emissivity
Aluminium	non oxidized	0.02 - 0.1
	polished	0.02 - 0.1
	roughened	0.1 - 0.3
	oxidized	0.2 - 0.4
Brass	polished	0.01 - 0.05
	roughened	0.3
	oxidized	0.5
Copper	polished	0.03
	roughened	0.05 - 0.1
	oxidized	0.4 - 0.8
Chrome		0.02 - 0.2
Gold		0.01 - 0.1
Haynes	alloy	0.3 - 0.8
Inconel	electro polished	0.15
	sandblast	0.3 - 0.6
	oxidized	0.7 - 0.95
Iron	non oxidized	0.05 - 0.2
	rusted	0.5 - 0.7
	oxidized	0.5 - 0.9
	forged, blunt	0.9
Iron, casted	non oxidized	0.2
	oxidized	0.6 - 0.95

Material		Typical Emissivity
Lead	polished	0.05 - 0.1
	roughened	0.4
	oxidized	0.2 - 0.6
Magnesium		0.02 - 0.1
Mercury		0.05 - 0.15
Molybdenum	non oxidized	0.1
	oxidized	0.2 - 0.6
Monel (Ni-Cu)		0.1 - 0.14
Nickel	electrolytic	0.05 - 0.15
	oxidized	0.2 - 0.5
Platinum	black	0.9
Silver		0.02
Steel	polished plate	0.1
	rustless	0.1 - 0.8
	heavy plate	0.4 - 0.6
	cold-rolled	0.7 - 0.9
	oxidized	0.7 - 0.9
Tin	non oxidized	0.05
Titanium	polished	0.05 - 0.2
	oxidized	0.05 - 0.6
Wolfram	polished	0.03 - 0.1
Zinc	polished	0.02
	oxidized	0.1

A 4 Appendix B Emissivity Table Non Metals

Material		Typical Emissivity
Asbestos		0.95
Asphalt		0.,95
Basalt		0.7
Carbon	non oxidized	0.8 - 0.9
	graphite	0.7 - 0.8
Carborundum		0.9
Ceramic		0.95
Concrete		0.95
Glass		0.85
Grit		0.95
Gypsum		0.8 - 0.95
Ice		0.98
Limestone		0.98
Paint	non alkaline	0.9 - 0.95
Paper	any color	0.95
Plastic > 50 μm	non transparent	0.95
Rubber		0.95
Sand		0.9
Snow		0.9
Soil		0.9 - 0.98
Textiles		0.95
Water		0.93
Wood	natural	0.9 - 0.95

A 5 Appendix C - Smart Averaging

The average function is generally used to smoothen the output signal. With the adjustable parameter time this function can be optimal adjusted to the respective application. One disadvantage of the average function is that fast temperature peaks which are caused by dynamic events are subjected to the same averaging time. Therefore those peaks can only be seen with a delay on the signal output. The function Smart Averaging eliminates this disadvantage by passing those fast events without averaging directly through to the signal output.

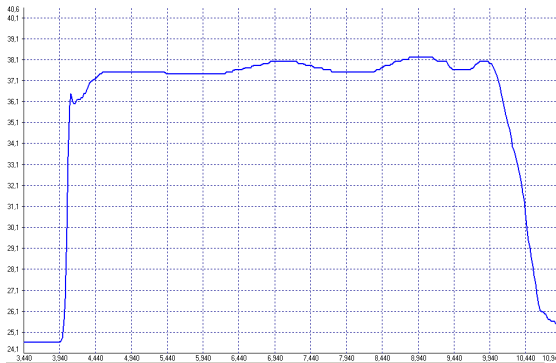

Fig. 17 Signal graph with Smart Averaging function

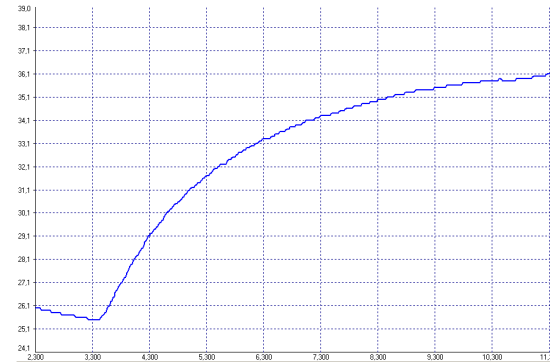

Fig. 18 Signal graph without Smart Averaging function



MICRO-EPSILON MESSTECHNIK GmbH & Co. KG
Königbacher Str. 15 · 94496 Ortenburg / Germany
Tel. +49 (0) 8542 / 168-0 · Fax +49 (0) 8542 / 168-90
info@micro-epsilon.de · www.micro-epsilon.com

X9751203-B041026HDR
© MICRO-EPSILON MESSTECHNIK

