

colorSENSOR OT Series

colorSENSOR OT-3-HR-200

- Focused white-light area for dark/mat surfaces
- Polarisation filter (for reduction of gloss effect)
- Measuring range typ. 50 mm ... 400 mm
(for contrast detection: object distance typ. up to 2 m)
- Up to 31 colors can be stored
- RS232 - interface (USB adapter available)
- 10x white-light LED, 100 kHz modulated, focused
- Color and gray scale detection, insensitive to outside light
- Brightness correction can be activated
- Several teach-functions (via PC, PLC, or push button)
- Various evaluation algorithms can be activated
- Switching state display by means of 5 yellow LEDs
- 'Averaging' can be activated (from 1 up to over 32000 values)

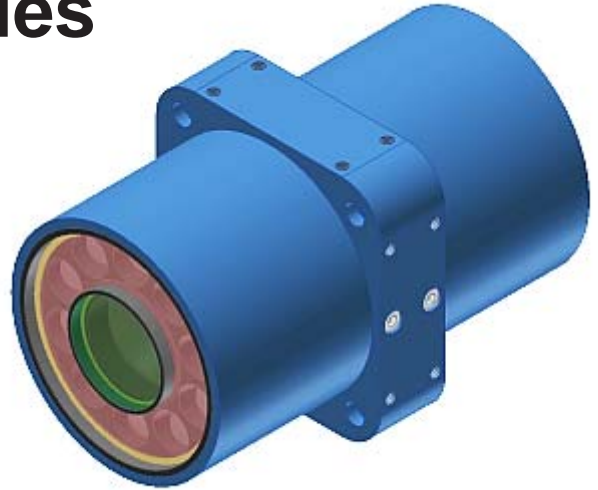

Design

Product name:

colorSENSOR OT-3-HR-200-20

(incl. software colorCONTROL C4)

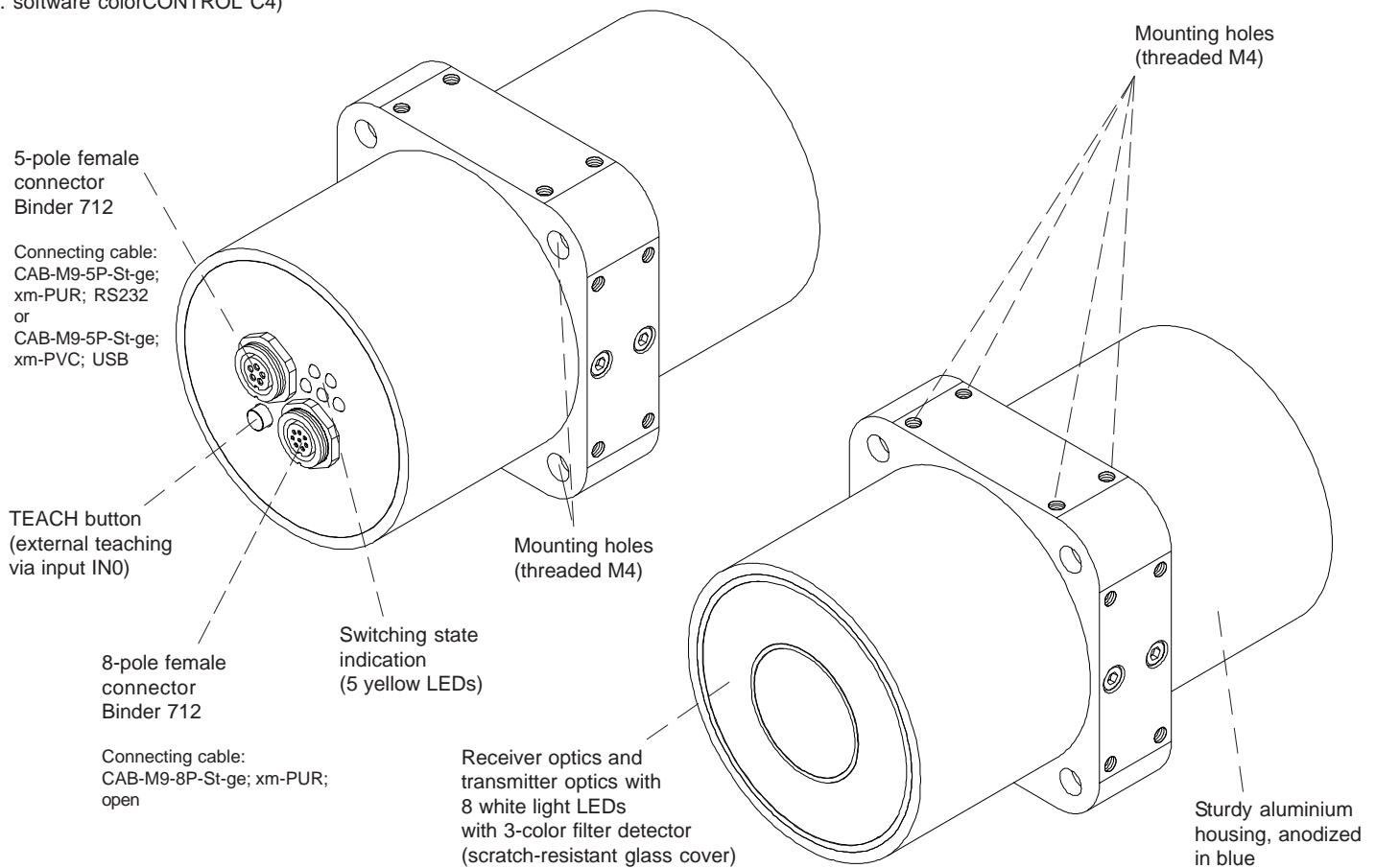

Technical Data

Type	OT-3-HR-200-20
Light source	10x white light LED, modulated 30 kHz AC-, DC-operation (adjustable or OFF in case of luminous objects adjustable via software)
Illumination technique	Polarisation filter, focused
Effect of illumination	very intense reduction of gloss effects, adapted for highly reflected surfaces
Target distance	typ. 50 mm up to 300 mm ideal distance at 200 mm
Light spot size	Ø 20 (20 dia.) mm at 200 mm
Reproducibility	in the X, Y color range each 1 digit at 12-bit A/D conversion
Color distance	$\Delta E \geq 0.8$
Receiver	3-color filter detector (TRUE COLOR Detector, color filter bend according to CIE 1931)
Alternating light operation	30 kHz
Ambient light	up to 5000 Lux
Protection light	IP 64
Current consumption	typ. 320 mA
Interface	RS 232 (USB optional)
Connector type	to PLC: 8-pole female connector (Binder series 712) to PC: 5-pole female connector (Binder series 712)
Connection cable	to PLC: CAB-M9-8P-St-ge; xm-PUR; open to PC: CAB-M9-5P-St-ge; xm-PUR; RS232 CAB-M9-5P-St-ge; xm-PVC; USB
Housing material	Aluminum, anodized in black
Operating temperature	-20°C - + 55°C (-4°F up to +131°F)
Storage temperature	-20°C - +85°C (-4°F up to +185°F)
Pulse lengthening	adjustable 0 ms up to 100 ms
Max. switching current	100 mA, short-circuit-proof
Switching frequency	max. 30 kHz (depends on the number of teach-colors and averaging value)
Outputs	OUT 0 - OUT 4, digital (0V/+Ub), short-circuit-proof 100 mA max. switching current npn-, pnp-available (bright-, dark-switching can be switched over)
Averaging	over 32768 values max.
Voltage supply	+24 VDC ($\pm 10\%$), protected against polarity reversal, overload protected
Switching state display	Visualization by means of 5 yellow LED's
Color memory capacity	non-volatile EEPROM with parameter sets for 31 colors max.
TEACH button	for external teaching of color reference values via input IN0
Temperature drift X,Y	< 0.01% / K
Signal gain	8 steps (AMP1 - AMP8), adjustable
EMC test	according to DIN EN 60947-5-2
Color spaces	X/Y INT; s/i M (Lab)

Dimensions

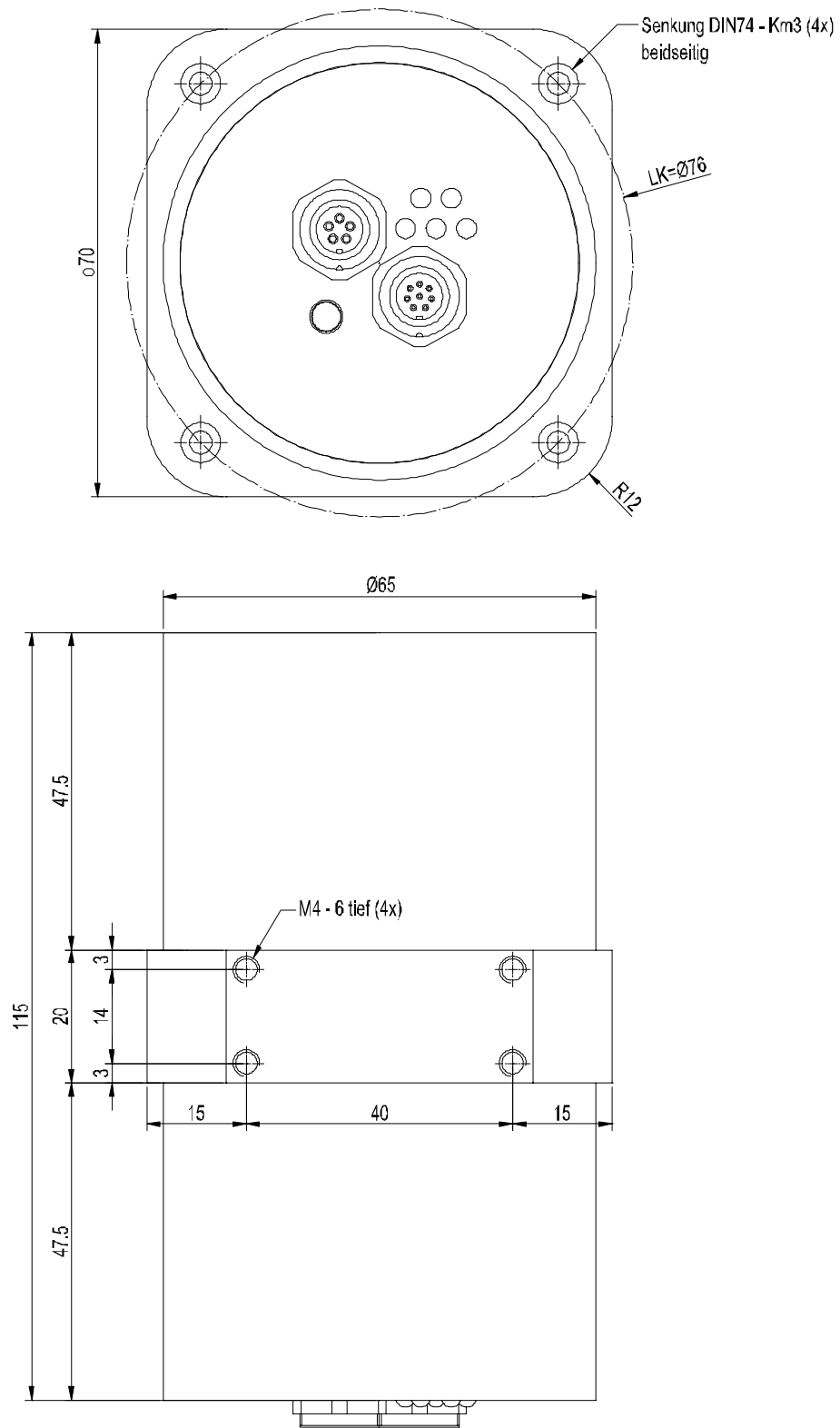

All dimensions in mm

Connector Assignment

Connection to PLC:

8-pole fem. connector Binder Series 712

Pin: Color: Assignment:

1	white	GND (0V)
2	brown	+24VDC ($\pm 10\%$)
3	green	IN0
4	yellow	OUT0
5	grey	OUT1
6	pink	OUT2
7	blue	OUT3
8	red	OUT4

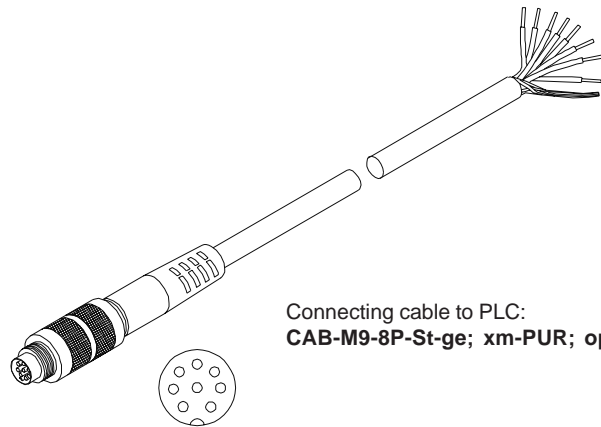
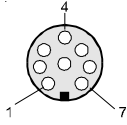

Connecting cable to PLC:
CAB-M9-8P-St-ge; xm-PUR; open

Connecting cable:

CAB-M9-8P-St-ge; 2m-PUR; open
CAB-M9-8P-St-ge; 5m-PUR; open
(Standard length 2 m)

Connection to PC:

5-pole fem. connector Binder Series 712

Connection via RS232 interface (SUB-D fem. connector)

Pin:	Assignment:
1	GND (0V)
2	TxD
3	RxD
4	+24V (+Ub, OUT)
5	not connected

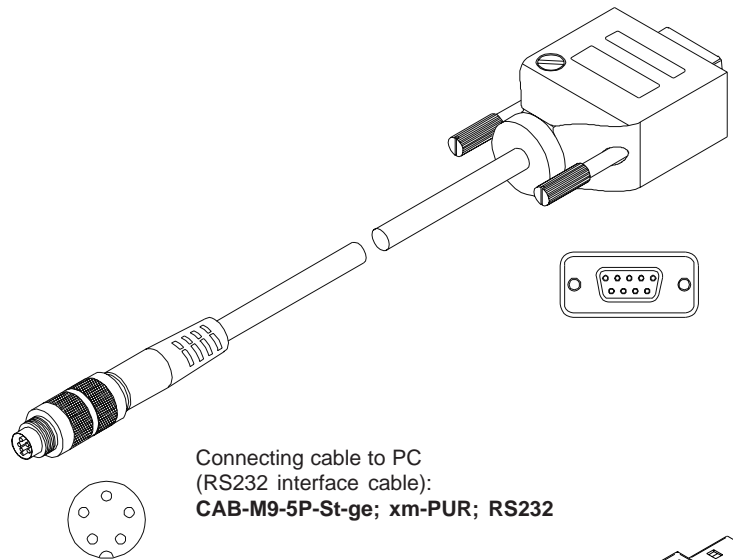
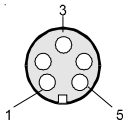

Connecting cable to PC
(RS232 interface cable):
CAB-M9-5P-St-ge; xm-PUR; RS232

Connecting cable:

CAB-M9-5P-St-ge; 2m-PUR; RS232
CAB-M9-5P-St-ge; 5m-PUR; RS232
(Standard length 2 m)

alternatively:

Connection via USB interface

Connecting cable (incl. driver software):

CAB-M9-5P-St-ge; 2m-PVC; USB
CAB-M9-5P-St-ge; 5m-PVC; USB
(Standard length 2 m)

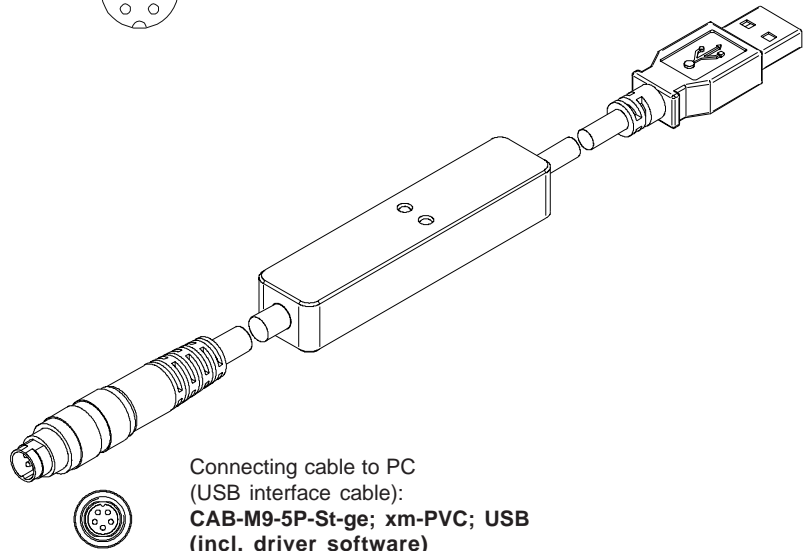

Connecting cable to PC
(USB interface cable):
**CAB-M9-5P-St-ge; xm-PVC; USB
(incl. driver software)**

Measuring Principle

Measuring principle of the colorSENSOR OT-3-HR-200:

The colorSENSOR OT-3-HR-200 color sensor detects the radiation that is diffusely reflected by the target. The colorSENSOR OT-3-HR-200 color sensor uses a white-light LED with adjustable power as a light source. A triple receiver for the RED, GREEN, and BLUE content of the light reflected from the target is used as a receiver. With the stepless adjustment of the integrated light source and the selectable gain of the receiver signal the sensor can be set to almost any surface.

The colorSENSOR OT-3-HR-200 color sensor can be "taught" up to 31 colors. Tolerances can be set for every taught color.

In X/Y INT or s/i M mode the tolerances represent a color cylinder in space. In X/Y/INT or s/i/M mode the tolerance represents a color sphere in space. Color evaluation according to s/i M and s/i/M uses the Lab calculation method. All the modes can be used in combination with various operating modes, among others "FIRST HIT" and "BEST HIT". The raw data are represented with 12 bit resolution.

Color detection either operates continuously or is started by means of an external SPC trigger signal. The respective detected color either is output as binary code at the 5 digital outputs, or it can be sent directly to the outputs, if only up to 5 colors are to be detected. Simultaneously the detected color code is visualised at the colorSENSOR OT-3-HR-200 housing by means of 5 LEDs.

With the TEACH button at the sensor housing the sensor can be taught up to 31 colors. For this purpose the corresponding evaluation mode must be set with the software. The TEACH button is connected in parallel to the input IN0 (green wire of cable CAB-M9-8P-St-ge; xm-PUR; open).

Through the RS232 interface parameters and measured values can be exchanged between the PC and the colorSENSOR OT-3-HR-200 color sensor. All the parameters for color detection can be stored in the non-volatile EEPROM of the colorSENSOR OT-3-HR-200 color sensor. When parameterization is finished the color sensor continues to operate with the current parameters in "stand alone" mode without a PC.

The sensors of the colorSENSOR OT-3-HR-200 series can be calibrated (white light balancing). Balancing can be performed to any white surface. A ColorChecker™ table with 24 color fields according to CIE standard is available as an alternative, and white light balancing or calibration can then be performed to one of the white fields.

LED Display

Visualization of the color code:

The color code is visualized by means of 5 yellow LEDs at the housing of the color sensor. At the same time the color code indicated at the LED display is output as 5-bit binary information at the digital outputs OUT0 ... OUT4 of the 8-pole PLC connector.

In the DIRECT mode the maximum number of color codes to be taught is 5. These 5 color codes can be directly output at the 5 digital outputs. The respective detected color code is displayed by means of the 5 yellow LEDs at the color sensor housing.

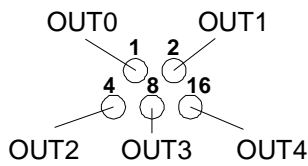
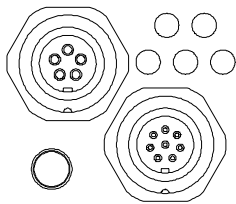

0	1	2	3
4	5	6	7
8	9	10	11
12	13	14	15
16	17	18	19
20	21	22	23
24	25	26	27
28	29	30	31
			„Error“ or „not detected“

