





More Precision

optoNCDT 1220-IO-Link // Compact laser displacement sensor with IO-Link



Compact laser sensor for OEM and serial applications with IO-Link optoNCDT 1220

-  Measuring rate 2 kHz
-  **INTER FACE** Analog (U/I) / RS422 / PROFINET / EtherNet/IP / IO-Link
-  **ASC** Active Surface Compensation
-  Repeatability 1 μm
-  Ideal for series and OEM applications
-  Low weight, ideal for high accelerations



NEW: optoNCDT 1220 with IO-Link

The optoNCDT 1220 sensor features an IO-Link interface that simplifies data communication and reduces the commissioning time.

What is IO-Link?

- Fieldbus-independent interface
- Standardized worldwide according to IEC61131-9
- Manufacturer-independent digital, bidirectional point-to-point communication
- Connection to the IO-Link master via 3-wire plug-in cables
- IO-Link can be integrated into all common fieldbus and automation systems

Advantages of IO-Link

- A uniform interface standard
- No different wiring and connection options as with conventional fieldbuses/interfaces
- Lower costs
- Less programming effort
- Faster commissioning
- Continuous communication between sensor and control unit
- Reduced troubleshooting effort due to consistent diagnostic information right down to sensor level
- Reduced downtimes, as sensor parameters can be adjusted by the control system or the operator
- Easier device replacement during operation due to automatic re-parameterization
- Consistent device information

Best in Class:

Compact, precise and faster

The optoNCDT 1220 laser sensors are among the best in their class. They offer a unique combination of speed, size and performance. These laser sensors are used for the precise measurement of displacement, distance and position in all fields of automation technology, such as machine building, 3D printers and robotics.

The optoNCDT 1220 sensors use intelligent surface control. Auto Surface Compensation (ASC) enables stable measurement results, even if the target surface changes color or brightness.

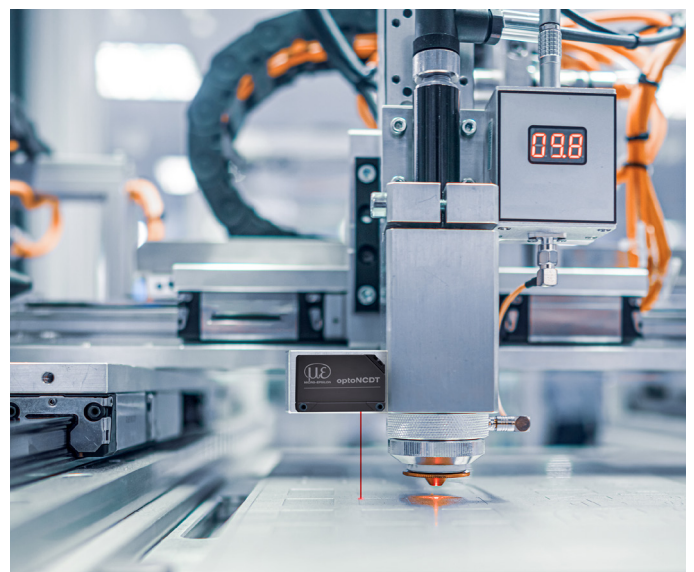

Model	ILD1220-10-IO-Link	ILD1220-25-IO-Link	ILD1220-50-IO-Link	ILD1220-100-IO-Link	ILD1220-200-IO-Link	ILD1220-500-IO-Link	
Measuring range	10 mm	25 mm	50 mm	100 mm	200 mm	500 mm	
Start of measuring range	20 mm	25 mm	35 mm	50 mm	60 mm	100 mm	
Mid of measuring range	25 mm	37.5 mm	60 mm	100 mm	160 mm	350 mm	
End of measuring range	30 mm	50 mm	85 mm	150 mm	260 mm	600 mm	
Measuring rate ^[1]	4 adjustable stages: 2 kHz / 1 kHz / 0.5 kHz / 0.25 kHz						
Linearity ^[2]	< ±10 μm	< ±25 μm	< ±50 μm	< ±100 μm	< ±200 μm	< ±750 μm ... 1500 μm	
	< ±0.10 % FSO					< ±0.15 % ... 0.30 % FSO	
Repeatability ^[3]	1 μm	2.5 μm	5 μm	10 μm	20 μm	50 μm	
Temperature stability ^[4]	±0.015 % FSO / K			±0.01 % FSO / K			
Light spot diameter ^[5]	SMR	90 x 120 μm	100 x 140 μm	90 x 120 μm	750 x 1100 μm	750 x 1100 μm	750 x 1100 μm
	MMR	45 x 40 μm	120 x 130 μm	230 x 240 μm			
	EMR	140 x 160 μm	390 x 500 μm	630 x 820 μm			
	smallest Ø	45 x 40 μm with 24 mm	55 x 50 μm with 31 mm	70 x 65 μm with 42 mm	-	-	-
Light source	Semiconductor laser < 1 mW, 670 nm (red)						
Laser class	Class 2 in accordance with IEC 60825-1: 2014						
Permissible ambient light ^[6]	20,000 lx				7,500 lx		
Supply voltage	11 ... 30 VDC						
Power consumption	< 2 W (24 V)						
Digital interface	IO-Link 1.1						
Connections	Power/signal: pigtail 0,3 m with M12 screw-in connector, 4-pin; A-coded						
Mounting	Screw connection via two mounting holes						
Temperature range	Storage	-20 ... +70 °C (non-condensing)					
	Operation	0 ... +50 °C (non-condensing)					
Shock (DIN EN 60068-2-6)	15 g / 6 ms in 3 axes, 1000 shocks each						
Vibration (DIN EN 60068-2-27)	20 g / 20 ... 500 Hz in 3 axes, 2 directions and 10 cycles each						
Protection class (DIN EN 60529)	IP67						
Material	Aluminum housing						
Weight	approx. 50 g (incl. pigtail)						
Control and indicator elements	Select button: zero, factory settings; 2 x color LEDs for power / status						

^[1] Factory setting 1 kHz

^[2] FSO = Full Scale Output; the specified data apply to white, diffuse reflecting surfaces (Micro-Epsilon reference ceramic for ILD sensors)

^[3] Measuring rate 1 kHz, median 9

^[4] Related to digital output in the mid of the measuring range; the specified value is only achieved by mounting on a metallic sensor holder. Good heat dissipation from the sensor to the holder must be ensured.

^[5] ± 10 %; SMR = Start of measuring range; MMR = Mid of measuring range; EMR = End of measuring range

^[6] Illuminant: light bulb

Dimensions

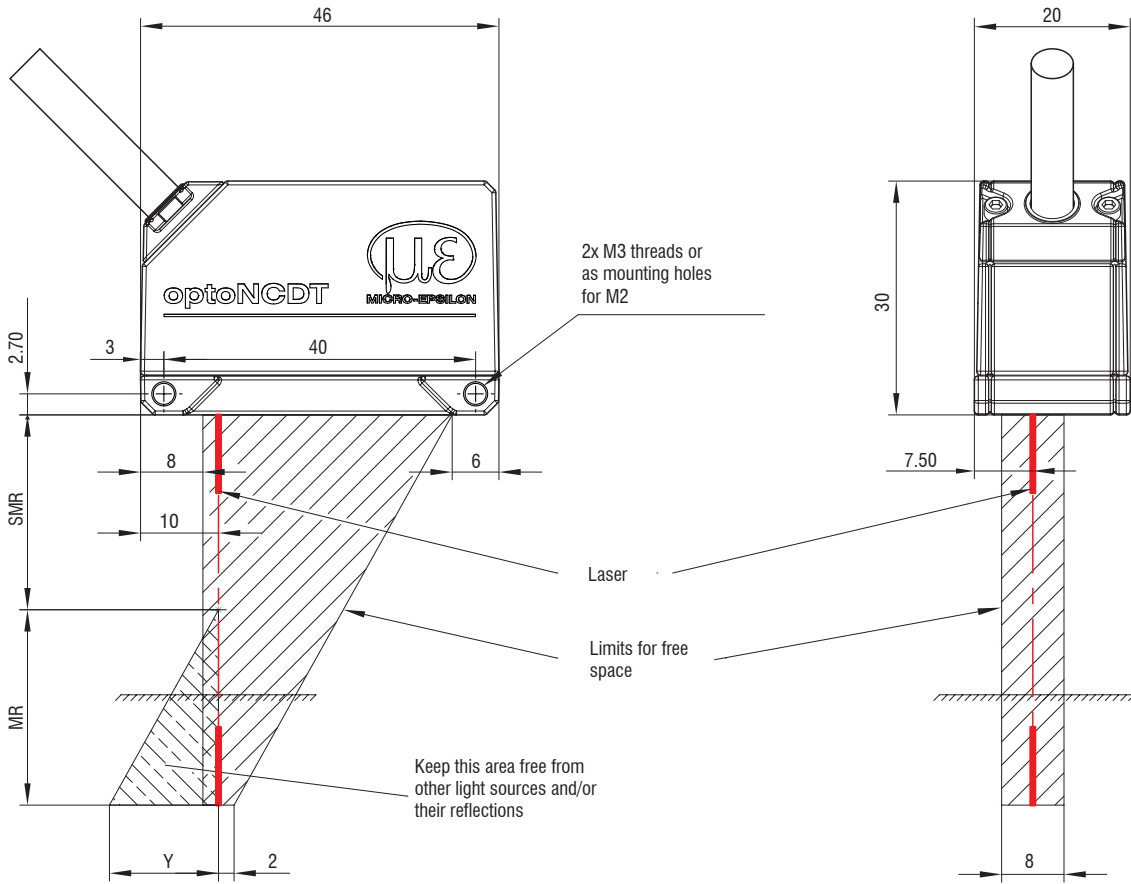

optoNCDT 1220

MR	SMR	Y
10	20	10
25	25	21
50	35	28
100	50	46
200	60	70
500	100	190

Connector (sensor side): pigtail 0.3 m

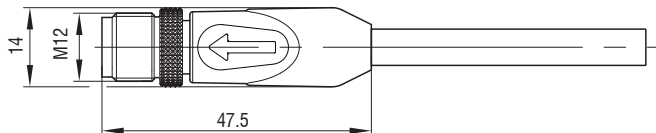

(dimensions in mm, not to scale)



MICRO-EPSILON Headquarters
 Koenigbacher Str. 15 · 94496 Ortenburg / Germany
 Tel. +49 (0) 8542 / 168-0 · Fax +49 (0) 8542 / 168-90
 info@micro-epsilon.com · www.micro-epsilon.com