

Warnings

Connect the power supply according to the safety regulations for electrical equipment.

- > Risk of injury
- > Damage to or destruction of the sensor

The supply voltage must not exceed the specified limits. Avoid shocks and impacts to the sensor. Do not bend or cant the sensor rod and the measuring tube.

- Do not carry the sensor on the sensor rod.
- > Damage to or destruction of the sensor

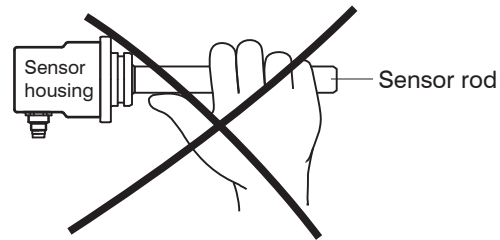

Notes on CE Marking

The following apply to induSENSOR EDS eddy current long-stroke displacement sensors with current output:

- EU Directive 2014/30/EU
- EU Directive 2011/65/EU

The sensor satisfies the requirements if the guidelines in the operating instructions are maintained in installation and operation.

Pin Assignment for Power Supply and Analog Output

The 7-pin connector on the sensor housing ensures power supply and signal output.

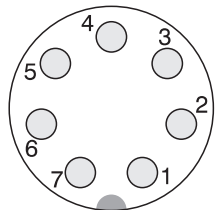

View on solder pin side

7-pole M9 cable connector (Binder, type 702)

Pin	Assignment	Color (cable: C703-x) ¹
1	Supply + (18 ... 30 VDC)	White
2	0 V ground	Brown
3	I_{OUT} 4 ... 20 mA ²	Green
4	Signal ground	Yellow
5	Assigned internally	Gray
6	Assigned internally	Pink
7	Not assigned	Blue

Pin assignment for power supply and analog output

Pin 2 and pin 4 are connected internally on the sensor electronics. The shield of the sensor cable is connected to the housing of the cable socket.

- ➡ Connect the shield of the sensor cable with the protective ground on the supply side.

- 1) The C703-5 sensor cable is available as an optional accessory, see Appendix of the Operating Instructions.
- 2) Output voltage of 1 ... 5 V with the C703-5/U.

Proper Environment

- Protection class:
 - Front side: 450 bar
 - Rear side: ¹ IP67
- Temperature range:
 - Storage: -40 ... +100 °C (-40 ... +212 °F)
 - Operation: -40 ... +85 °C (-40 ... +185 °F)
- Humidity: 5 - 95 % (non-condensing)
- Ambient pressure: 450 bar (front side)

- 1) Models with plug connection only with suitable and connected mating plug

Scope of Supply

- 1 Eddy current long-stroke displacement sensor
- 1 Measuring tube
- 1 O-ring (mounted on sensor)
- 1 Test report
- 1 Assembly Instructions

You can find more information about the sensor in the operating instructions. They are available online at:

<https://www.micro-epsilon.com/download-file/man--induSENSOR-EDS--en.pdf>

Measuring Principle

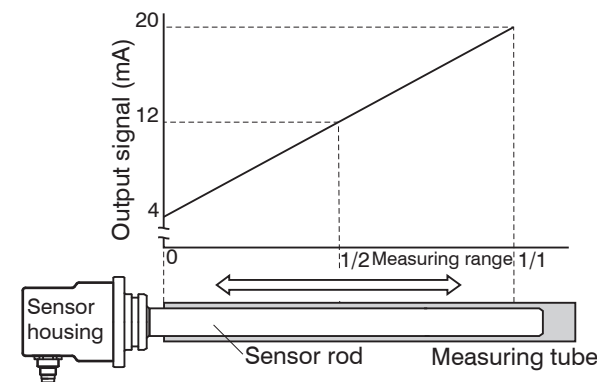

Output characteristic of an eddy current long-stroke displacement sensor.

Position of measuring tube: Start of measuring range

MICRO-EPSILON MESSTECHNIK GmbH & Co. KG
Koenigbacher Str. 15
94496 Ortenburg / Germany
Tel. +49 8542 / 168-0 / Fax +49 8542 / 168-90
e-mail info@micro-epsilon.com
www.micro-epsilon.com

Your local contact: www.micro-epsilon.com/contact/worldwide/

X9771051.01-B012051HDR



Assembly Instructions
induSENSOR
EDS- ... -S Series



Installation and Assembly

Precautions

- The measuring tube must not contact the sensor rod during operation.
- > Damage to or destruction of the sensor through abrasion is possible.
 - Do not deform or shorten the measuring tube.
 - > Loss of specified technical data
 - Do not crush the O-ring or damage through sharp-edged items.
 - > Loss of functionality

Sensor Mounting

- ➔ Mount the sensor on the cylinder with mounting ring ¹ and 6 cylinder head screws (M5 x 10).

Sealing is provided by a supplied O-ring on the sensor shaft.

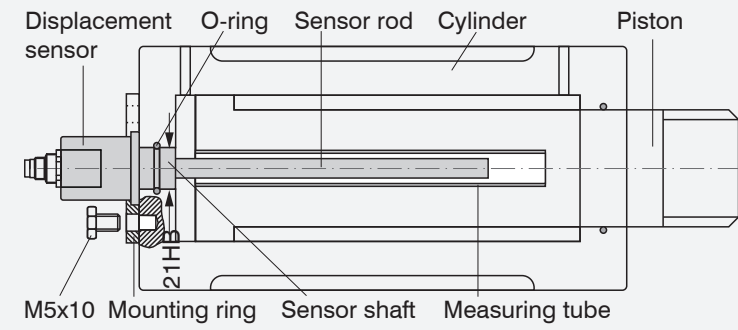

Sensor mounting in a hydraulic cylinder

Dimension	Tolerance
Pressure chamber seal:	Mounting hole for flange: Ø21H8
- O-ring: 18.5 x 1.5	Borehole surface:
- Material: Viton	- $R_a = 0.8$
	- $R_{max} = 3.2$

- 1) The mounting ring is available as an optional accessory, see Operating Instructions, chapter Optional Accessories

Measuring Tube Guidance and Fastening

- ➔ Mount the measuring tube flush in the piston bore.

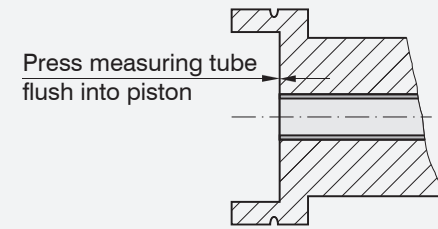

The dimensions for the measuring tube can be found in the adjacent dimensional drawings. The measuring tube must not touch the sensor shaft when the piston is retracted.

Note the measuring tube position at zero point (= 4 mA output).

- > Improper measuring tube guidance can lead to increased wear and premature failure.

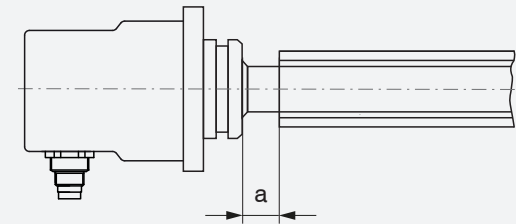

Zero position of the measuring tube

Measuring range	75	100	160	200	250	300	400	500	630
Dimension a	15	20	20	20	20	20	25	25	25
	(0.59)	(0.79)	(0.79)	(0.79)	(0.79)	(0.79)	(0.98)	(0.98)	(0.98)

A slightly eccentric mounting of the measuring tube has no negative influence on the sensor signal.

- ➔ Mount the measuring tube in the piston by means of pressing or gluing.

Spot clamping is not permissible.

The specified technical data only apply when the measuring tube supplied by MICRO-EPSILON is used!

- ➔ Use a suitable tool for mounting.

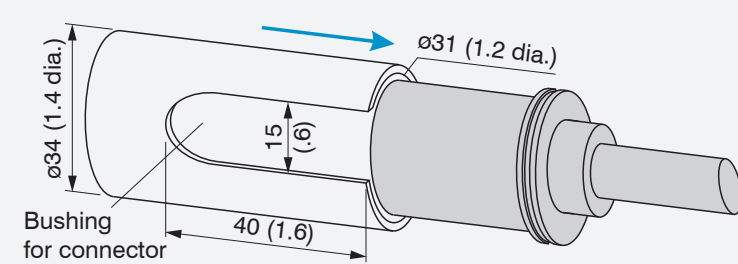

Mounting of an induSENSOR, EDS- ... -S series

The bushing must be congruent with the connector for models with radial connector.

Dimensions in mm (inches)

Dismantling

- ➔ Use a suitable extractor for dismantling.

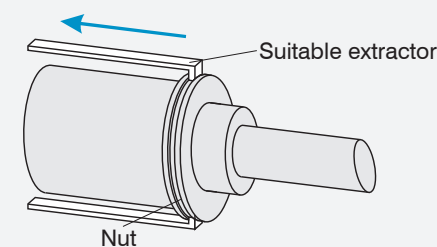

Dismantling an induSENSOR, EDS- ... -S series

Dimensions of the flange groove:

1.5 x 1.5 mm (depth x width)

Dimensional Drawings

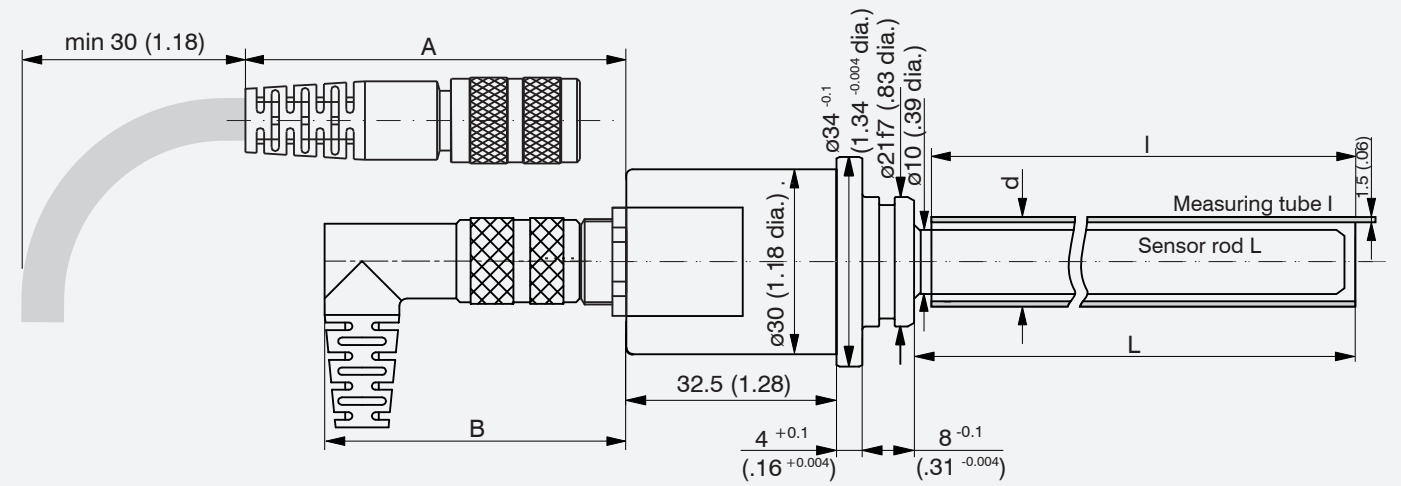

induSENSOR with axial connector, EDS- ... -SA7 - I series, measuring range: 75 / 100 / 160 / 200 / 250 / 300, dimensions in mm (inches)

Dimension	Tolerance μm		A	B
21f7	-20	EDS-xxx-S-Sx-I ¹	31 (1.2)	16 (.63)
	-41	EDS-xxx-S-Sx7-I ¹	51 (2.0)	47 (1.85)

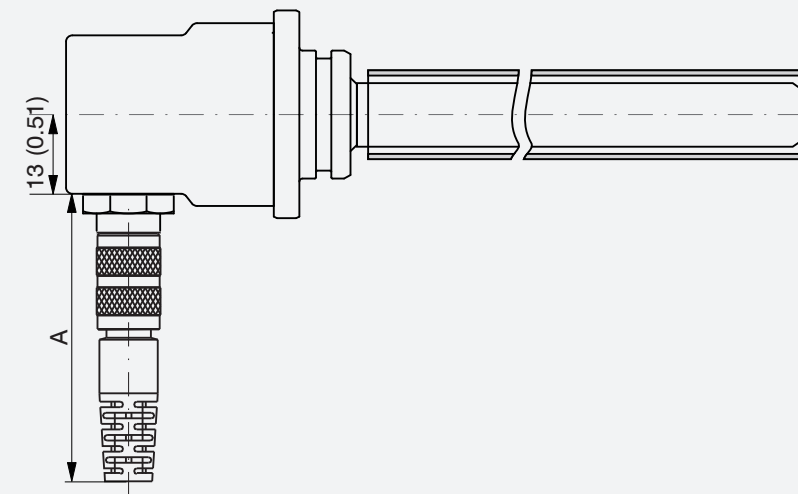

induSENSOR with radial connector, EDS- ... -SR7 - I series, measuring range: 75 / 100 / 160 / 200 / 250 / 300, dimensions in mm (inches)

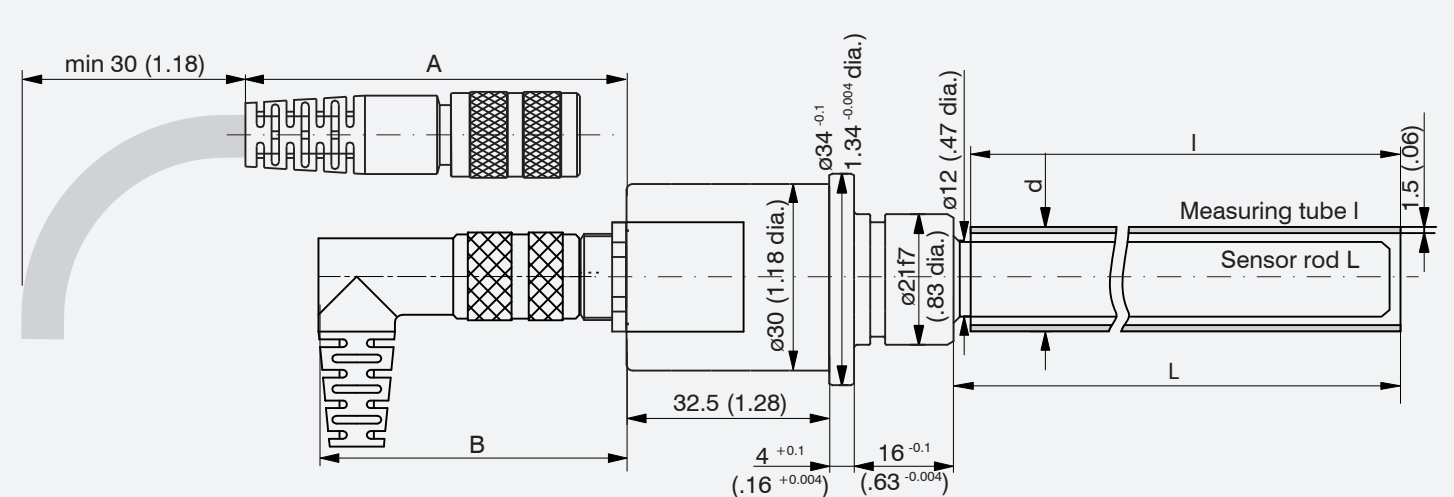

induSENSOR with axial connector, EDS- ... -SA7 - I series, measuring range: 400 / 500 / 630, dimensions in mm (inches)

Dimension	Tolerance μm		A	B
21f7	-20	EDS-xxx-S-Sx-I ¹	31 (2.19)	16 (.63)
	-41	EDS-xxx-S-Sx7-I ¹	51 (2.1)	47 (1.85)

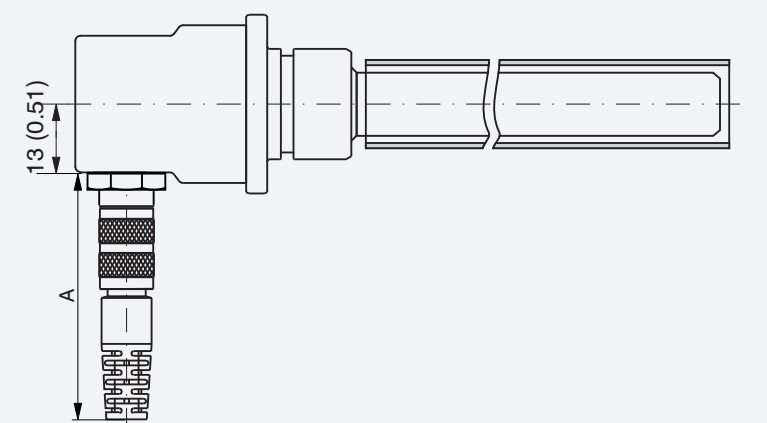

induSENSOR with radial connector, EDS- ... -SR7 - I series, measuring range: 400 / 500 / 630, dimensions in mm (inches)

Measuring range	Sensor rod L	Measuring tube l	Measuring tube d
75 (2.95)	110 (4.33)	110 (4.33)	16 (.63)
100 (3.94)	140 (5.51)	140 (5.51)	16 (.63)
160 (6.29)	200 (7.87)	200 (7.87)	16 (.63)
200 (7.87)	240 (9.45)	240 (9.45)	16 (.63)
250 (9.84)	290 (11.42)	290 (11.42)	16 (.63)
300 (11.81)	340 (13.39)	340 (13.39)	16 (.63)
400 (15.74)	450 (17.72)	450 (17.72)	18 (.71)
500 (19.69)	550 (21.65)	550 (21.65)	18 (.71)
630 (24.80)	680 (26.77)	680 (26.77)	18 (.71)

1) Previous model no longer available