

LASER PROFILING

**NEW**  
**scanCONTROL 2800**

Very high-speed  
profile measurement for  
industrial in line applications.



**High accuracy and  
very high frame frequency**  
thanks to

- **innovative  
CMOS-technology**
- **high-performance  
signal processing unit**
- **flexible field of view**

2D/3D profile sensor  
**scanCONTROL 2800**

## 2D/3D Laser-Line Triangulation

### Measuring principle

The laser-line profile sensor scanCONTROL 2800 makes use of the triangulation principle for two-dimensional acquisition of profiles on the most varied target surfaces.

In contrast to familiar point laser sensors, a line optical system projects a laser line onto the surface of the object to be measured. The back scattered light from the laser line is registered on a CMOS array by a high quality optical system. Along with distance information (z-axis), the controller also computes the true position along the laser line (x-axis) from the camera image and outputs both values in the sensor two-dimensional coordinate system.

A moving object or a scanning sensor will generate a three-dimensional representation of the object.

### System configuration

scanCONTROL consists of a compact sensor and an intelligent controller connected together via cable of variable length. The controller outputs measurement raw data computed from both axes (standard) as well as related values of geometrical features (optional).

Thanks to its exceptional speed of measuring and real time data output synchronisation scanCONTROL is not limited in its applications and is ideally suited for industrial in line inspection. The integrated FireWire interface enables scanCONTROL to be fully controlled from a PC, while insuring high data output rates and simultaneously preserving the bandwidth. Integrated via a PCI card in the bus system, FireWire also facilitates control of several scanCONTROL systems from one PC.

### Measuring principle

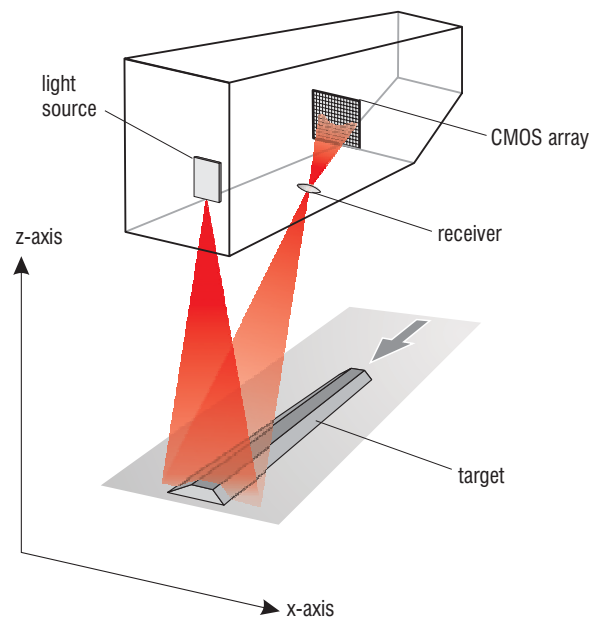

Sensor LLT 2800



Controller LLT 2800

### Three ways of creating the application:

- PC solutions with the customer's own software (C++ library included in supplied items).
- PC solutions with the ICONNECT modular software with ready-made standard modules for control and evaluation.
- Integrated software packages (optional) in the digital signal processor (DSP) of the controller.

### Special performance features

scanCONTROL has been developed for industrial applications. In this respect, innovative technologies are employed through which the functionality of the system and adaptability to different applications are substantially increased.

### Synchronous measurement through synchronous illumination

scanCONTROL uses an innovative CMOS array with a global, electronic shutter (high speed shutter) instead of a "rolling shutter" used in conventional scanners.

Measurement therefore occurs synchronously along the laser line, thus eliminating any distortion of the measurement image due to scanning.

The shutter can in addition be controlled in real time via an external trigger input (on the controller). The additional trigger input eases synchronizing several scanCONTROL systems together.

The real time shutter renders the measurement system nearly independent of scanning or object displacement speed and acceleration. This is an important advantage in achieving short throughput times, particularly in automation where varying acceleration levels often occur in processes.

### Innovative high performance CMOS array

A specially developed high performance CMOS array supports the illumination of the next image while the current image is still being read out. This means that for the same laser class higher measuring frequencies are achieved even with shiny or strongly absorbing surfaces.

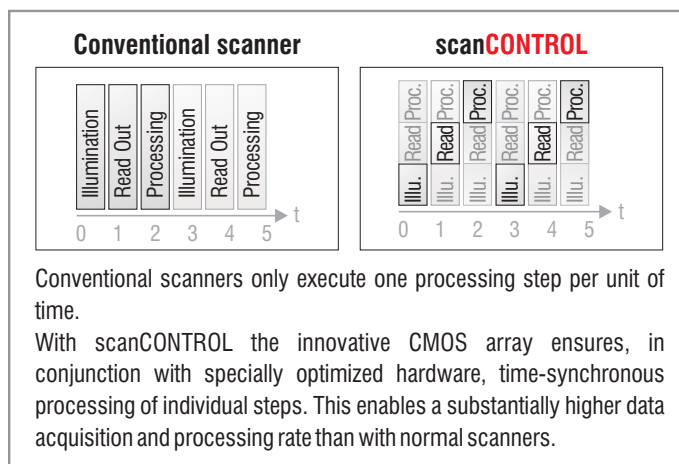

### Flexible measuring field

According to application, user may parameter the sensor privileging either data acquisition speed or width and/or depth of measuring field. The sole limit is acquisition of a max. of 256,000 points/sec eg.: user can elect to measure

- 256 points/profile:** at profile frequency of **1000 profiles/sec**
- 512 points/profile:** at profile frequency of **500 profiles/sec**
- 1024 points/profile:** at profile frequency of **250 profiles/sec**

On top of speed and number of points selection, user can also decide width of profile line and depth of measuring field eg.: 512 points over a narrow profile thus increasing lateral resolution (for edge detection) or 256 points over a large profile to increase digitising speed (typical for large surface inspection) or any other combination among 96 possible.

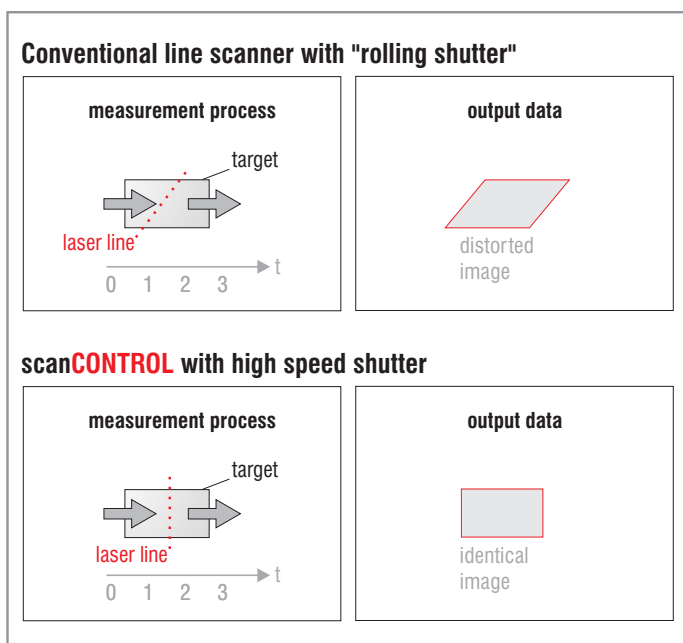
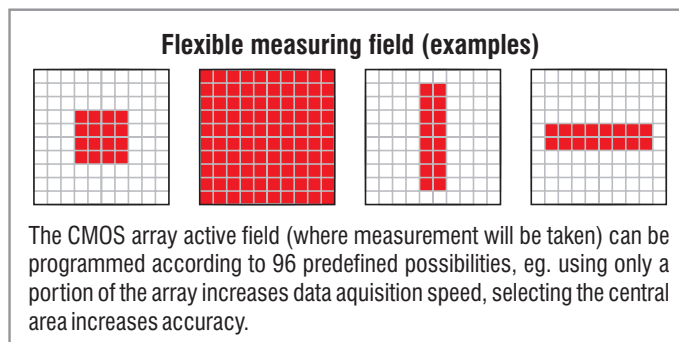

Typical Applications

Applications

scanCONTROL 2800 is designed for applications in industrial environments. High measuring rate and accuracy make the system ideally suited for applications requiring highest precision with short cycle times.

scanCONTROL and ICONNECT

The link between the FireWire high speed interface and the MICRO-EPSILON real-time software ICONNECT opens up an unlimited number of possible applications for scanCONTROL. Using the graphic user interface in ICONNECT, it is very easy for user to generate applications of their own. The modular programming principle allows complex links to be produced with just a mouse click. The real-time capability and high data throughput of ICONNECT supplement and support the high processing speed of scanCONTROL. Data are recorded, processed and visually displayed in real time, even at the highest scanning rate. ICONNECT can also be used as the real time control software and then acts as a line PLC.

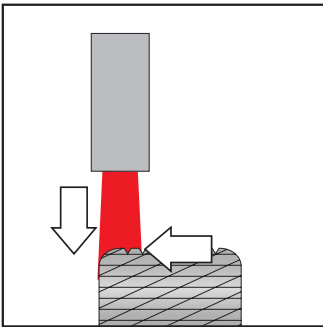

Tire profile  
Tire roundness  
Tire deformation

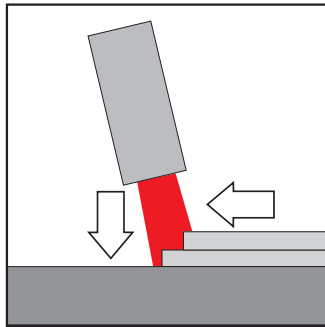

Edge detection  
Positioning  
Height profile

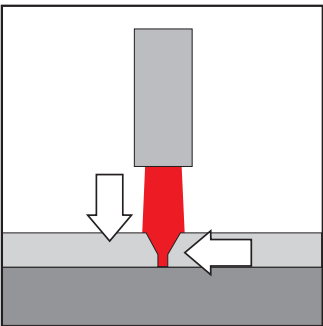

Groove width and depth  
Robot guidance

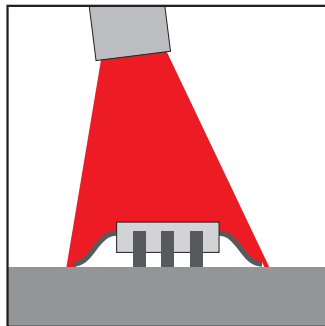

Coplanarity  
Deformation  
Lead position

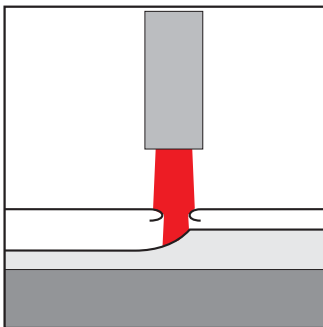

Gap and flush  
Door edges

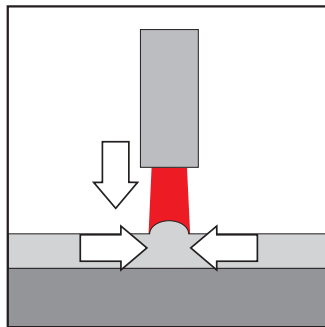

Welding seam inspection  
Glue bead inspection  
Profile monitoring

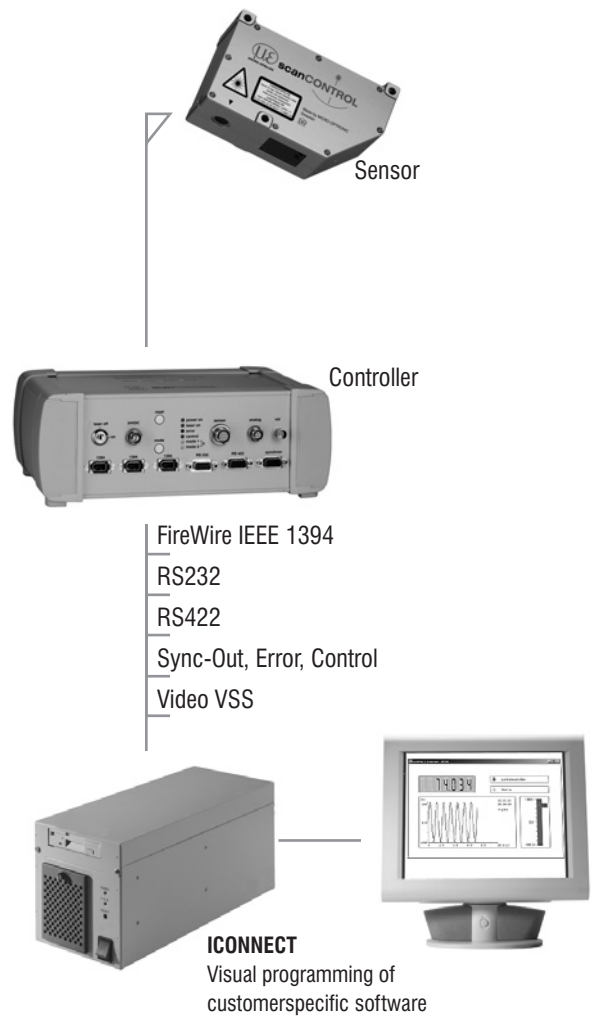

Model	LLT2800-25		LLT2800-100		
<b>Standard ranges, extended range in brackets (±5%)</b>					
Measuring range z-axis	25 (55) mm	0.98" (2.17")	100 (245) mm	3.94" (9.65")	
Start of measuring range (SMR)	62.5 (50) mm	2.46" (1.96")	145 (115) mm	5.71" (4.53")	
Reference distance, midrange (MMR)	75 (82.5) mm	2.95" (3.25")	195 (235) mm	7.68" (9.25")	
End of measuring range (EMR)	87.5 (105) mm	3.44" (4.13")	245 (360) mm	9.65" (14.17")	
Resolution z-axis *	0.04%				
	10 µm		40 µm		
Linearity z-axis, ±3σ <sup>‡</sup>	±0.2 %				
	±50 µm		±200 µm		
Measuring range x-axis	SMR	13 (23) mm	0.51" (0.91")	30 (50) mm	1.18" (1.97")
	EMR	18 (41) mm	0.70" (1.61")	50 (140) mm	1.97" (5.51")
Laser aperture angle	30 °				
<b>Resolution x-axis</b>	<b>256 / 512 points/profile (1024 points/profile)****</b>				
Linearity x-axis, ±3σ <sup>‡</sup>	±0.4 %				
	SMR 60 µm / EMR 80 µm		SMR 120 µm / EMR 200 µm		
<b>Profile frequency</b>	<b>to 1000 profiles/s</b>				
<b>Measuring rate</b>	<b>256,000 points/s</b>				
Light source	laser diode 655 nm, 15 mW				
Laser class	class 2M				
Laser off	remote - input and key switch				
Permissible ambient light (fluorescent light)	10,000 lx				
Protection class	sensor	IP 64			
	controller	IP 40			
Operating temperature	0...50 °C / 32...122 °F				
Storage temperature	-20...70 °C / -4...158 °F				
Weight	sensor	350 g	400 g		
	controller	3.5 kg			
Sensor cable standard length	2 m				
<b>Output analog</b>					
preprogrammed x- and z-axis, alternative profile parameter **	±10 V (16 bit, up to 150 kHz)				
<b>Output/Input digital</b>					
Interface (measurement data and control commands)	3x IEEE 1394 („FireWire“), 400 MBit/s (similar DCAM 1.30)				
	1x RS232 (115200 Baud)				
	1x RS422 (115200 Baud)				
Synchron-connector, input ***	sync-in, remote laser ON/OFF, mode				
Synchron-connector, output ***	sync-out, error, user mode (2x)				
Video signal (test and set up mode)	1 V <sub>SS</sub> (BAS-signal, 8-bit-grey)				
Supply	24 VDC (±15 %) / 0.5 A				

! All specifications apply for a diffusely reflecting matt white ceramic target - marginal position tolerance of the measuring-field is possible (sensor depending) SMR = Start Measuring Range EMR = End of Measuring Range

\* for standard measuring ranges (512 points/profile preprogrammed)

\*\* only for preprogrammed data, e.g. gap edge position, gap width, step height, angle

\*\*\* preprogrammed, other function possible

\*\*\*\* optional 1024 points/profile only in extended range

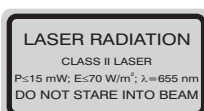

The laser unit of scanCONTROL 2800 uses a semiconductor laser with a wavelength of 655 nm (visible/red) and 15 mW optical output (class 2M). The sensor is classified as laser class 2M. A warning sign is attached to the sensor housing.

**scanCONTROL 2800-25** Dimensions in mm (inch), not to scale

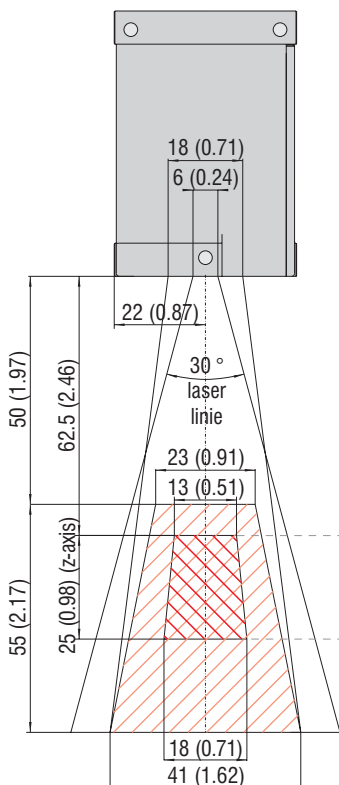
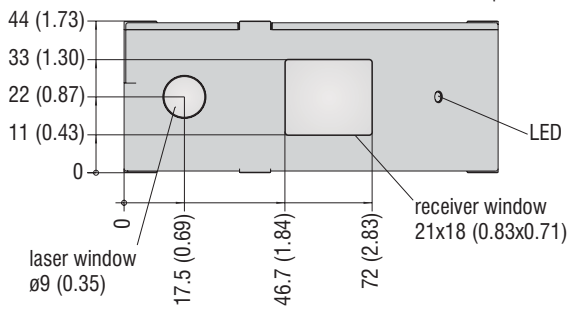
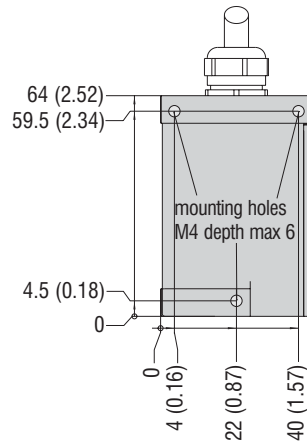
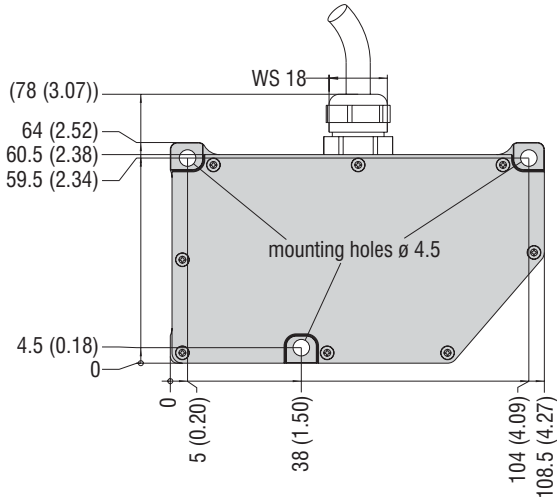

- standard measuring range
- extended measuring range

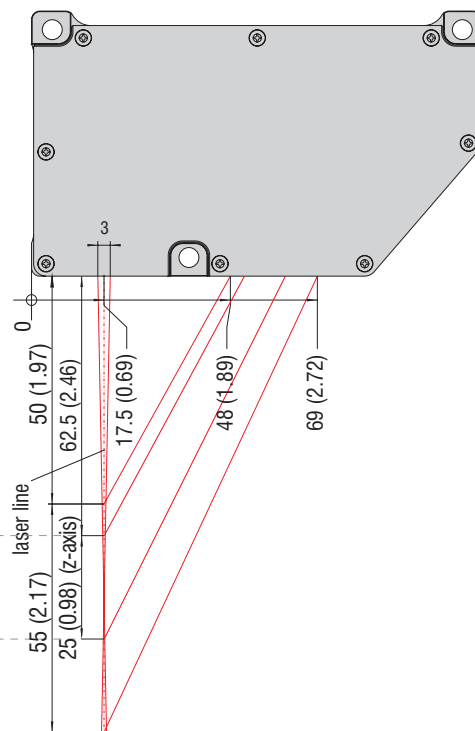

Marginal position tolerance of the measuring-field is possible (sensor depending)

# Sensor Dimensions

## scanCONTROL 2800-100 Dimensions in mm (inch), not to scale

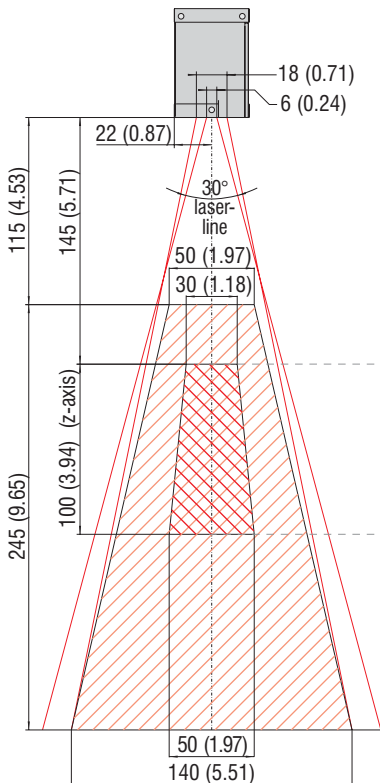
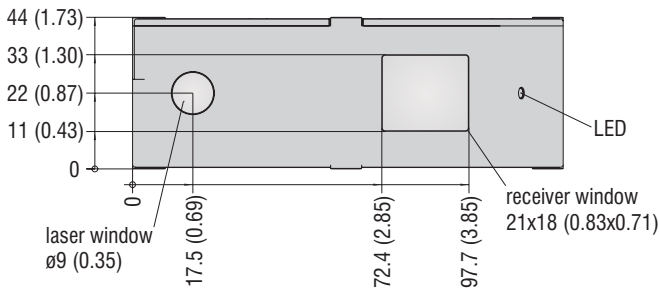
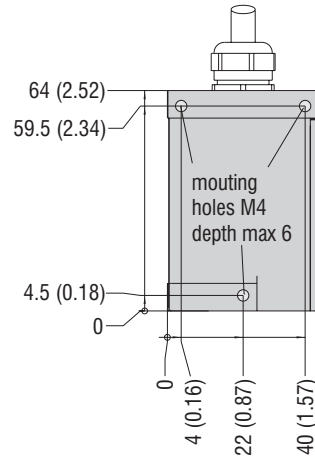
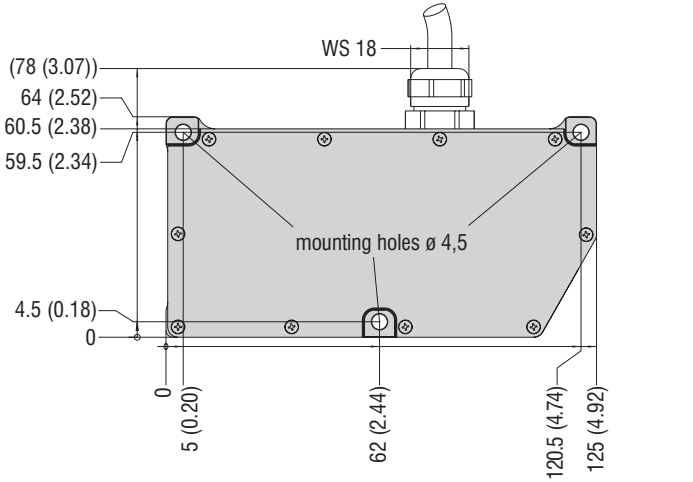

- standard measuring range
- extended measuring range

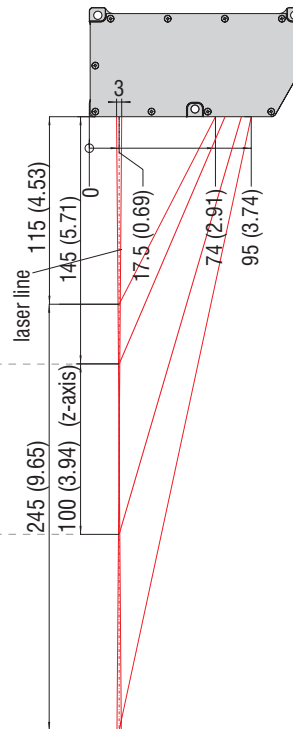

Marginal position tolerance of the measuring-field is possible (sensor depending)

# scanCONTROL 2800 Controller

Dimensions in mm (inch), not to scale

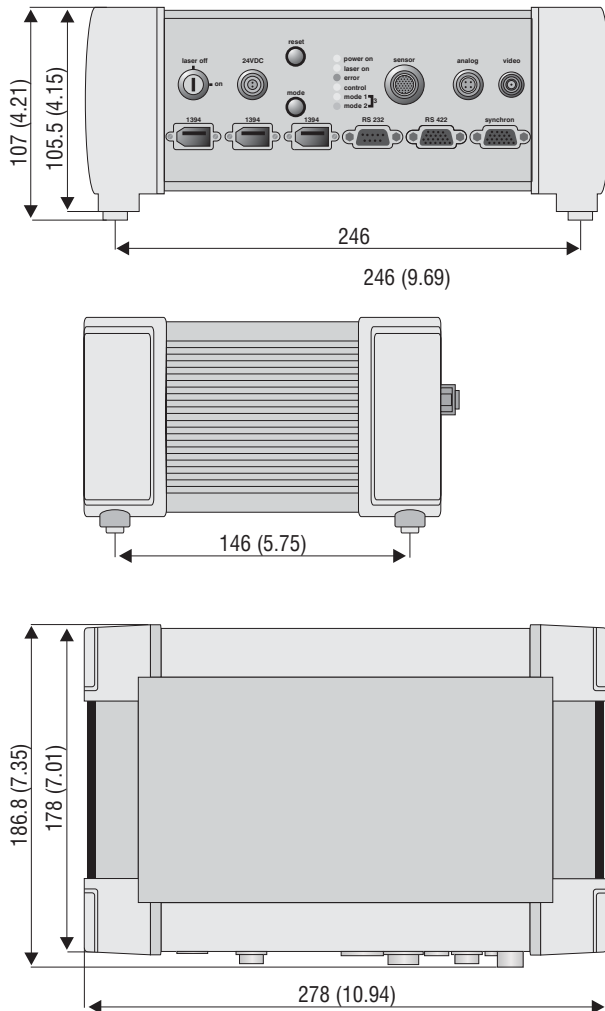

## Typical system includes (standard)

- ICONNECT-demonstration software (FireWire interface)
- Stand alone demo-software (standard FireWire or serial interface RS232)
- C++ library for customer-specific application
- IEEE 1394 cable
- Calibration certificate

## Accessories (optional)

- Sensor extension cable 3 m or 8 m
- Cable analog output
- Interface card IEEE 1394
- ICONNECT modular software

## MICRO-EPSILON

info@micro-epsilon.com  
www.micro-epsilon.com

info@micro-epsilon.co.uk  
www.micro-epsilon.co.uk

info@micro-epsilon.us  
www.micro-epsilon.us

certified DIN EN ISO 9001 : 2000  
modifications reserved / Y9761137-B030027JKR

