

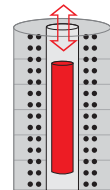

# More Precision.

**indu**SENSOR

Linear inductive displacement sensors



## Series LVP DC: Inductive sensors with measuring plunger and integrated electronics

- No wear and no maintenance
- Integrated microelectronics
- Compact design - short installed length
- Shielded against EMI
- For use in difficult ambient conditions

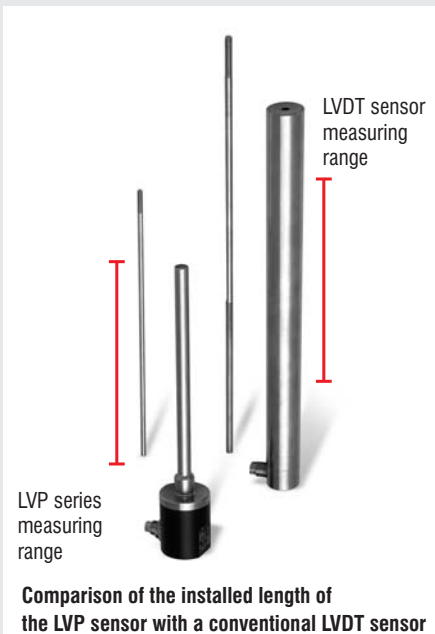

### Comparison of the installed length of the LVP sensor with a conventional LVDT sensor

An important advantage of the LVP measuring technique lies in the short length of the installed sensor. This difference in lengths becomes clear in a direct comparison with an LVDT sensor.

LVP series housing version -ZA-

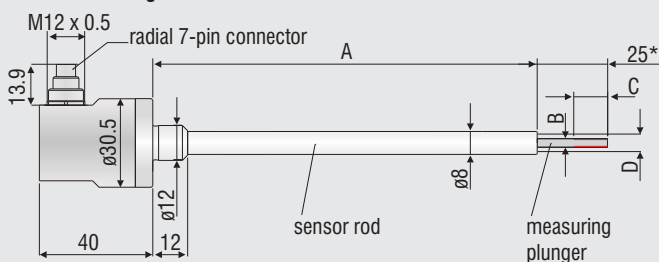

\* measuring plunger start position  $I_{out} = 4 \text{ mA}$

Measuring range	A	B	C	D
50	77	M2	10	4
100	138	M3	12	4
200	261	M3	12	4

All data in mm

Model		LVP-50	LVP-100	LVP-200
Measuring range		50 mm	100 mm	200 mm
Linearity	standard $\pm 0.5\%$ FSO	0.25 mm	0.5 mm	1.0 mm
	option $\pm 0.25\%$ FSO	0.125 mm	0.25 mm	-
Resolution	$< 0.03\%$ FSO	0.015 mm	0.03 mm	0.06 mm
Temperature range		$-40\text{ }^{\circ}\text{C} \dots +85\text{ }^{\circ}\text{C}$		
Temperature stability	zero	$\pm 50\text{ ppm} / ^{\circ}\text{C}$		
	sensitivity	$\pm 150\text{ ppm} / ^{\circ}\text{C}$		
Frequency response (-3 dB)		300 Hz		
Output		4 - 20 mA		
Output load		500 Ohm		
Power supply		18 - 30 VDC		
Current consumption		max. 40 mA		
Protection class		IP 67		
Electromagnetic compatibility (EMC)		EN 50 081-2 spurious emission EN 50 082-2 interference immunity		
Shock <sup>1</sup>	IEC 68-2-29	40 g, 3000 shocks / axis; 100 g radial, 300 g axial		
	IEC 68-2-27			
Vibration	IEC 68-2-6	5 Hz ... 44 Hz $\pm 2.5\text{ mm}$ ; 44 Hz ... 500 Hz $\pm 20\text{ g}$		

FSO = Full Scale Output

1) Half sinusoid 6 ms

## Article

LVP - 50 - ZA - 2.5 - SR7 - I

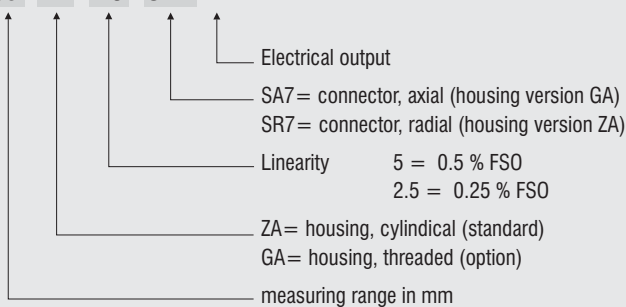

## LVP series housing version -GA- (option)

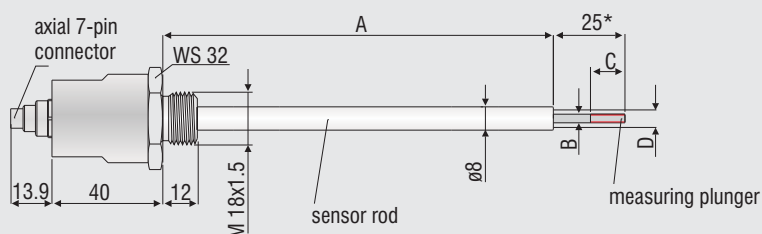

\* measuring plunger start position  $I_{out} = 4\text{ mA}$

## Sensor system with on-board electronics LVP-0,3-Z20-2-CR-AC

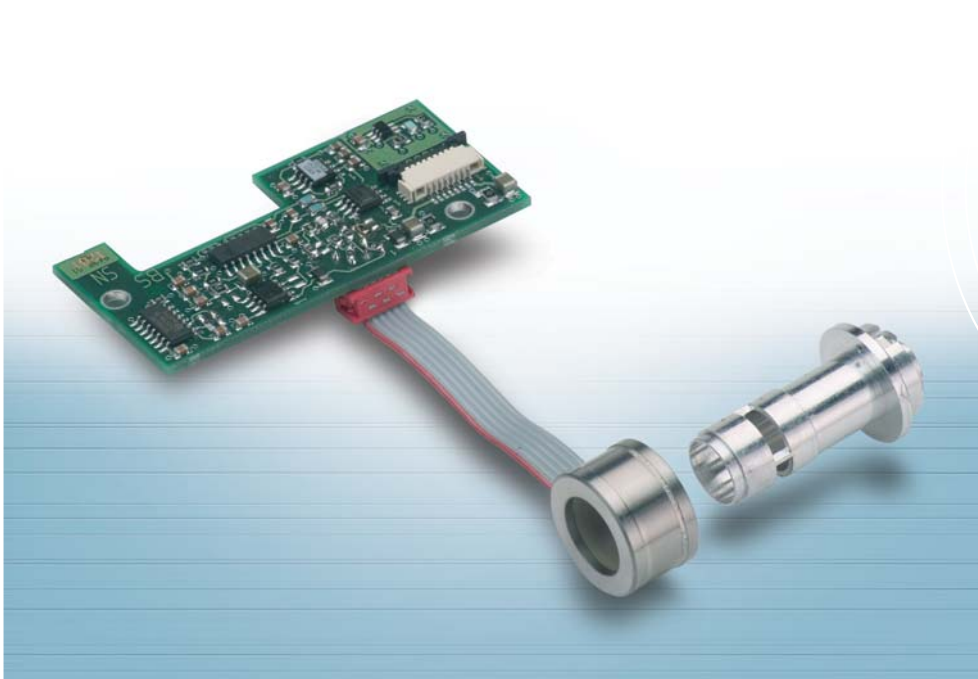

**Excellent ratio of installed length to measurement range**

**On-board electronics**

**Rugged and wear-free**

**High dynamic**

**Functional target**

Voice coil actuators are used for positioning with small displacements, with a high dynamic response, high repeatability and positioning accuracy as well as with strong accelerations. In conjunction with a servo system the voice coil actuator and the displacement sensor are operated in a closed circuit. These systems are used in applications in the optical industry, such as for optical scanning, focusing, tracking and stabilizing. Through the use of the sensor the optical beam path and the mechanical system can be set up on one axis. The optical path is combined with the line of center of gravity for the motor and the measurement object.

This produces a simpler mechanical construction, higher stability and a smaller installation space.

Model	LVP-0,3-Z20-2-CR-AC	
Article	2617009	
Measuring principle	LVP (page 10-11)	
Measuring range	0.3 mm	
Target	customer specific, not included	
Linearity	0.25 % FSO (0.75 $\mu\text{m}$ )	
Resolution	0.025 % FSO (0.1 $\mu\text{m}$ )	
Frequency response	3 kHz	
Housing	stainless steel	
Temperature stability	$\pm 200$ ppm / $^{\circ}\text{C}$	
Output	digital, TTL	
Power supply	+ 3.3 VDC	
Temperature range	sensor	-10 $^{\circ}\text{C}$ ... +40 $^{\circ}\text{C}$
	electronics	-10 $^{\circ}\text{C}$ ... +65 $^{\circ}\text{C}$
Protection class	IP 65	
Electronics	including PCB electronics 4111006.03, MSC739/CRF-AD	

FSO = Full Scale Output

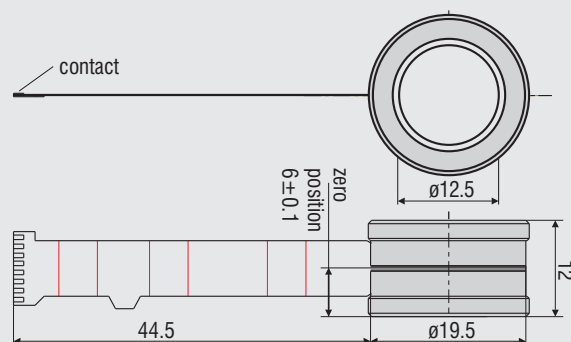
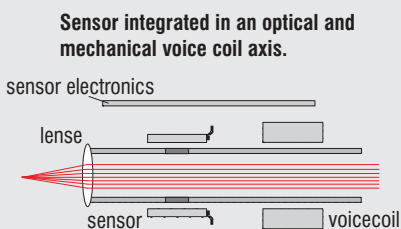

## Sensor module with ASIC electronics LVPxx-P-LP-I/D



### Market leading technology

Stroke measurement in hydraulic and solenoid valves

Measurement ranges from 1 to 10 mm with only one sensor module

Customer specific target

Model	LVPxx-P-LP-I/D				
Article	2616079				
Measuring principle	LVP (page 10-11)				
Measuring range	±1 mm	±2 mm	±3 mm	±4 mm	±5 mm
Target, plunger length	10.5 mm	8.5 mm	8 mm	7 mm	5 mm
Linearity	0.2 % FSO			0.5 % FSO	1 % FSO
Resolution	2 μm	4 μm	6 μm	8 μm	10 μm
	10 bit				
Frequency response	200 Hz ... 1 kHz (-3dB)				
Temperature stability	± 100 ppm / °C (zero)				
	± 150 ppm / °C (sensitivity)				
Output	0.5 ... 4.5 VDC and 4 ... 20 mA				
	option: PWM, digital (serial)				
Power supply	+ 8 ... 35 VDC				
Temperature range	-40 °C ... +85 °C				
Storage temperature	-40 °C ... +100 °C				
Circuit dimensions	41 x 52 mm				
Alu tube dimensions	ø7 x 0.5 mm, 35 mm long				

FSO = Full Scale Output

The sensor system LVP-xx-P-LP-I/D is used as a testing system for the verification and inspection of the functionality of the system in electro-hydraulic servo valves.

The modular sensor construction facilitates a fast and simple adaptation to the specific application for use in large-scale production. The sensor and electronic system can be constructed as one unit or with a sensor cable. The LVP principle enables matching of the measurement ranges in a span from ±1 to ±5 mm by simply changing the target length.

The sensor element is mounted in the pressure-free space and is protected by a pressure pipe. The acquisition of the target position occurs through the pressure pipe.

## Sensor for needle stroke movements LVP-3-Z13-5-CA



### Compact design

Measurement object and sensor on one axis

No extension of the overall installed length due to sensor

<b>Model</b>	<b>LVP-3-Z13-CA</b>
Article	2617014
Measuring principle	LVP (page 10-11)
Measuring range	3 mm
Target (not included)	ø3 x 30 long with thread M3 and alu sleeve ø4 x 3.3
Linearity	typisch 0.3 % FSO (9 µm)
Housing	stainless steel
Temperature stability sensor	± 100 pmm / °C
Temperature range sensor	-40 °C ... +150 °C
Protection class sensor	IP 67
Electronics	series MSC7210
	series ISC7001

FSO = Full Scale Output

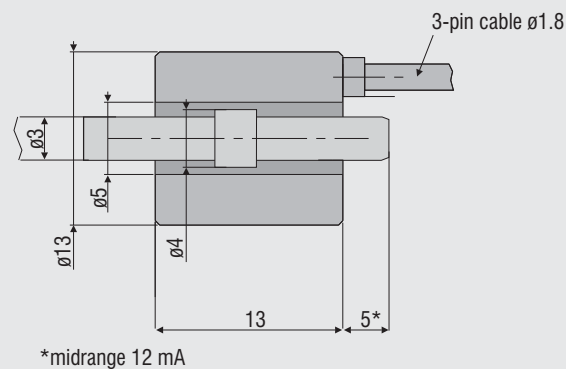

The compact displacement sensor LVP-3-Z13-5-CA is suitable for acquiring small measurement ranges with high accuracy. The large free hole for the passage of the core also facilitates large excessive strokes. The measurement object, realized as a simple aluminum ring, is mounted on the rod, plunger, pin, needle or other similar part to be measured. In a typical application the displacement sensor LVP-3-Z13-5-CA is used in automatic glue application guns. The continuously measuring sensor monitors the switching point, also for wear of the needle seating. Additionally, the continuous measurement offers the option of checking the needle for the correct stroke position. The small, compact sensor is easy to integrate even in tight installation spaces.

## Valve stroke sensor in stainless steel housing LVP-14-F-5-CR



**High temperature range**  
**Calibrated system with electronics**  
**High temperature stability**  
**Integrable sensor design, adaptable to large-scale production**  
**High cut-off frequency up to 20 kHz**

Future generations of engines will be able to dispense with mechanical camshafts. The displacement of the electromechanically or electrohydraulically driven inlet and outlet valves of internal combustion engines is acquired by the displacement sensor of the product line LVP-14-F-5-CR and fed into the control circuit. In this way a variable inlet and outlet control of the valves can be realized. Ultimately, the fuel consumption is reduced, emission values are improved and the engine power characteristic is matched to the individual driving situation.

Model	LVP-14-F-5-CR
Article	2616078
Measuring principle	LVP (page 10-11)
Measuring range	14 mm
Target	customer specific
Linearity	0.5 % FSO (0.07 mm)
Housing	stainless steel
Temperature stability sensor	$\pm 100$ pmm / °C
Temperature range sensor	-30 °C ... +150 °C
Protection class sensor	IP 67
Electronics	MSC739VS-U (article 4111009)

FSO = Full Scale Output

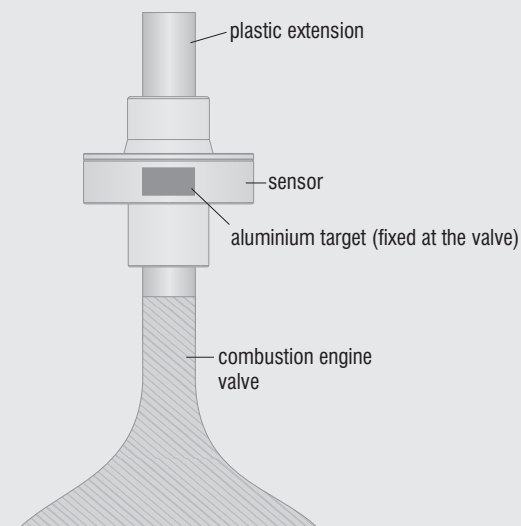
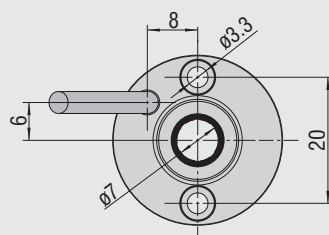
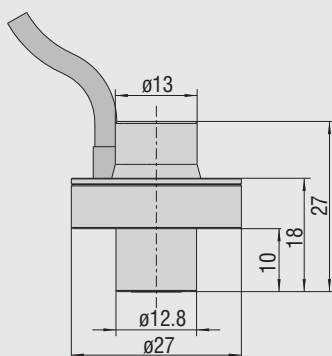

## Sensor for the acquisition of displacement on rotating shafts LVP-25-Z20-5-CA-AC



**Compact sensor for easy integration**  
**High resolution**  
**Shaft and sensor on one axis**  
**No extension of the overall installed length due to sensor**

With modern machine tools the critical moment is the change of tool. Deviations from the intended tool position can lead to severe cases of faulty production. Previously proximity sensors and connector rings were used for monitoring the clamped position, but they had to be adjusted and set, thereby incurring costs. Analog sensors from the series LVP offer a significant improvement. The sensor is integrated into the chuck and directly measures the clamping stroke of the drawbar. It can be universally used with the most varied types of tool due to an extremely compact design. The sensor supplies an analog signal according to the stroke motion of the drawbar when clamping the tool. Consequently, continuous monitoring is possible without the switching point having to be laboriously set mechanically.

The miniaturized sensor electronic unit is supplied with 24 VDC and can either be accommodated at the point of measurement or in the control cabinet. Due to its high accuracy, the sensor provides a significant contribution in satisfying the continually increasing demands on the precision and availability of machine tools.

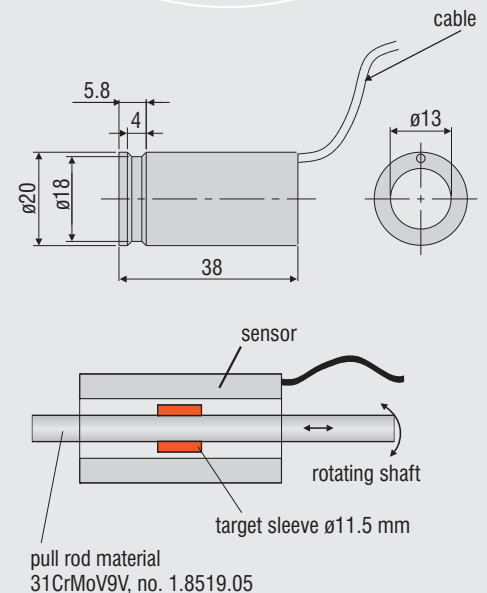

Model	LVP-25-Z20-5-CA-AC
Article	2617008
Measuring principle	LVP (page 10-11)
Measuring range	25 mm
Target (not included)	article 0482218 for shaft diameter 8 mm article 0482219 for shaft diameter 10 mm
Resolution	0.01 mm
Linearity	typical $\pm 1$ % FSO (0.25 mm)
Dynamics	150 Hz (-3dB)
Housing	stainless steel
Temperature stability sensor	$< \pm 0.01$ % FSO / °C
Temperature range sensor	-40 °C ... +150 °C
Protection class sensor	IP 67
Medium	air, oil
Electronics	MSC7210

FSO = Full Scale Output

# More Precision.

## [www.micro-epsilon.com](http://www.micro-epsilon.com)

### Sensors and systems

for displacement, position and dimension

### Sensors and measurement devices

for non-contact temperature measurement

### Measurement systems

for online/offline quality control

#### **MICRO-EPSILON Headquarters**

Koenigbacher Str. 15 · 94496 Ortenburg / Germany  
Tel. +49 (0) 8542 / 168-0 · Fax +49 (0) 8542 / 168-90  
[info@micro-epsilon.com](mailto:info@micro-epsilon.com)

#### **MICRO-EPSILON UK Ltd.**

Dorset House, West Derby Road · Liverpool, L6 4BR  
Phone +44 (0) 151 260 9800 · Fax +44 (0) 151 261 2480  
[info@micro-epsilon.co.uk](mailto:info@micro-epsilon.co.uk)



#### **MICRO-EPSILON USA**

8120 Brownleigh Dr. · Raleigh, NC 27617 / USA  
Phone +1/919/787-9707 · Fax +1/919/787-9706  
[info@micro-epsilon.us](mailto:info@micro-epsilon.us)