

**NEW: high temperature probe**  
**DZ135**

# APPLY TO TURBO SPEED

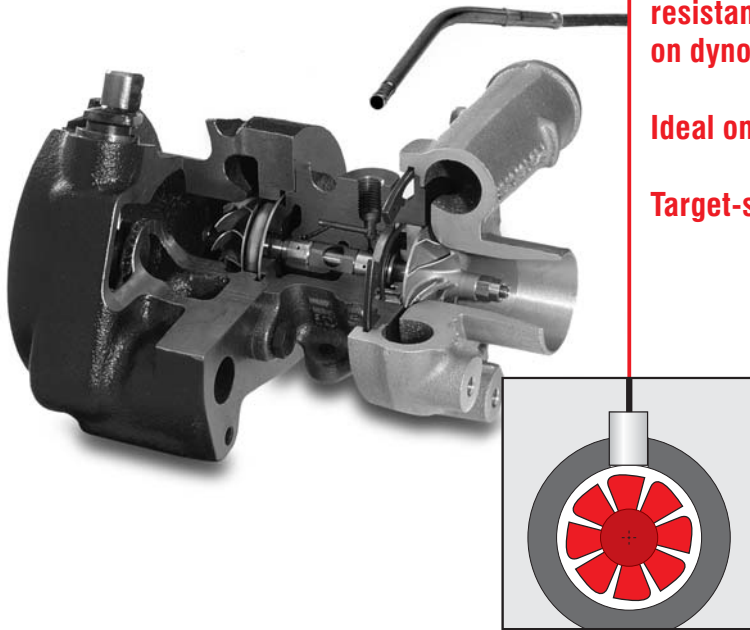

**Extreme high interference resistance and noise immunity on dyno and testbenches**

**Ideal on vehicle and test cell use**

**Target-sensor gap to 1.5 mm**

Speed Sensor for Turbo Chargers  
**turboSPEED 135**

## Speed Sensor for Turbo Chargers

### Measuring principle

A coil is potted in a sensor case and is energized by a high frequency alternating current. The electromagnetic field from the coil generates eddy currents in the turbo-charger blade. Every blade generates a pulse. The controller identifies the speed (analog 0 ... 10 V) by considering the number of blades.



### System properties

The DZ 135 marks the arrival of the next generation in eddy current turbocharger speed measurement systems. The primary aim of the further development was to produce a system immune to the most difficult EMC test cell conditions. Particularly where multi-test cells are in use, very high levels of EMC emissions are causing effect on test cell instrumentation. The DZ135 offers a new electronic circuit which 'boosts' signal levels from the sensor and also dramatically improves circuit shielding. This gives the sensor EMC levels of immunity which are several factors higher than existing devices in the marketplace. The system has also been designed to be able to replace the sensor mounted in the turbo housing, without having to recalibrate the system electronics.

The eddy current measurement technique is also immune to the effects of oil, dirt, carbon particles that can be found in the engine, which can affect the measurement output quality of other measurement principles, particularly capacitive and optical measurement technologies.

### ADVANTAGES:

- Maximum speed range from 500 to 400,000 RPM
- Miniature sensor design (ø 3 mm)
- No blade modification necessary
- Immune to electromagnetic interference
- Cable length to 25 m
- Supply 9 ... 30 VDC
- Target clearance up to 1.5 mm
- Changing sensor without calibration

### 1.) Operation with preamplifier

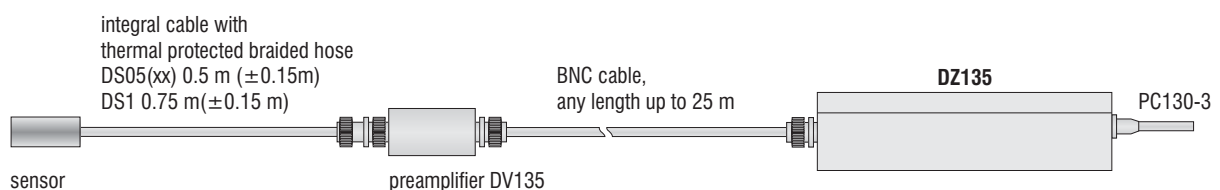

### 2.) Operation without preamplifier

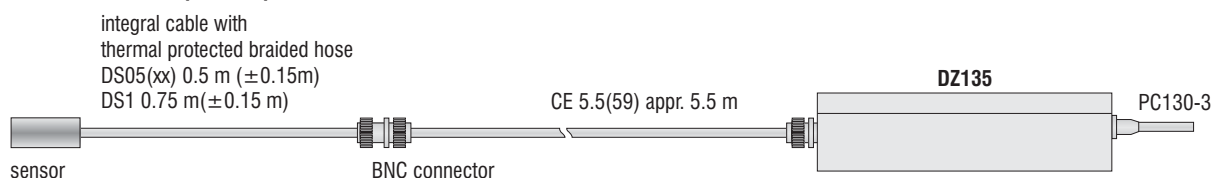

## Technical data



Controller DZ 135	DZ 135					
Amplifier (option)	DV 135					
Sensors	DS 05(03)	DS 05(04)	DS 05(07)	DS 05(14)	DS 05(15)	DS 1
Measuring principle	eddy-current loss principle					
Target (blade material)	aluminium or titan					
Operating temperature	electronics	-30 to +70 °C				
	preamplifier	-30 to +125 °C				
	sensor	-40 to +200 °C				-40 to +235 °C
Maximum speed range	500 ... 400,000 RPM					
Distance sensor to blade	blade width < 1.2 mm	appr. 0.1 to 0.5 mm				0.1 to 1 mm
	blade width > 1.2 mm	appr. 0.1 to 0.7 mm				0.1 to 1.5 mm
	adjusting with LED-indicator (green)					
Number of blades	programmable divider (jumper) from 2 to 17 blades					
Output 1 (digital)	1 pulse/blade (TTL-level with 7 μs pulse width)					
Output 2 (digital)	1 pulse/rotation (TTL-level with 100 μs pulse width)					
Output 3 (analog)	jumper 1	0 ... 10 V (0 ... 200,000 RPM)				
	jumper 2	0 ... 10 V (0 ... 400,000 RPM)				
	linearity	load resistance min 1 kOhm, load capacitance max. 1 nF output frequency 1.5 to 100 Hz (speed sloping)				
	resolution	±0.2 % FSO 0.1 % FSO				
Power supply	9 V ... 30 VDC / max.150 mA (short time to 36 VDC)					
Sensor cable	with preamplifier DV135	any cable length up to max. 25 m; any BNC cable (impedance 75 Ohm or 95 Ohm)				
	without preamplifier	total length appr. 6 m for direct operation (sensor cable CE5.5(59) necessary)				
Integral sensor cable	0.5 m ±0.15 m				0.75 m ±0.15 m	
Weight	controller DZ 135: appr. 380 g					
	preamplifier DV135: appr. 50 g					

FSO = Full Scale Output

## Accessories

### PC 130-3, 3 m

Supply and signal cable

tinned ends for feeding (open ends)

analog output and 2 x TTL-signal on

BNC connector

### CE135-10, BNC-cable, 10 m

Cable extension between preamplifier and controller, operation temperature up to 200 °C

### CE5,5(59), cable extension

only for use without preamplifier DZ135

**turboSPEED DZ 135** Dimensions in mm, not to scale

**Sensor DS05(03)**

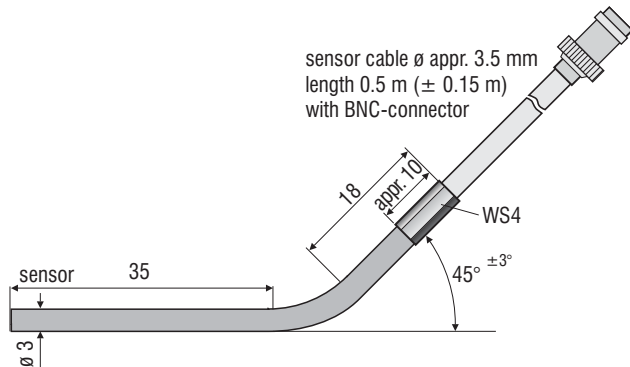

**Sensor DS05(14)**

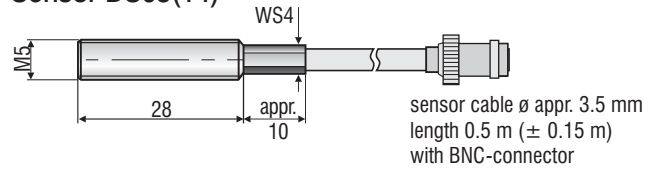

**Sensor DS05(15)**

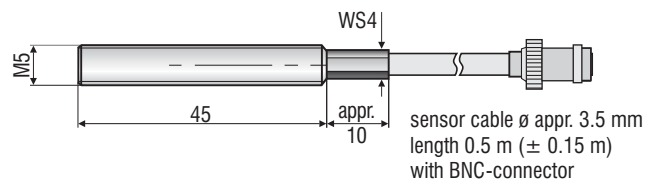

**Sensor DS05(04)**

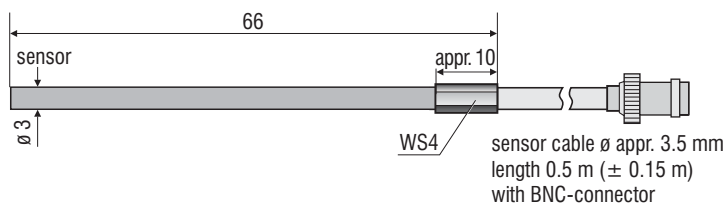

**Sensor DS1**

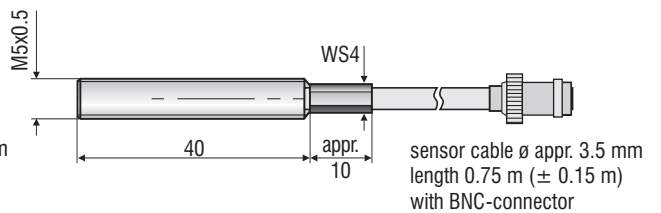

**Sensor DS05(07)**

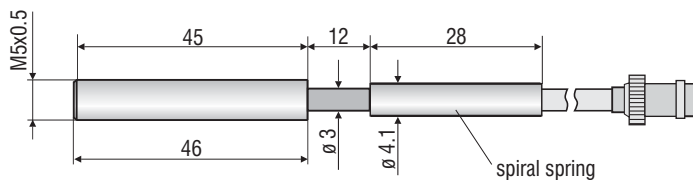

**Mounting adapter MA135**

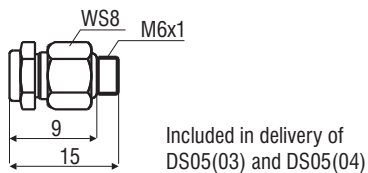

**Preamplifier DV135**

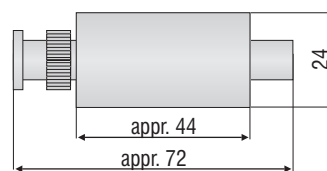

**Controller DZ 135**

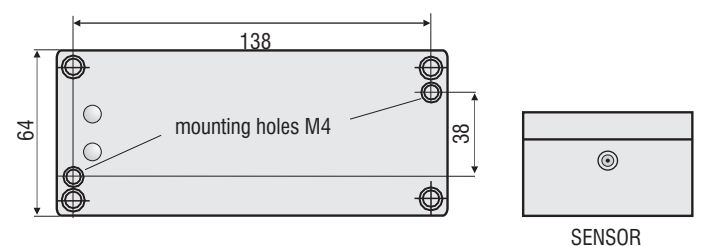
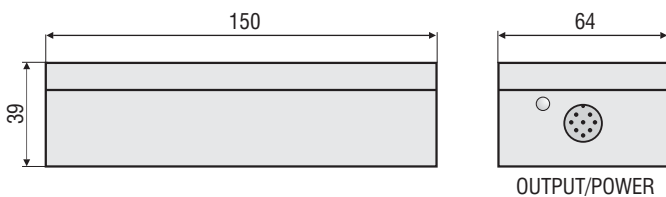

**MICRO-EPSILON**

info@micro-epsilon.com  
www.micro-epsilon.com

info@micro-epsilon.co.uk  
www.micro-epsilon.co.uk

info@micro-epsilon.us  
www.micro-epsilon.us

certified DIN EN ISO 9001 : 2000  
modifications reserved / Y9761093-B030108DGO

