



More Precision

optoNCDT // Laser displacement sensors (triangulation)



Laser triangulation sensors optoNCDT

optoNCDT - Highest precision in laser displacement measurements

optoNCDT laser sensors set milestones for industrial laser displacement measurement. They stand out due to their size, measuring rate, functionality and, in particular, to their high precision. The current optoNCDT range comprises numerous sensor models, each of which is among the best in its class impressing in automation, inline quality assurance and machine building.

EtherCAT[®]

EtherNet/IP[®]

PROFINET[®]

Compact, robust and with integrated controller for easy integration

Measuring rate up to 49 kHz for dynamic measurement tasks

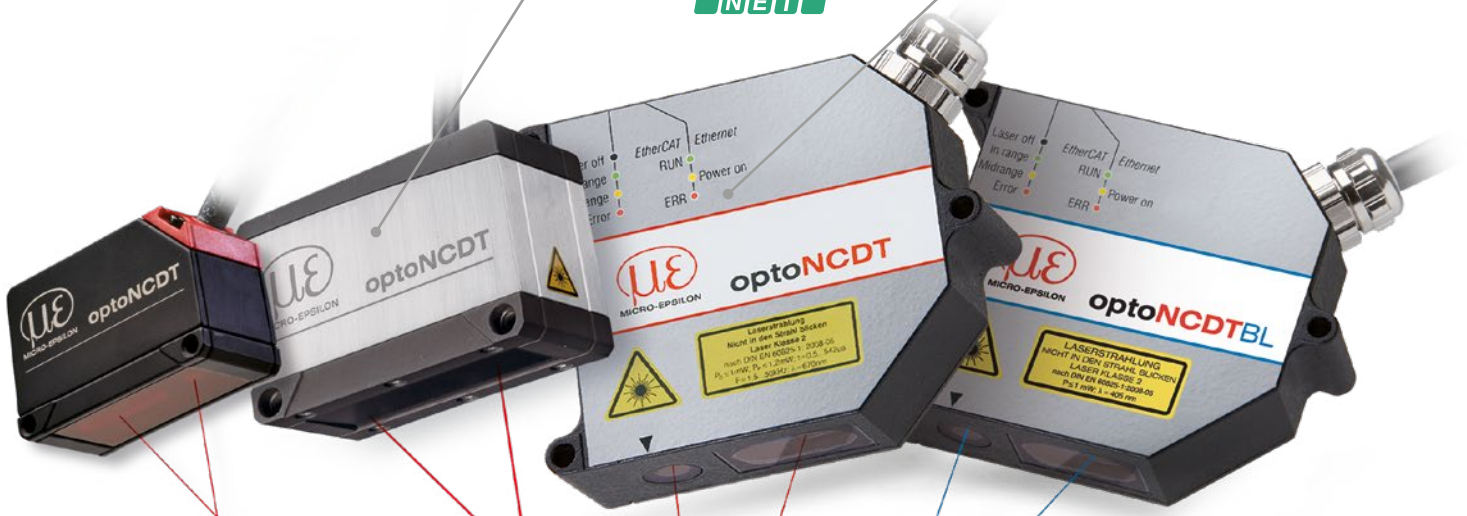

Small light spot (round) for finest details
Small laser line for metallic surfaces

Red laser and patented Blue laser for multiple measurement tasks

Measuring ranges from 2 to 1000 mm for smallest of details and large distances

Resolution from 30 nanometers for high precision measurements

Reliable on all measuring objects & surfaces



Shiny metallic

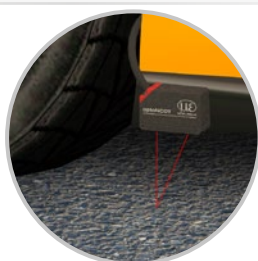

Dark/poorly reflecting



Different colors



(Semi-)transparent

General information		Page
Available models and model variants		4 - 5
Possible applications - the right technology for every application		6 - 7
Features		8 - 11
Application examples		12 - 13
Sensor type		Page
optoNCDT 1x20	Compact laser sensors for OEM and series use	14 - 23
optoNCDT 1900	Sensors for precision automation	24 - 33
optoNCDT 23x0	Precise laser sensors for dynamic measurement tasks	34 - 45
optoNCDT 17x0/1910	Laser sensors for special measurement tasks	46 - 59
Accessories		Page
Interface modules		60 - 61
Protective housings		62
sensorTOOL Software		63

optoNCDT 1x20

Miniature laser sensors for serial applications

from page 14

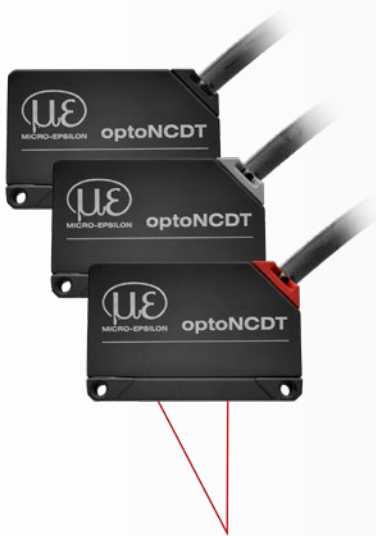

Model	Technology	Measuring range	Repeatability	Linearity
optoNCDT 1220		10 - 500 mm	1 μm	0.10 %
optoNCDT 1320		10 - 500 mm	1 μm	0.10 %
optoNCDT 1420		10 - 500 mm	0.5 μm	from 0.08 %
optoNCDT 1420LL		10 - 50 mm	0.5 μm	from 0.08 %
optoNCDT 1420CL1		10 - 50 mm	0.5 μm	from 0.08 %

optoNCDT 1900

High performance sensors for precision automation

from page 24



Model	Technology	Measuring range	Repeatability	Linearity
optoNCDT 1900		2 - 500 mm	0.1 μm	from 0.02 %
optoNCDT 1900LL		2 - 50 mm	0.1 μm	from 0.02 %

optoNCDT 23x0

High precision laser sensors

from page 34

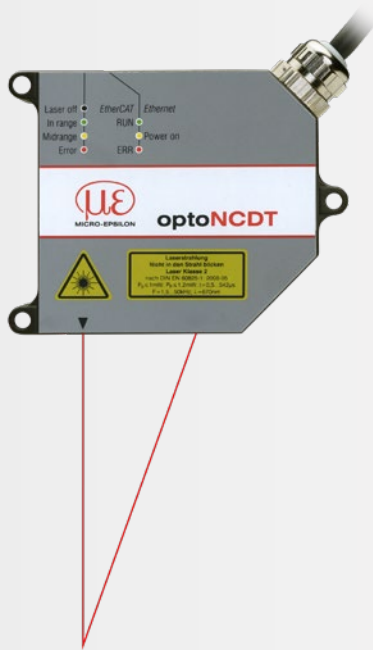

Model	Technology	Measuring range	Repeatability	Linearity
optoNCDT 2300		2 - 300 mm	0.03 μm	from 0.02 %
optoNCDT 2300BL		2 - 50 mm	0.03 μm	from 0.02 %
optoNCDT 2300LL		2 - 50 mm	0.1 μm	from 0.02 %
optoNCDT 2300-2DR		2 mm	0.03 μm	from 0.03 %
optoNCDT 2310		10 - 50 mm	0.5 μm	from 0.03 %

optoNCDT 17x0

Laser sensors for special measurement tasks

optoNCDT 1910

from page 46



Model	Technology	Measuring range	Repeatability	Linearity
optoNCDT 1750BL		2 - 750 mm	0.8 μm	from 0.06 %
optoNCDT 1750-DR		2 - 20 mm	0.1 μm	0.08 %
optoNCDT 1710		50 mm	from 7.5 μm	0.10 %
optoNCDT 1710BL		50 / 1000 mm	7.5 μm	from 0.10 %
optoNCDT 1760		1000 mm	from 7.5 μm	0.10 %
optoNCDT 1910		500 / 750 mm	from 20 μm	0.07 %

Measuring principle Laser triangulation

Laser triangulation sensors operate with a laser diode that projects a visible light spot onto the surface of the target. The light reflected from the spot is imaged by an optical receiving system onto a position-sensitive element. If the light spot changes its position, this change is imaged on the receiving element and evaluated.

The optoNCDT sensors use different technologies, which show their advantages in certain applications.

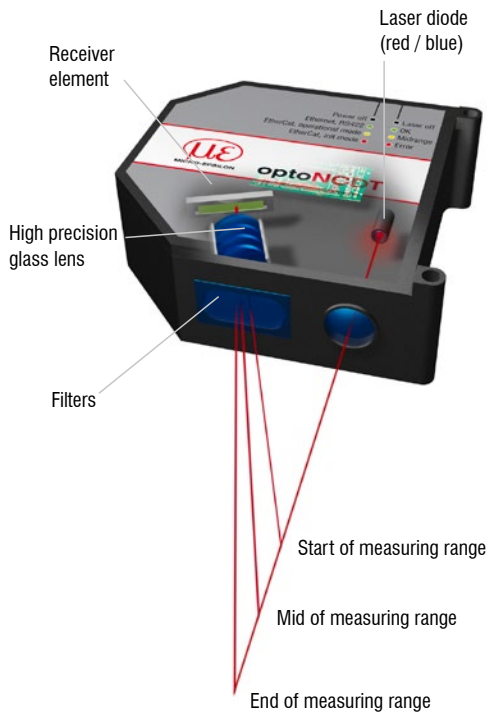

Laser point sensors with red laser

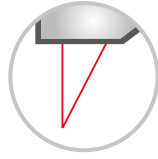

Triangulation sensors with a red laser are designed for diffusely reflecting measuring objects such as ceramics, plastics or matt metals.

The red laser has a high light intensity and is therefore also suitable for poorly reflecting objects, as the amount of light projected onto the sensor element is sufficient.

- Ultra-small light spot detects smallest details and structures
- Ideal for numerous surfaces
- Even for poorly reflecting surfaces
- Standard as laser class 2, optional as class 1 and class 3 laser



Laser line sensors with oval-shaped light spot

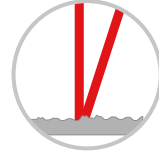

Rough and structured surfaces cause interferences within the laser point (left) which leads to a faulty projection on the sensor element. This effect becomes particularly obvious with metallic surfaces.

The small laser line of the optoNCDT LL sensors compensates for this effect (right) and enables stable measurements on metallic surfaces.

- Laser-line sensors for reliable measurements on rough and structured metallic surfaces
- No penetration, therefore also suitable for plastic and organic materials such as wood



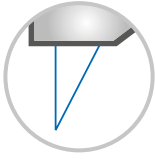

Blue laser sensors for challenging surfaces

The optoNCDT Blue Laser (BL) models use a blue-violet laser beam which does not penetrate the measuring object due to its shorter wavelength. The light spot is projected sharply to enable stable and precise measurement results.

The Blue Laser Technology is preferably used with red-hot glowing metals as well as organic and transparent objects.

- Ultra-small light spot detects smallest details and structures
- Ideal for numerous surfaces
- Patented for measurement tasks with red-hot measuring objects above 700 °C and transparent objects

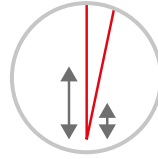

Long-range sensors for large distances

Some measurement tasks require a large measuring range or a large distance from the object to be measured.

Long-range sensors from Micro-Epsilon combine large measuring ranges and large offset distances. They enable high accuracy measurements from a safe distance.

- Measurement from a great distance up to 2000 mm
- Available with red laser and blue laser

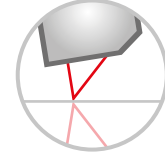
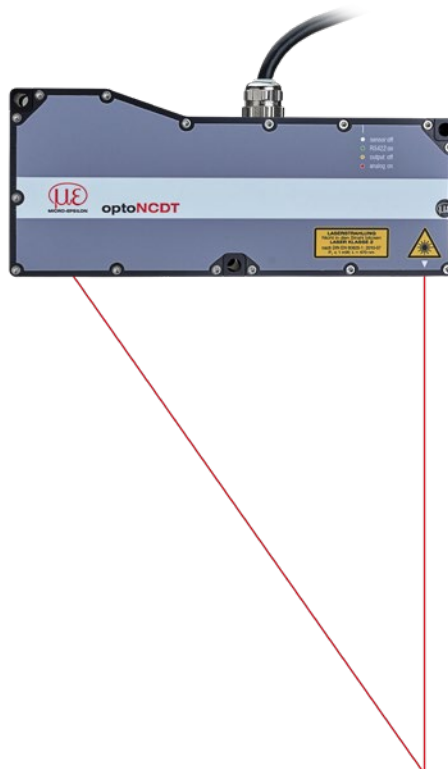

Direct-reflection sensors for shiny & mirroring targets

Conventional laser triangulation sensors are designed for diffuse reflecting surfaces. Specular surfaces such as shiny plastics, mirror glass or polished metals require a sensor alignment where the angle of incidence is equal to the angle of reflection.

Micro-Epsilon offers sensors with special alignment (DR) for directly reflecting surfaces which ensure high accuracy and signal stability.

- Ideal for distance measurements on shiny and mirroring surfaces
- Available with red laser and blue laser



More Precision optoNCDT Laser sensors

Always the right measuring range

optoNCDT laser triangulation sensors measure from a large distance to the target using a very small light spot. The large measurement distance enables non-contact measurements to be taken against difficult surfaces such as hot metals. More than 70 standard models with measuring ranges from 2 – 1000 mm cater for a large number of applications across many different industries.

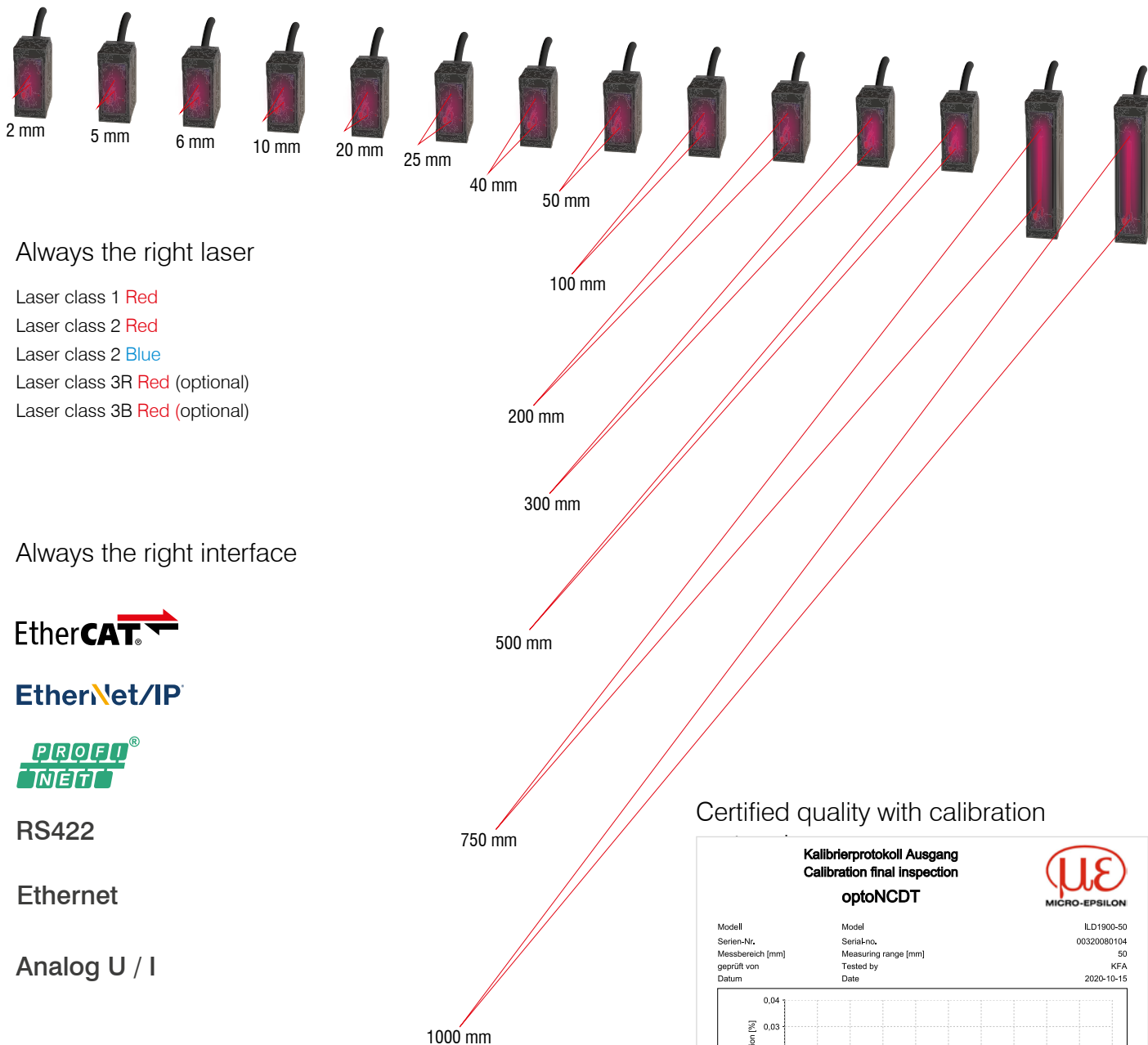

Always the right laser

- Laser class 1 Red
- Laser class 2 Red
- Laser class 2 Blue
- Laser class 3R Red (optional)
- Laser class 3B Red (optional)

Always the right interface

EtherCAT®

EtherNet/IP®

PROFINET®

RS422

Ethernet

Analog U / I

Certified quality with calibration

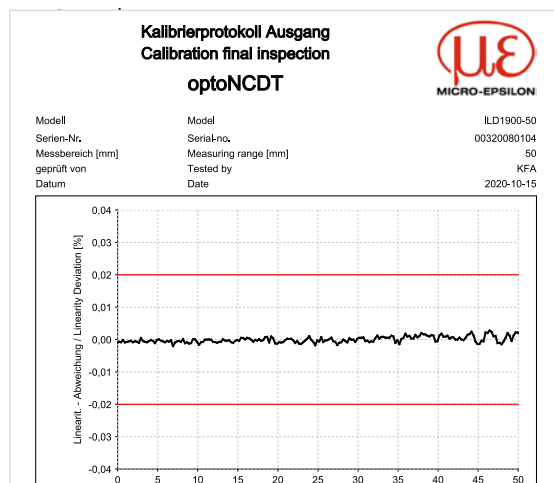

To document the performance capability, each sensor is tested and delivered with its own calibration protocol. This document is included in delivery or accessible via web interface.



Compact sensors with integrated controller

optoNCDT laser sensors are extremely compact and equipped with a fully integrated controller. This makes installation and wiring quick and easy. Therefore, these laser sensors can be easily installed even in restricted spaces



Highest ambient light compensation up to 50,000 lux

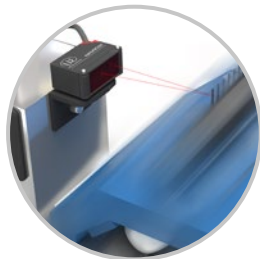

Excellent shock and vibration resistance



Robust and durable sensor design (IP67)



Extremely high temperature stability

Precise measurements in industrial environments

The optoNCDT sensors are designed for measurement tasks in factory automation, machines and systems. As a result, simple installation and wiring is possible in confined spaces or on a robot. Their high performance enables the sensors to provide precise measurement results at a high measuring rate.

Unique ease of use via web interface

The optoNCDT sensors are operated using an intuitive web interface. Therefore, the sensor is connected to a PC and the web interface is called up in a browser. This convenient web interface enables the user to make numerous settings for the processing of measured values and signals, e.g., peak selection, filter and masking features for the video signal.

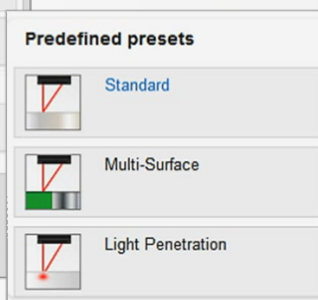
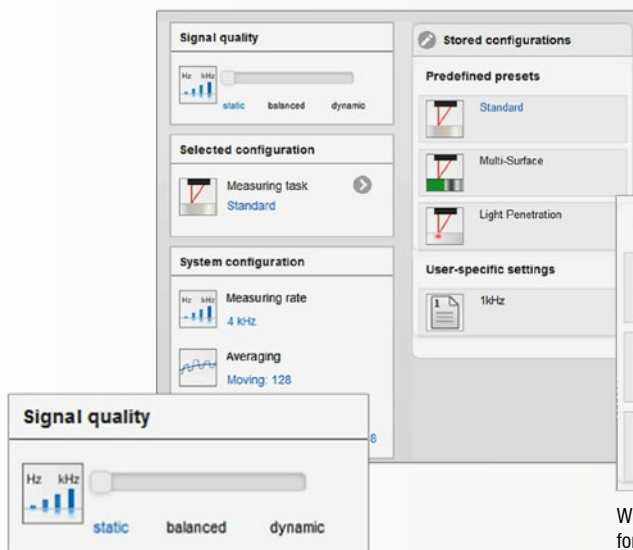
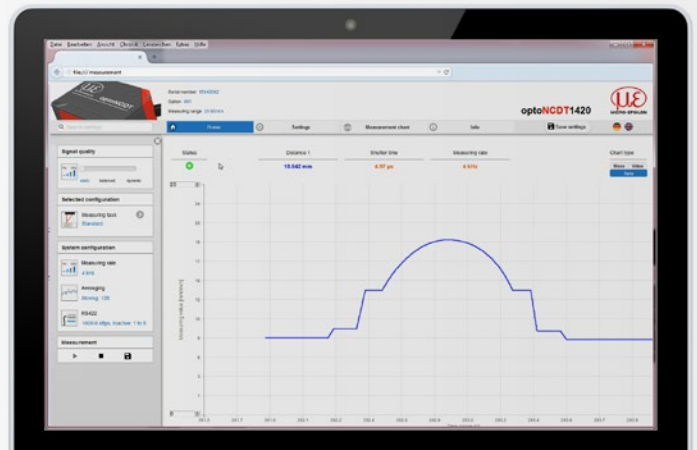

e.g., metal, ceramics,...

e.g., circuit boards, PCB,...

e.g., milk glass, plastics,....

With the presets, predefined sensor settings for specific measuring objects can be quickly and easily adopted.

The quality slider enables the user to define the signal evaluation regarding process and measurement dynamics. Depending on the selected settings, the measuring rate and the averaging of the sensor are adapted.

Advantages & outstanding features optoNCDT Laser sensors

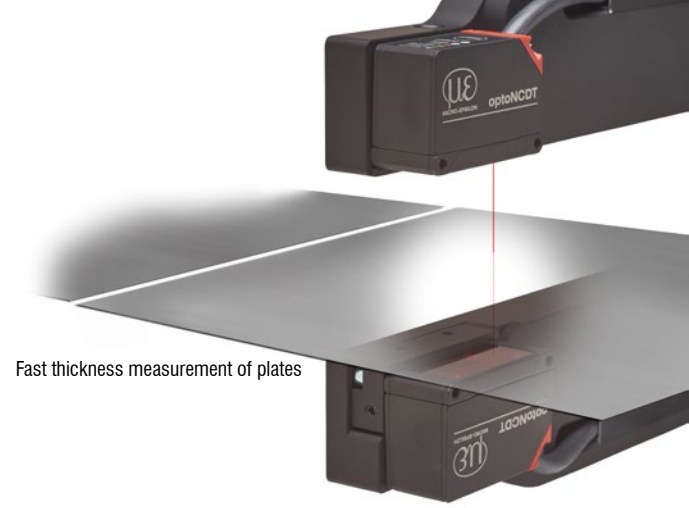

Fast thickness measurement of plates

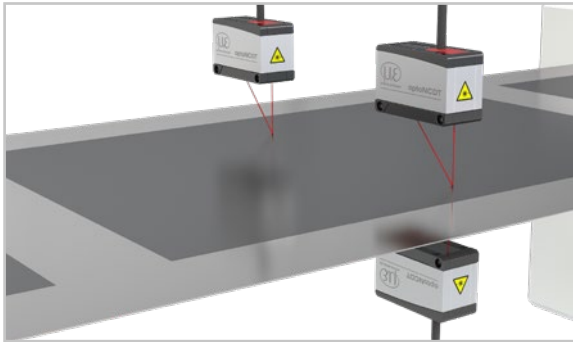

Synchronization for multi-track and thickness measurements

Operating several laser sensors to measure multiple track or the thickness requires synchronization. Synchronizing ensures that the measurement values of the sensors are recorded at the same time.

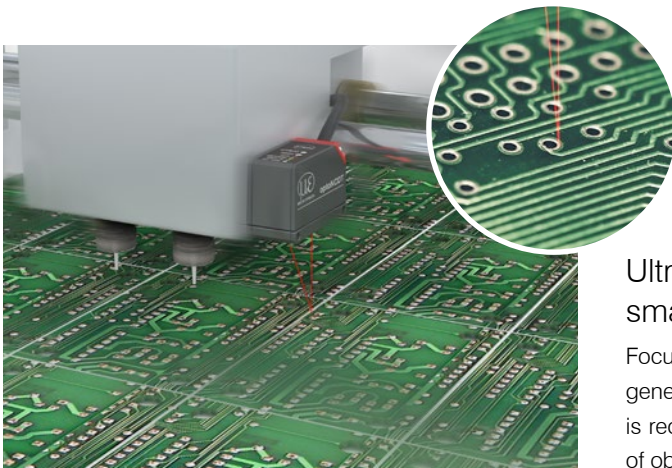

Measurement spot from $8.5 \times 11 \mu\text{m}$
for the detection of the smallest of details

Ultra-small light spot detects smallest details & structures

Focusing the laser beam via a special lens arrangement in the sensor generates a small light spot on the target surface. This small light spot is required for a high spatial resolution and ensures that the smallest of objects and details can be detected.



Ideal for robotic
applications

Ideal for drag chains and robots

The robust design allows the optoNCDT sensors to be used even with high accelerations, e.g. at the end effector. Compact and with integrated controller as well as robot-compatible cables, the optoNCDT sensors can be used for a wide range of measurement tasks on robots and in traversing systems.

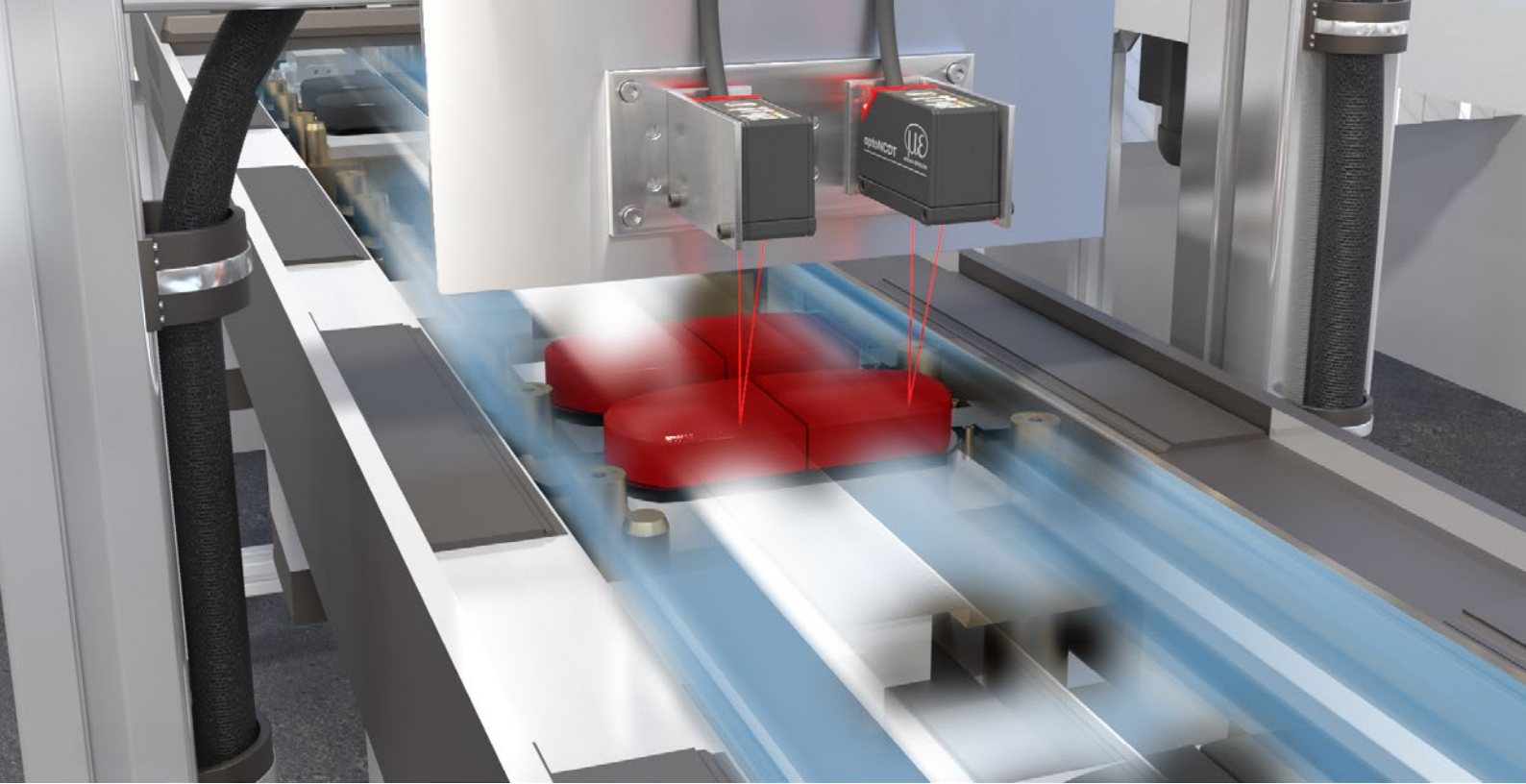

Ideal for fast control & positioning

When measuring poorly reflective surfaces or fast moving objects, high measuring rates are required. The optoNCDT sensors operate at high measuring rates with simultaneous surface compensation and are therefore able to reliably check dynamic processes.

High precision with changing surfaces

optoNCDT sensors are equipped with intelligent control features which ensure high signal stability with bright/dark transition, regardless of the color and the brightness of the measuring object. This optimally adjusts the exposure time or the amount of light for the exposure cycle just performed or the next exposure cycle. These controls enable smooth signal courses without outliers even in dynamic measurements.

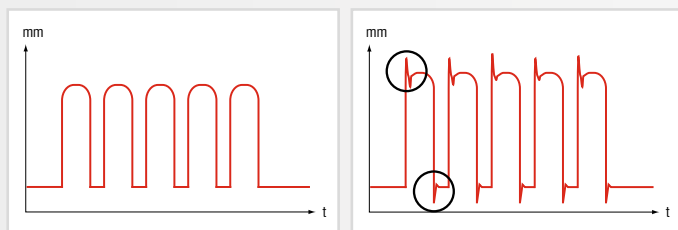

Comparison: optoNCDT sensor surface compensation (left) and conventional sensor providing faulty measurements with changing reflections (right)

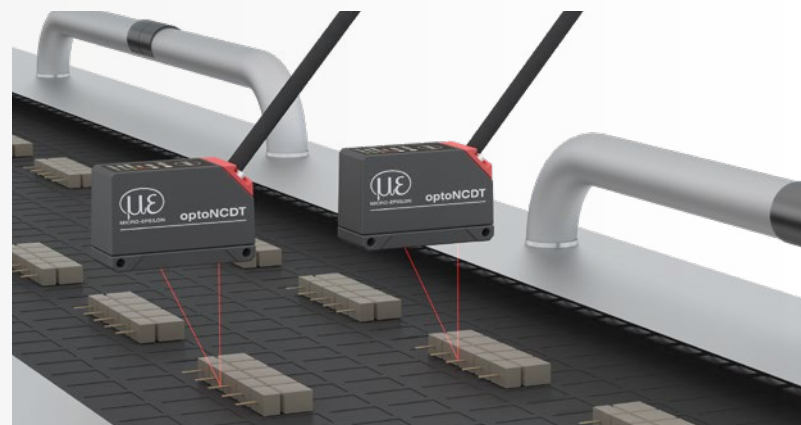

The Active Surface Compensation provides stable distance signal control regardless of target color or brightness.



The Advanced Surface Compensation feature operates with innovative algorithms and enables stable measurement results even on demanding surfaces.



The Real-time Surface Compensation feature compensates for changing reflectance properties in the current measurement cycle. Each individual laser pulse is controlled in real time depending on the surface properties of the measuring object.



The Advanced Real Time Surface Compensation with its improved dynamic range enables a more precise real time surface compensation. This ensures maximum compensation of fluctuating reflectivity while generating stable measurement values with high accuracy.

Application examples

optoNCDT Laser sensors

Print head positioning and focal point control

In printing processes, the exact height of the print head is a crucial factor for the quality of the final product. High-speed distance measurement against different material surfaces and reliable edge detection enable fast readjustments to be made to the process.

Sensor: *optoNCDT 1420*

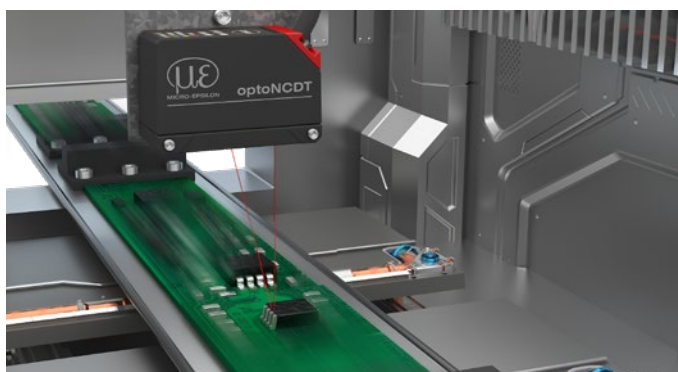
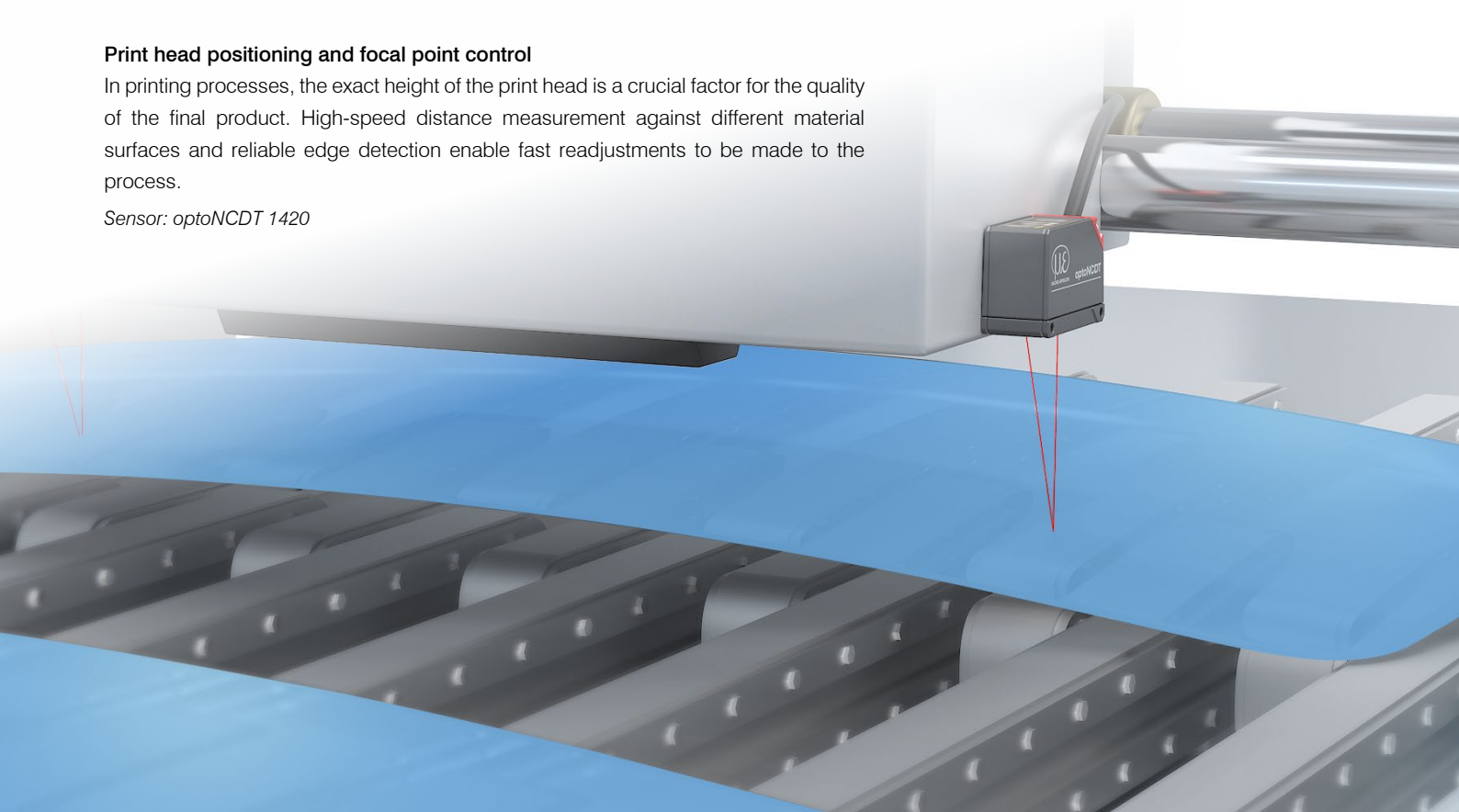

High resolution inspection in assembly processes

During PCB assembly, the presence and position of the components is checked using optoNCDT laser sensors. Regardless of surface reflections, these sensors provide precise measurement results and detect even the tiniest parts reliably.

Sensor: *optoNCDT 1420*

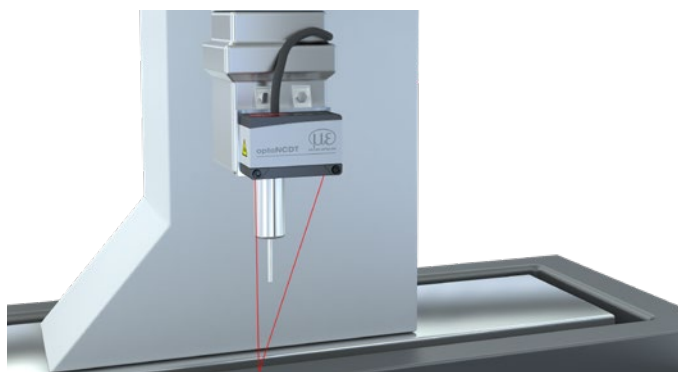

Positioning gauge heads in measuring machines

optoNCDT laser triangulation sensors are used to position sensor heads quickly. Thanks to their advanced sensor technology, the laser sensors enable exact distance control of the sensor head.

Sensor: *optoNCDT 1900*

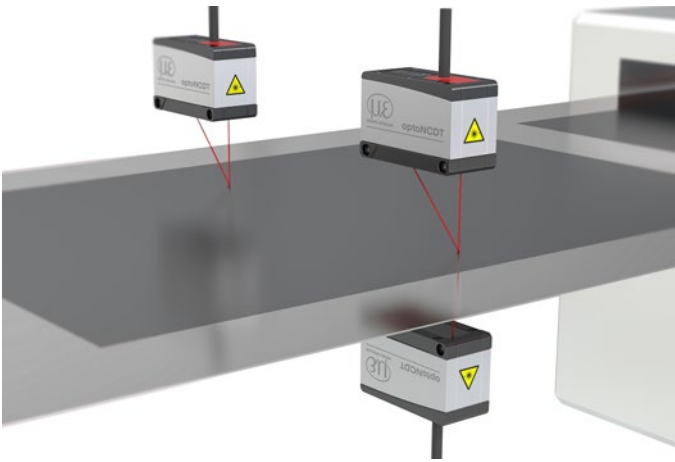

Thickness measurement of coated electrodes

The coating thickness is tested to ensure the homogeneous quality of battery films. The optoNCDT laser sensors enable a resolution in the sub-micrometer range. The thickness values are used to control the application of the coating and for quality assurance purposes.

Sensor: *optoNCDT 1900LL*

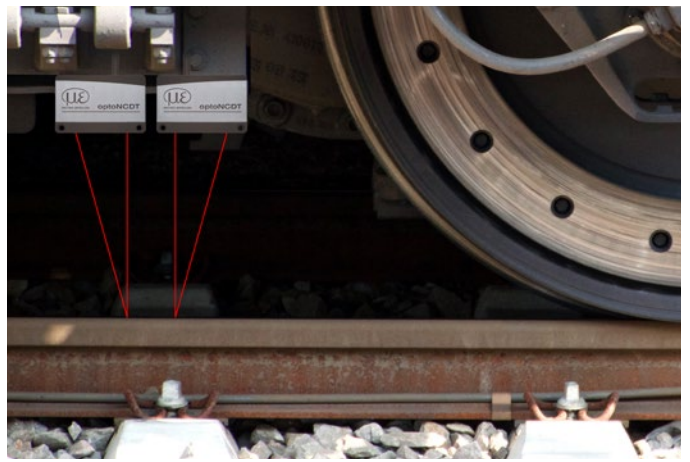

Measuring the wear of high-speed railway lines

For the maintenance of high-speed tracks, special measurement wagons are used. They are equipped with optoNCDT 1900LL laser displacement sensors, which detect the distance to the track at a high measuring rate. These robust sensors are hardly affected by fluctuating reflections and ambient light.

Sensor: *optoNCDT 1900LL*

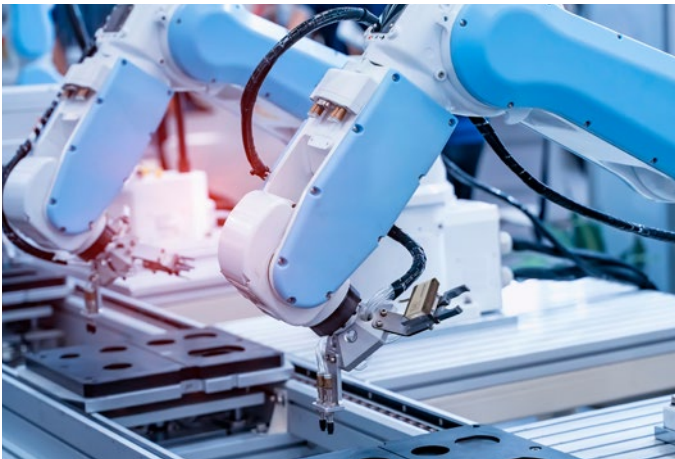

Position detection in robotic applications

Precise positioning is required for automated machining processes with robots. optoNCDT laser sensors are therefore used for distance measurement. Thanks to the compact design with integrated controller, the sensors are ideal for integration on robots and end effectors.

Sensor: *optoNCDT 1900*

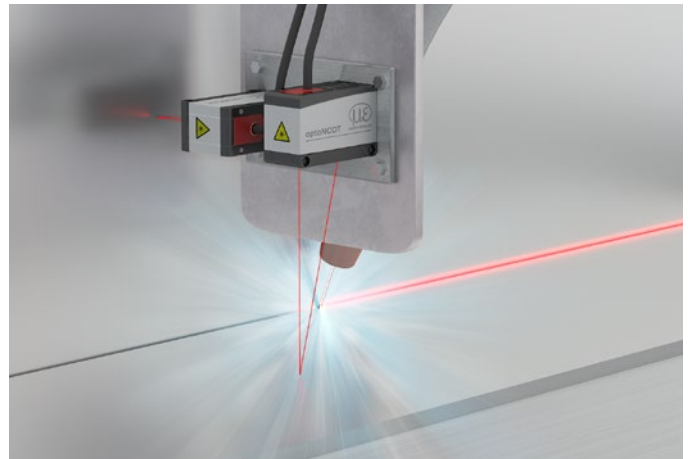







Distance control with fully automatic laser welding

In order to position the welding head at the correct distance, optoNCDT laser sensors are used. These measure the distance from the steel plates with high accuracy. Thanks to their enormous insensitivity to ambient light, the sensors are ideal for measurement tasks in welding automation.

Sensor: *optoNCDT 1900*

High precision laser sensors in miniature design optoNCDT 1220 / 1320 / 1420

designed for advanced
AUTOMATION

-  Measuring rate up to 8 kHz
-  **INTER FACE** Analog (U/I) / RS422 / PROFINET / EtherNet/IP / EtherCAT
-  **ASC** Active Surface Compensation
-  Repeatability 0.5 μm
-  Ideal for series and OEM applications
-  Low weight, ideal for high accelerations



Best in Class:

Compact, precise and faster

The optoNCDT 1x20 laser sensors are among the best in their class. The sensors offer a unique combination of speed, size and performance. The laser sensors are used for the precise measurement of displacement, distance and position in all fields of automation technology, such as machine building, 3D printers and robotics.

The optoNCDT 1x20 sensors use an intelligent surface control feature. The Active Surface Compensation (ASC) ensures stable measurement results regardless of changing colors or brightness of the target surface.

Ideal for industrial series applications

Different output signals enable the sensor to be integrated into plant and machine control systems. As well as analog voltage and current outputs, a digital RS422 interface provides distance information from the sensor.

Due to the universal setting and evaluation possibilities, the optoNCDT 1x20 sensors meet all the requirements for use in industrial series and OEM applications.

Model	Technology	Measuring range	Repeatability	Linearity
optoNCDT 1220		10 - 500 mm	1 μm	0.10 %
optoNCDT 1320		10 - 500 mm	1 μm	0.10 %
optoNCDT 1420		10 - 500 mm	0.5 μm	from 0.08 %
optoNCDT 1420LL		10 - 50 mm	0.5 μm	from 0.08 %
optoNCDT 1420CL1		10 - 50 mm	0.5 μm	from 0.08 %

Highest precision in a minimum of space

Compact size combined with low weight opens up new fields of application. The selectable connector type, i.e. cable or pigtail, together with compact size reduce the sensor installation effort to a minimum.

Now even more powerful!

The optoNCDT 1x20 sensors have been optimized for industrial series use. Furthermore, the robust IP67 sensor housing allows use in industrial environments, even with high accelerations. A high-performance D/A converter enables 16 bit resolution at the analog output. Therefore, the sensor achieves even more precise measurement results. With the doubled measuring rate, even faster measurements can now be performed.



Application examples



Dimension control of turned parts

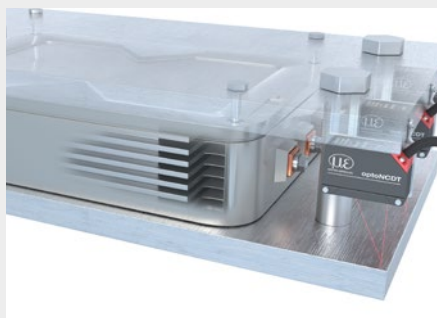

Monitoring the expansion of battery cells

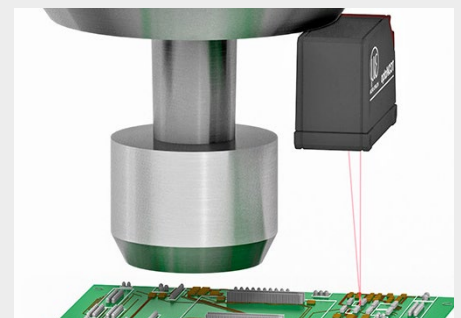

Distance control of print heads

Technical data

optoNCDT 1220 / 1320



Laser point - optoNCDT 1220

Model	ILD1220-10	ILD1220-25	ILD1220-50	ILD1220-100	ILD1220-200	ILD1220-500	
Measuring range	10 mm	25 mm	50 mm	100 mm	200 mm	500 mm	
Start of measuring range	20 mm	25 mm	35 mm	50 mm	60 mm	100 mm	
Mid of measuring range	25 mm	37.5 mm	60 mm	100 mm	160 mm	350 mm	
End of measuring range	30 mm	50 mm	85 mm	150 mm	260 mm	600 mm	
Measuring rate ^[1]	4 adjustable stages: 2 kHz / 1 kHz / 0.5 kHz / 0.25 kHz						
Linearity ^[2]	< ±10 μm	< ±25 μm	< ±50 μm	< ±100 μm	< ±200 μm	< ±750 μm ... 1500 μm	
	< ±0.10 % FSO					< ±0.15 % ... 0.30 % FSO	
Repeatability ^[3]	1 μm	2.5 μm	5 μm	10 μm	20 μm	50 μm	
Temperature stability ^[4]	±0.015 % FSO / K			±0.01 % FSO / K			
Light spot diameter ^[5]	SMR	90 x 120 μm	100 x 140 μm	90 x 120 μm	750 x 1100 μm	750 x 1100 μm	750 x 1100 μm
	MMR	45 x 40 μm	120 x 130 μm	230 x 240 μm			
	EMR	140 x 160 μm	390 x 500 μm	630 x 820 μm			
	smallest Ø	45 x 40 μm with 24 mm	55 x 50 μm with 31 mm	70 x 65 μm with 42 mm	-	-	
Light source	Semiconductor laser < 1 mW, 670 nm (red)						
Laser class	Class 2 in accordance with IEC 60825-1: 2014						
Permissible ambient light ^[6]	20,000 lx				7,500 lx		
Supply voltage	11 ... 30 VDC						
Power consumption	< 2 W (24 V)						
Signal input	1 x HTL laser on/off; 1 x HTL multifunction input: trigger in, zero setting, teach						
Digital interface	RS422 (16 bit)						
Analog output	4 ... 20 mA (16 bit, freely scalable within the measuring range)						
Switching output	1 x error output: npn, pnp, push pull						
Connection	integrated cable 2 m, open ends, minimum bending radius 30 mm (fixed installation)						
Installation	Screw connection via two mounting holes						
Temperature range	Storage	-20 ... +70 °C (non-condensing)					
	Operation	0 ... +50 °C (non-condensing)					
Shock (DIN EN 60068-2-27)	15 g / 6 ms in 3 axes, 1000 shocks each						
Vibration (DIN EN 60068-2-6)	20 g / 20 ... 500 Hz in 3 axes, 2 directions and 10 cycles each						
Protection class (DIN EN 60529)	IP67						
Material	Aluminum housing						
Weight	approx. 30 g (without cable), approx. 110 g (incl. cable)						
Control and indicator elements ^[7]	Select button: zero, teach, factory settings; web interface for setup; 2 x color LEDs for power / status						

^[1] Factory setting 1 kHz, modifying the factory setting requires the IF2001/USB converter (see accessories)

^[2] FSO = Full Scale Output; the specified data apply to white, diffuse reflecting surfaces (Micro-Epsilon reference ceramic for ILD sensors)

^[3] Measuring rate 1 kHz, median 9

^[4] The specified value is only achieved by mounting on a metallic sensor holder. Good heat dissipation from the sensor to the holder must be ensured.

^[5] ±10 %; SMR = Start of measuring range; MMR = Mid of measuring range; EMR = End of measuring range

^[6] Illuminant: light bulb

^[7] Access to web interface requires connection to PC via IF2001/USB (see accessories)



Laser point - optoNCDT 1320

Model	ILD1320-10	ILD1320-25	ILD1320-50	ILD1320-100	ILD1320-200	ILD1320-500	
Measuring range	10 mm	25 mm	50 mm	100 mm	200 mm	500 mm	
Start of measuring range	20 mm	25 mm	35 mm	50 mm	60 mm	100 mm	
Mid of measuring range	25 mm	37.5 mm	60 mm	100 mm	160 mm	350 mm	
End of measuring range	30 mm	50 mm	85 mm	150 mm	260 mm	600 mm	
Measuring rate ^[1]	5 adjustable stages: 4 kHz / 2 kHz / 1 kHz / 0.5 kHz / 0.25 kHz						
Linearity ^[2]	< ±10 μm	< ±25 μm	< ±50 μm	< ±100 μm	< ±200 μm	< ±600 μm ... ±1200 μm	
	< ±0.10 % FSO					< ±0.12 ... ±0.24 % FSO	
Repeatability ^[3]	1 μm	2.5 μm	5 μm	10 μm	20 μm	50 μm	
Temperature stability ^[4]	±0.015 % FSO / K			±0.01 % FSO / K			
Light spot diameter ^[5]	SMR	90 x 120 μm	100 x 140 μm	90 x 120 μm	750 x 1100 μm	750 x 1100 μm	750 x 1100 μm
	MMR	45 x 40 μm	120 x 130 μm	230 x 240 μm			
	EMR	140 x 160 μm	390 x 500 μm	630 x 820 μm	-	-	-
	smallest Ø	45 x 40 μm with 24 mm	55 x 50 μm with 31 mm	70 x 65 μm with 42 mm	-	-	-
Light source	Semiconductor laser < 1 mW, 670 nm (red)						
Laser class	Class 2 in accordance with IEC 60825-1: 2014						
Permissible ambient light ^[6]	30,000 lx			20,000 lx	7,500 lx		
Supply voltage	11 ... 30 VDC						
Power consumption	< 2 W (24 V)						
Signal input	1 x HTL laser on/off; 1 x HTL multifunction input: trigger in, zero setting, teach						
Digital interface ^[7]	RS422 (16 bit) / EtherCAT / PROFINET / EtherNet/IP						
Analog output	4 ... 20 mA (16 bit, freely scalable within the measuring range)						
Switching output	1 x error output: npn, pnp, push pull						
Connection	integrated cable 3 m, open ends, minimum bending radius 30 mm (fixed installation)						
Installation	Screw connection via two mounting holes						
Temperature range	Storage	-20 ... +70 °C (non-condensing)					
	Operation	0 ... +50 °C (non-condensing)					
Shock (DIN EN 60068-2-27)	15 g / 6 ms in 3 axes, 1000 shocks each						
Vibration (DIN EN 60068-2-6)	20 g / 20 ... 500 Hz in 3 axes, 2 directions and 10 cycles each						
Protection class (DIN EN 60529)	IP67						
Material	Aluminum housing						
Weight	approx. 30 g (without cable), approx. 145 g (incl. cable)						
Control and indicator elements ^[8]	Select button: zero, teach, factory settings; web interface for setup with defined presets; 2 x color LEDs for power / status						

^[1] Factory setting 2 kHz, modifying the factory setting requires the IF2001/USB converter (see accessories)

^[2] FSO = Full Scale Output; the specified data apply to white, diffuse reflecting surfaces (Micro-Epsilon reference ceramic for ILD sensors)

^[3] Measuring rate 1 kHz, median 9

^[4] The specified value is only achieved by mounting on a metallic sensor holder. Good heat dissipation from the sensor to the holder must be ensured.

^[5] ±10 %; SMR = Start of measuring range; MMR = Mid of measuring range; EMR = End of measuring range

^[6] Illuminant: light bulb

^[7] For EtherCAT, PROFINET and EtherNet/IP, connection via interface module is required (see accessories)

^[8] Access to web interface requires connection to PC via IF2001/USB (see accessories)

Technical data

optoNCDT 1420

optoNCDT 1420 (General technical data)

Model	ILD1420-xx	
Measuring rate ^[1]	6 adjustable stages: 8 kHz / 4 kHz / 2 kHz / 1 kHz / 0.5 kHz / 0.25 kHz	
Supply voltage	11 ... 30 VDC	
Power consumption	< 2 W (24 V)	
Signal input	1 x HTL laser on/off; 1 x HTL multifunction input: trigger in, zero setting, teach	
Digital interface ^[2]	RS422 (16 bit) / EtherCAT / PROFINET / EtherNet/IP	
Analog output ^[3]	4 ... 20 mA / 1 ... 5 V with PCF1420-3/U cable (16 bit, freely scalable within the measuring range)	
Switching output	1 x error output: npn, pnp, push pull	
Connection	integrated cable 3 m, open ends, min. bending radius 30 mm (fixed installation) or integrated pigtail 0.3 m with 12-pin M12 plug (see accessories for suitable connection cable)	
Installation	Screw connection via two mounting holes	
Temperature range	Storage	-20 ... +70 °C (non-condensing)
	Operation	0 ... +50 °C (non-condensing)
Shock (DIN EN 60068-2-27)	15 g / 6 ms in 3 axes, 1000 shocks each	
Vibration (DIN EN 60068-2-6)	20 g / 20 ... 500 Hz in 3 axes, 2 directions and 10 cycles each	
Protection class (DIN EN 60529) ^[4]	IP67	
Material	Aluminum housing	
Weight	approx. 60 g (incl. pigtail), approx. 145 g (incl. cable)	
Control and indicator elements ^[5]	Select button: zero, teach, factory setting; web interface for setup: selectable presets, peak selection, video signal, freely selectable averaging, data reduction, setup management; 2 x color LEDs for power / status	

^[1] Factory setting 4 kHz, modifying the factory setting requires the IF2001/USB converter (see accessories)
For models with laser class 1 the maximum measuring rate is 4 kHz

^[2] For EtherCAT, PROFINET and EtherNet/IP connection via interface module is required (see accessories)

^[3] For models with laser class 1 the D/A conversion is done with 12 bit

^[4] Models with laser class 1 have the protection class IP65

^[5] Access to web interface requires connection to PC via IF2001/USB (see accessories)



Laser point - optoNCDT 1420

Model		ILD1420-10	ILD1420-25	ILD1420-50	ILD1420-100	ILD1420-200	ILD1420-500
Measuring range		10 mm	25 mm	50 mm	100 mm	200 mm	500 mm
Start of measuring range		20 mm	25 mm	35 mm	50 mm	60 mm	100 mm
Mid of measuring range		25 mm	37.5 mm	60 mm	100 mm	160 mm	350 mm
End of measuring range		30 mm	50 mm	85 mm	150 mm	260 mm	600 mm
Linearity ^[1]		< ±8 μm	< ±20 μm	< ±40 μm	< ±80 μm	< ±160 μm	< ±500 ... ±1000 μm
		< ±0.08 % FSO					< ±0.1 ... ±0.2 % FSO
Repeatability ^[2]		0.5 μm	1 μm	2 μm	4 μm	8 μm	20 ... 40 μm
Temperature stability ^[3]		±0.015 % FSO / K			±0.01 % FSO / K		
Light spot diameter ^[4]	SMR	90 x 120 μm	100 x 140 μm	90 x 120 μm	750 x 1100 μm	750 x 1100 μm	750 x 1100 μm
	MMR	45 x 40 μm	120 x 130 μm	230 x 240 μm			
	EMR	140 x 160 μm	390 x 500 μm	630 x 820 μm			
	smallest Ø	45 x 40 μm with 24 mm	55 x 50 μm with 31 mm	70 x 65 μm with 42 mm	-	-	-
Light source		Semiconductor laser < 1 mW, 670 nm (red)					
Laser class		Class 2 in accordance with IEC 60825-1: 2014					
Permissible ambient light ^[5]		50,000 lx			30,000 lx	10,000 lx	

^[1] FSO = Full Scale Output; the specified data apply to white, diffuse reflecting surfaces (Micro-Epsilon reference ceramic for ILD sensors)

^[2] Measuring rate 2 kHz, median 9

^[3] The specified value is only achieved by mounting on a metallic sensor holder. Good heat dissipation from the sensor to the holder must be ensured.

^[4] ±10 %; SMR = Start of measuring range; MMR = Mid of measuring range; EMR = End of measuring range

^[5] Illuminant: light bulb



Laser line - optoNCDT 1420LL

Model	ILD1420-10LL	ILD1420-25LL	ILD1420-50LL	
Measuring range	10 mm	25 mm	50 mm	
Start of measuring range	20 mm	25 mm	35 mm	
Mid of measuring range	25 mm	37.5 mm	60 mm	
End of measuring range	30 mm	50 mm	85 mm	
Linearity ^[1]	< ±8 μm	< ±20 μm	< ±40 μm	
	< ±0.08 % FSO			
Repeatability ^[2]	0.5 μm	1 μm	2 μm	
Temperature stability ^[3]	±0.015 % FSO / K			
Light spot diameter ^[4]	SMR	140 x 720 μm	220 x 960 μm	240 μm x 1250 μm
	MMR	65 x 680 μm	80 x 970 μm	130 μm x 1450 μm
	EMR	140 x 660 μm	240 x 1000 μm	380 μm x 1650 μm
	smallest Ø	65 x 680 μm with 25 mm	80 x 970 μm with 37.5 mm	110 x 1400 μm with 52.5 mm
Light source	Semiconductor laser < 1 mW, 670 nm (red)			
Laser class	Class 2 in accordance with IEC 60825-1: 2014			
Permissible ambient light ^[5]	50,000 lx			

^[1] FSO = Full Scale Output; the specified data apply to white, diffuse reflecting surfaces (Micro-Epsilon reference ceramic for ILD sensors)

^[2] Measuring rate 2 kHz, median 9

^[3] The specified value is only achieved by mounting on a metallic sensor holder. Good heat dissipation from the sensor to the holder must be ensured.

^[4] ±10 %; SMR = Start of measuring range, MMR = Mid of measuring range, EMR = End of measuring range

Light spot diameter with line-shaped laser determined based on the emulated 90/10 knife-edge method

^[5] Illuminant: light bulb



Laser class 1 - optoNCDT 1420 CL1

Model	ILD1420-10CL1	ILD1420-25CL1	ILD1420-50CL1	
Measuring range	10 mm	25 mm	50 mm	
Start of measuring range	20 mm	25 mm	35 mm	
Mid of measuring range	25 mm	37.5 mm	60 mm	
End of measuring range	30 mm	50 mm	85 mm	
Linearity ^[1]	< ±8 μm	< ±20 μm	< ±40 μm	
	< ±0.08 % FSO			
Repeatability ^[2]	0.5 μm	1 μm	2 μm	
Temperature stability ^[3]	±0.015 % FSO / K			
Light spot diameter ^[4]	SMR	90 x 120 μm	100 x 140 μm	90 x 120 μm
	MMR	45 x 40 μm	120 x 130 μm	230 x 240 μm
	EMR	140 x 160 μm	390 x 500 μm	630 x 820 μm
	smallest Ø	45 x 40 μm with 24mm	55 x 50 μm with 31 mm	70 x 65 μm with 42 mm
Light source	Semiconductor laser < 0.39 mW, 670 nm (red)			
Laser class	Class 1 in accordance with DIN EN 60825-1: 2015-07			
Permissible ambient light ^[5]	15,000 lx			

^[1] FSO = Full Scale Output; the specified data apply to white, diffuse reflecting surfaces (Micro-Epsilon reference ceramic for ILD sensors)

^[2] Measuring rate 2 kHz, median 9

^[3] The specified value is only achieved by mounting on a metallic sensor holder. Good heat dissipation from the sensor to the holder must be ensured.

^[4] ±10 %; SMR = Start of measuring range, MMR = Mid of measuring range, EMR = End of measuring range

^[5] Illuminant: light bulb

Dimensions

optoNCDT 1220 / 1320 / 1420

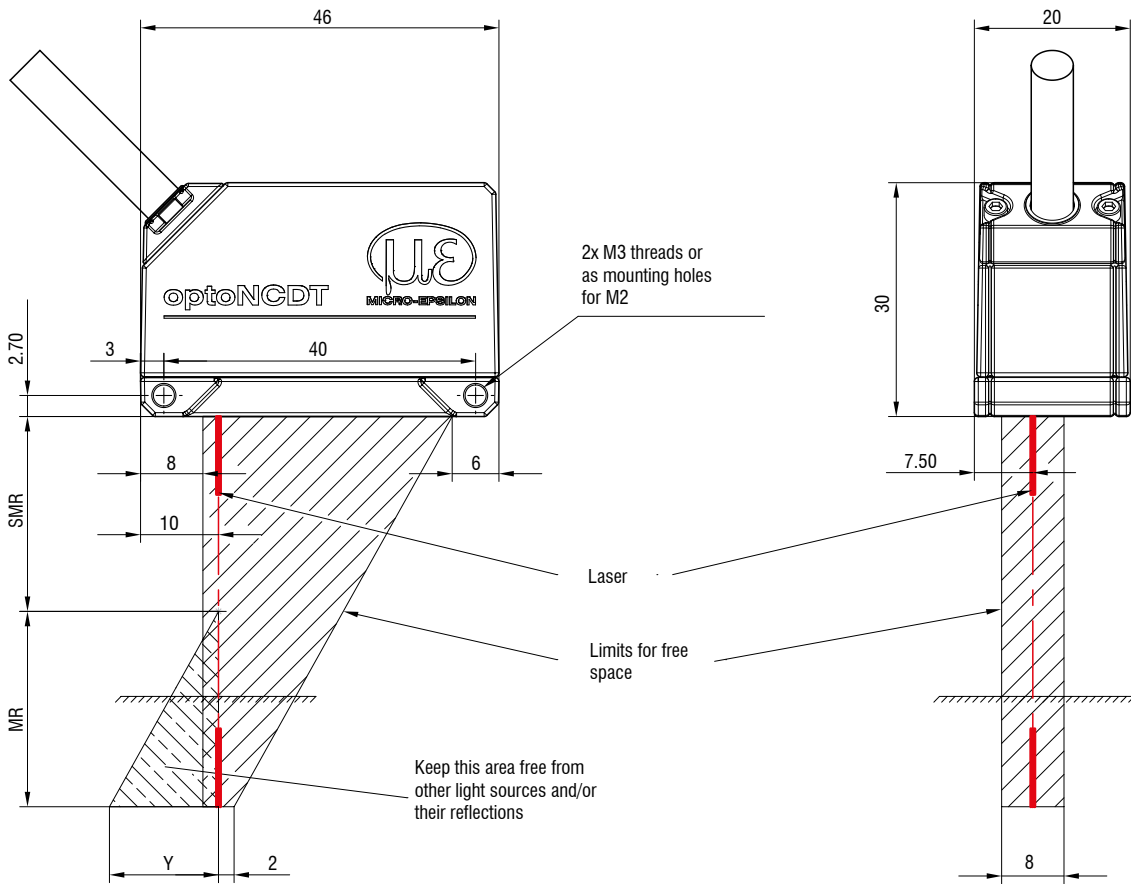

MR	SMR	Y
10	20	10
25	25	21
50	35	28
100	50	46
200	60	70
500	100	190

(Dimensions in mm, not to scale)

MR = measuring range; SMR = start of measuring range;

MMR = mid of measuring range; EMR = end of measuring range

Connector (sensor side)

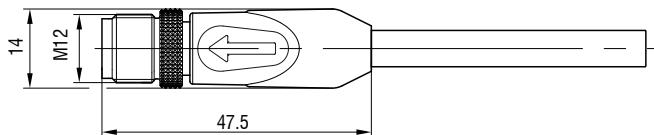

Installation options

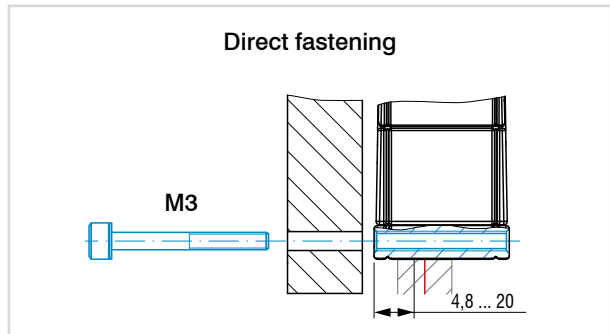
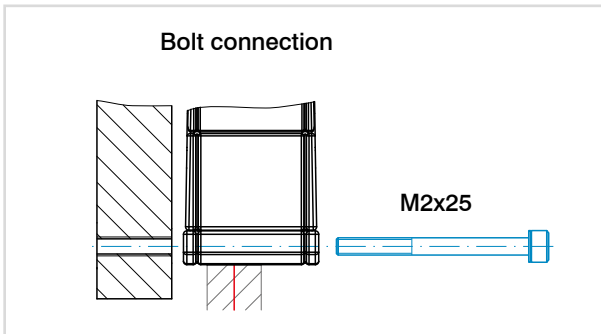

Accessories for optoNCDT 1220/1320/1420

Power supply unit

PS2020 (power supply 24 V / 2.5 A, input 100 - 240 VAC, output 24 VDC / 2.5 A, mounting onto symmetrical standard rail 35 mm x 7.5 mm, DIN 50022)

Protective film

Transparent protective film 32 x 11 mm for ILD1x20

Scope of supply

- 1 ILD1x20 sensor
- 1 Assembly instructions
- 1 digital calibration protocol accessible via web interface
- Accessories (2x M2 screws and 2 washers)

Article designation

ILD1420-	10	LL	CL1
			Laser class No indication: class 2 (standard) CL1: Class 1 (only with ILD1420)
			Laser type No indication: Red laser point (standard) LL: Laser Line (only with ILD1420)
Measuring range in mm			
Series			
ILD1220: Compact laser displacement sensor for OEM and serial applications			
ILD1320: Compact laser triangulation displacement sensor			
ILD1420: Smart laser triangulation displacement sensor			

Connection possibilities

optoNCDT 1220 / 1320 / 1420

Sensors with integrated cable

Cable diameter:	5.40 ±0.2 mm
Drag chain:	no
Robot:	no
Temperature range:	-25 ... 105 °C (moving) -40 ... 105 °C (not moving)
Bending radius:	> 27 mm (fixed installation) > 54 mm (dynamic)

Sensor	Cables	Type	Connection possibilities and accessories
ILD1220-xx	Integrated cable Length 2 m	Open ends	Supply voltage connection Power supply unit PS2020
ILD1320-xx ILD1420-xx ILD1420-xxLL	Integrated cable Length 3 m		Interface module of RS422 to USB IF2001/USB IC2001/USB
			Interface module for Industrial Ethernet connection IF2035-PROFINET IF2035-EIP IF2035-EtherCAT



Drag-chain suitable extension and adapter cables

Cable diameter:	6.0 ±0.2 mm
Drag chain:	yes
Robot:	no (optional on request)
Temperature range:	-40 ... 90 °C
Bending radius:	> 30 mm (fixed installation) > 60 mm (dynamic)

Sensor	Cables	Type	Connection possibilities and accessories
ILD1420-xx ILD1420-xxLL	Extension cable pigtail Length 3 m / 6 m / 10 m / 15 m <i>Art. no.</i> <i>Designation</i> 29011067 PCF1420-3/I 29011068 PCF1420-6/I 29011069 PCF1420-10/I 29011070 PCF1420-15/I 29011071 PCF1420-3/U 29011072 PCF1420-6/U 29011073 PCF1420-10/U 29011074 PCF1420-15/U	Open ends	Supply voltage connection Power supply unit PS2020
	Adapter cable for PC interface card Length 3 m / 6 m / 10 m <i>Art. no.</i> <i>Designation</i> 29011079 PCF1420-3/IF2008 29011088 PCF1420-6/IF2008 29011089 PCF1420-10/IF2008	Sub-D	Interface module of RS422 to USB IF2001/USB IC2001/USB
	Adapter cable for sensor calculation Length 3 m / 6 m / 9 m <i>Art. no.</i> <i>Designation</i> 29011171 PCF1420-3/C-Box 29011172 PCF1420-6/C-Box 29011170 PCF1420-9/C-Box	Sub-D	Interface module for Industrial Ethernet connection IF2035-PROFINET IF2035-EIP IF2035-EtherCAT
	Adapter cable for sensor calculation Length 2 m <i>Art. no.</i> <i>Designation</i> 29011149 PCE1420-2/M12	M12	Interface card for synchronous data acquisition IF2008PCIe / IF2008E
			4-fold interface module from RS422 to USB IF2004/USB
			Controller for D/A conversion and evaluation of up to 2 sensor signals Dual Processing Unit
			Interface module for Ethernet connection of up to 8 sensors IF2008/ETH









Other cables

Cable diameter:	6.7 mm
Drag chain:	yes
Robot:	no
Temperature range:	-40 ... 80 °C
Bending radius:	> 27 mm (fixed installation) > 51 mm (dynamic)

Input	Cables	Type	Connection possibilities and accessories					
2 x Sub-D (PCF1420-x/ IF2008)	<p>Adapter cable for the connection of two sensors per Sub-D connector Length 0.1 m</p> <table> <tr> <td><i>Art. no.</i></td> <td><i>Designation</i></td> </tr> <tr> <td>2901528</td> <td>IF2008-Y-adapter cable</td> </tr> </table> 	<i>Art. no.</i>	<i>Designation</i>	2901528	IF2008-Y-adapter cable	Sub-D	<p>Interface card for synchronous data acquisition IF2008PCle / IF2008E</p> 	<p>4-fold interface module from RS422 to USB IF2004/USB</p> 
<i>Art. no.</i>	<i>Designation</i>							
2901528	IF2008-Y-adapter cable							

Smart laser sensors for precise measurements optoNCDT 1900

designed for advanced
AUTOMATION

-  For common surfaces
-  Measuring rate up to 10 kHz
-  **INTERFACE** Analog (U/I) / RS422 / PROFINET / EtherNet/IP / EtherCAT
-  **ASc** Advanced Surface Compensation
-  Repeatability $<0.1 \mu\text{m}$
-  Ideal for series and OEM applications
-  Highest immunity to ambient light
-  High resistance to shocks and vibrations



Next-generation laser sensors

The optoNCDT 1900 laser sensors are used for dynamic displacement, distance and position measurements and offer a unique combination of performance, design and integration capability. The integrated high-performance controller enables fast and highly precise processing and output of measurement values.

These innovative sensors are used whenever maximum precision is combined with the latest technology, e.g., in sophisticated automation, automotive production, 3D printing and coordinate measuring machines.

Advanced Surface Compensation – The intelligent exposure control for demanding surfaces

The optoNCDT 1900 laser sensors are equipped with an intelligent surface control feature. Innovative algorithms enable stable measurement results even on demanding surfaces where changing reflections occur. Furthermore, these new algorithms compensate for ambient light up to 50,000 lux. Therefore, these are the sensors with the highest resistance to ambient light in their class and can even be used in strongly illuminated environments.

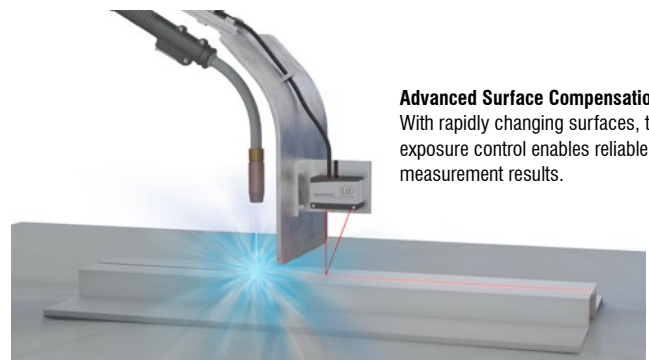

Advanced Surface Compensation
With rapidly changing surfaces, the exposure control enables reliable measurement results.

Industrial Ethernet for easy integration



The latest optoNCDT 1900 laser triangulation sensors are also available with integrated Industrial Ethernet interface. Depending on the model, you can integrate the full sensor performance into your PLC directly via EtherCAT, EtherNet/IP or PROFINET without any additional interface module. You benefit from real-time data without time delay as well as reduced installation and wiring effort.

The sensor parameters can be set directly via Industrial Ethernet or still via web interface. For high speed measurements, the sensor offers an Oversampling feature which allows, depending on the fieldbus, measurement data to be detected or transmitted eight times faster than the bus cycles.

EtherCAT®

EtherNet/IP®

PROFINET®

Model	Technology	Measuring range	Repeatability	Linearity
optoNCDT 1900		2 - 500 mm	0.1 μm	from 0.02 %
optoNCDT 1900LL		2 - 50 mm	0.1 μm	from 0.02 %

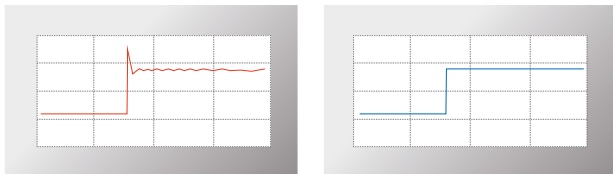
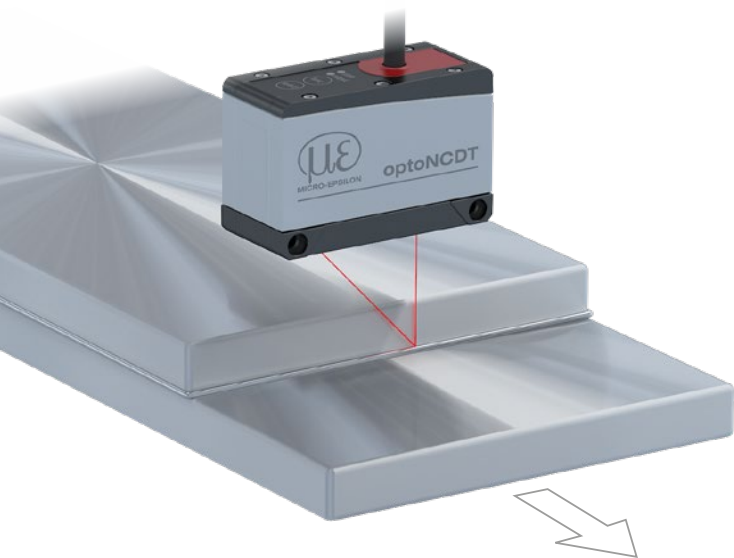

The two-step measurement value averaging enables smooth signal courses when measuring edges (right). Otherwise, interfering signals occur (left).

Highest stability based on intelligent signal optimization

For the first time, a two-step measurement value averaging feature is available to optimize the signal. This enables a smooth signal at edges and steps. Especially for high speed measurements of moving parts, measurement averaging enables a precise signal course.

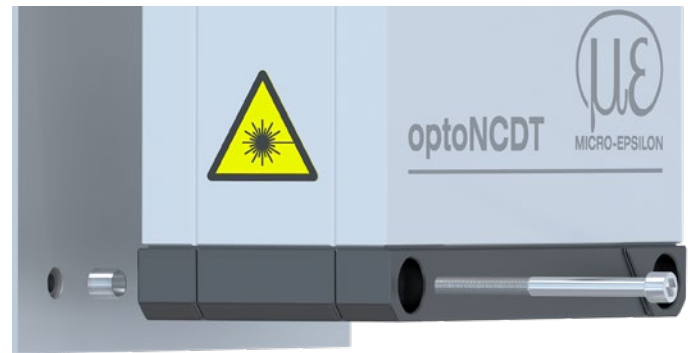

Patented installation

Easy mounting and high repeatability when replacing the sensor

Simple mounting and initial operation

Mounting the sensor using fitting sleeves automatically aligns the sensor in the correct position. This enables both easy sensor replacement and even higher precision in solving measurement tasks. Thanks to its small dimensions, the laser sensor can also be integrated in confined spaces.

Application examples

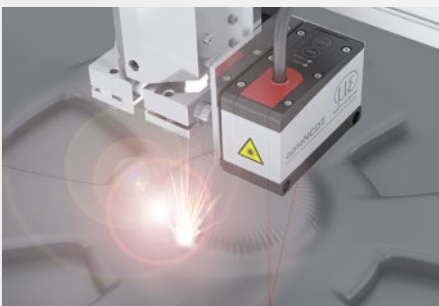

Distance measurement of print heads

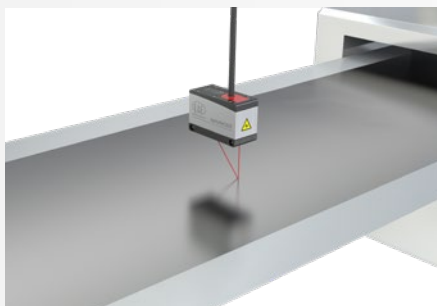

Thickness measurement of electrode film

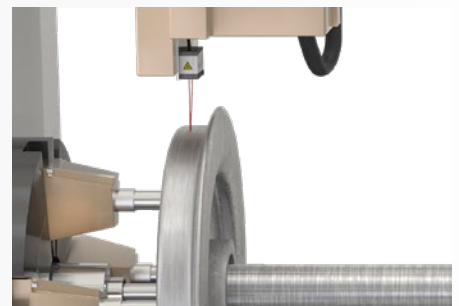

Wear inspection of wheel tires

Technical data

optoNCDT 1900

optoNCDT 1900 (General technical data)

Model		ILD1900-xx
Measuring rate ^[1]	7 adjustable stages: 10 kHz / 8 kHz / 4 kHz / 2 kHz / 1 kHz / 500 Hz / 250 Hz	
Temperature stability ^[2]	±0.005 % FSO / K	
Light source	Semiconductor laser ≤ 1 mW, 670 nm (red) with laser class 2	
Laser class	Class 2 in accordance with IEC 60825-1: 2014 (Class 3 available on request)	
Supply voltage	11 ... 30 VDC	
Power consumption	< 3 W (24 V)	
Signal input	1 x HTL/TTL laser on/off; 1 x HTL/TTL multi-function input: trigger in, slave in, zero setting, mastering, teach-in; 1 x RS422 synchronization input: trigger in, sync in, master/slave, master/slave alternating	
Digital interface ^[3]	RS422 (18 bit) / EtherCAT / PROFINET / EtherNet/IP	
Analog output	4 ... 20 mA / 0 ... 5 V / 0 ... 10 V (16 bit, freely scalable within the measuring range)	
Switching output	2x switching outputs (error & limit value): npn, pnp, push pull	
Connection	integrated cable 3 m, open ends, min. bending radius 30 mm (fixed installation); or integrated pigtail 0.3 m with 17-pin M12 plug; optional extension to 3 m / 6 m / 9 m / 15 m possible (suitable connection cable see Accessories)	
Temperature range	Storage	-20 ... +70 °C (non-condensing)
	Operation	0 ... +50 °C (non-condensing)
Shock (DIN EN 60068-2-27)	15 g / 6 ms in 3 axes	
Vibration (DIN EN 60068-2-6)	30 g / 20 ... 500 Hz	
Protection class (DIN EN 60529)	IP67	
Material	Aluminum housing	
Weight	approx. 185 g (incl. pigtail), approx. 300 g (incl. cable)	
Control and indicator elements ^[4]	Select & function keys: interface selections, mastering (zero), teach, presets, quality slider, frequency selection, factory settings; web interface for setup: application-specific presets, peak selection, video signal, freely selectable averaging possibilities, data reduction, setup management; 2 x color LEDs for power / status	

^[1] Factory setting: measuring rate 4 kHz, median 9; modifying the factory setting requires the IF2001/USB converter (see accessories)

^[2] Related to digital output in the mid of the measuring range; the specified value is only achieved by mounting on a metallic sensor holder. Good heat dissipation from the sensor to the holder must be ensured; value is valid in a range from 20 °C to 50 °C

^[3] EtherCAT, PROFINET and EtherNet/IP require connection via interface module (see accessories)

^[4] Access to web interface requires connection to PC via IF2001/USB (see accessories)

optoNCDT 1900 with integrated Industrial Ethernet interface (General technical data)



Model		ILD1900-xx with integrated Industrial Ethernet interface
Measuring rate ^[1]		7 adjustable stages: 10 kHz / 8 kHz / 4 kHz / 2 kHz / 1 kHz / 500 Hz / 250 Hz
Temperature stability ^[2]		±0.005 % FSO / K
Light source		Semiconductor laser ≤ 1 mW, 670 nm (red) with laser class 2
Laser class		Class 2 in accordance with IEC 60825-1: 2014 (Class 3 available on request)
Supply voltage ^[3]		11 ... 30 VDC or PoE
Power consumption		< 3 W (24 V)
Signal input		1 x HTL/TTL Laser on/off
Digital interface		EtherCAT / EtherNet/IP / PROFINET
Connection		integrated pigtail 0.3 m with 12-pin M12 plug; optional extension to 3 m / 6 m / 9 m (see accessories for suitable connection cables)
Temperature range	Storage	-20 ... +70 °C (non-condensing)
	Operation	0 ... +50 °C (non-condensing)
Shock (DIN EN 60068-2-27)		15 g / 6 ms in 3 axes
Vibration (DIN EN 60068-2-6)		30 g / 20 ... 500 Hz
Protection class (DIN EN 60529)		IP67
Material		Aluminum housing
Weight		approx. 185 g (incl. pigtail)
Control and indicator elements ^[4]		Select key: factory settings, switching the operation mode; web interface for setup: application-specific presets, peak selection, video signal, freely selectable averaging possibilities, data reduction, setup management; 1 x color LED for power / status; 2 x color LEDs for fieldbus status

^[1] Maximum measuring rate depending on fieldbus and bus cycle time; factory settings: measuring rate 4 kHz, median 9

^[2] In the mid of the measuring range; the specified value is only achieved by mounting on a metallic sensor holder. Good heat dissipation from the sensor to the holder must be ensured; value is valid in a range from 20 °C to 50 °C

^[3] PoE not possible with PROFINET

^[4] Connection to PC via network cable (with EtherCAT: sensor in Ethernet setup mode)

Technical data

optoNCDT 1900



Laser point - optoNCDT 1900 / Measuring ranges 2 - 25

Model		ILD1900-2	ILD1900-6	ILD1900-10	ILD1900-25
Measuring range		2 mm	6 mm	10 mm	25 mm
Start of measuring range		15 mm	17 mm	20 mm	25 mm
Mid of measuring range		16 mm	20 mm	25 mm	37.5 mm
End of measuring range		17 mm	23 mm	30 mm	50 mm
Linearity ^[1]		< ±1 µm	< ±1.8 µm	< ±2 µm	< ±5 µm
		< ±0.05 % FSO	< ±0.03 % FSO	< ±0.02 % FSO	< ±0.02 % FSO
Repeatability ^[2]		< 0.1 µm	< 0.25 µm	< 0.4 µm	< 0.8 µm
Light spot diameter ^[3]	SMR	60 x 75 µm	85 x 105 µm	115 x 150 µm	200 x 265 µm
	MMR	55 x 65 µm	57 x 60 µm	60 x 65 µm	70 x 75 µm
	EMR	65 x 75 µm	105 x 120 µm	120 x 140 µm	220 x 260 µm
	smallest Ø	55 x 65 µm with 16 mm	57 x 60 µm with 20 mm	60 x 65 µm with 25 mm	65 x 70 µm with 35 mm
Permissible ambient light		50,000 lx			

^[1] FSO = Full Scale Output; the specified data apply to white, diffuse reflecting surfaces (Micro-Epsilon reference ceramic for ILD sensors)

^[2] Typical value with measurements at 4 kHz and median 9

^[3] ±10 %; SMR = Start of measuring range; MMR = Mid of measuring range; EMR = End of measuring range

Light spot diameter determined using a point-shaped laser with Gaussian fit (full 1/e² width); for ILD1900-2: determined with emulated 90/10 knife-edge method



Laser point - optoNCDT 1900 / Measuring ranges 50 - 500

Model		ILD1900-50	ILD1900-100	ILD1900-200	ILD1900-500
Measuring range		50 mm	100 mm	200 mm	500 mm
Start of measuring range		40 mm	50 mm	60 mm	100 mm
Mid of measuring range		65 mm	100 mm	160 mm	350 mm
End of measuring range		90 mm	150 mm	260 mm	600 mm
Linearity ^[1]		< ±10 µm	< ±30 µm	< ±100 µm	< ±400 µm
		< ±0.02 % FSO	< ±0.03 % FSO	< ±0.05 % FSO	< ±0.08 % FSO
Repeatability ^[2]		< 1.6 µm	< 4 µm	< 8 µm	< 20 ... 40 µm
Light spot diameter ^[3]	SMR	220 x 300 µm	310 x 460 µm	950 x 1200 µm	950 x 1200 µm
	MMR	95 x 110 µm	140 x 170 µm		
	EMR	260 x 300 µm	380 x 410 µm		
	smallest Ø	85 x 90 µm with 55 mm	120 x 125 µm with 75 mm	-	-
Permissible ambient light		50,000 lx	30,000 lx	10,000 lx	10,000 lx

^[1] FSO = Full Scale Output; the specified data apply to white, diffuse reflecting surfaces (Micro-Epsilon reference ceramic for ILD sensors)

^[2] Typical value with measurements at 4 kHz and median 9

^[3] ±10 %; SMR = Start of measuring range; MMR = Mid of measuring range; EMR = End of measuring range

Light spot diameter determined using a point-shaped laser with Gaussian fit (full 1/e² width); for ILD1900-2: determined with emulated 90/10 knife-edge method



Laser-Line - optoNCDT 1900LL

Model		ILD1900-2LL	ILD1900-6LL	ILD1900-10LL	ILD1900-25LL	ILD1900-50LL
Measuring range		2 mm	6 mm	10 mm	25 mm	50 mm
Start of measuring range		15 mm	17 mm	20 mm	25 mm	40 mm
Mid of measuring range		16 mm	20 mm	25 mm	37.5 mm	65 mm
End of measuring range		17 mm	23 mm	30 mm	50 mm	90 mm
Linearity ^[1]		< ±1 μm	< ±1.2 μm	< ±2 μm	< ±5 μm	< ±10 μm
		< ±0.05 % FSO	< ±0.02 % FSO	< ±0.02 % FSO	< ±0.02 % FSO	< ±0.02 % FSO
Repeatability ^[2]		< 0.1 μm	< 0.25 μm	< 0.4 μm	< 0.8 μm	< 1.6 μm
Light spot diameter ^[3]	SMR	55 x 480 μm	100 x 600 μm	125 x 730 μm	210 x 950 μm	235 μm x 1280 μm
	MMR	40 x 460 μm	50 x 565 μm	55 x 690 μm	80 x 970 μm	125 μm x 1500 μm
	EMR	55 x 440 μm	100 x 525 μm	125 x 660 μm	220 x 1000 μm	325 μm x 1740 μm
	smallest Ø	40 x 460 μm with 16 mm	50 x 565 μm with 20 mm	55 x 690 μm with 25 mm	80 x 970 μm with 37.5 mm	115 x 1450 μm with 59 mm
Permissible ambient light		50,000 lx				

^[1] Related to digital output; FSO = Full Scale Output

The specified data apply to white, diffuse reflecting surfaces (Micro-Epsilon reference ceramic for ILD sensors)

^[2] Typical value with measurements at 4 kHz and median 9

^[3] ±10 %; SMR = Start of measuring range; MMR = Mid of measuring range; EMR = End of measuring range
Light spot diameter with line-shaped laser determined based on the emulated 90/10 knife-edge method

Dimensions optoNCDT 1900

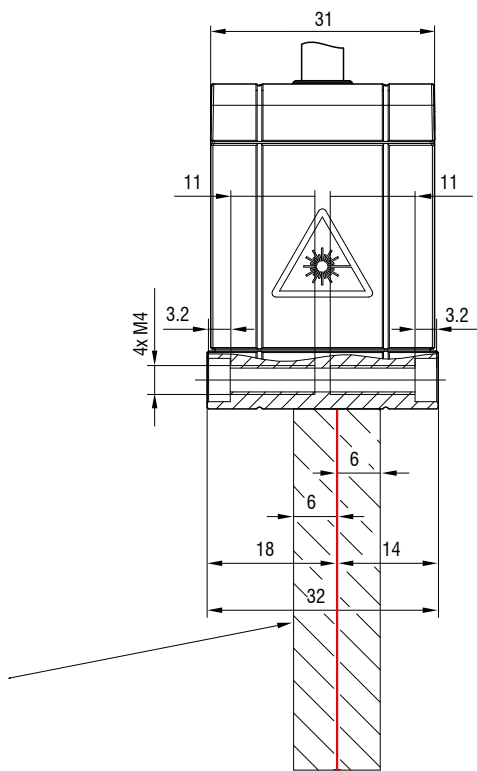
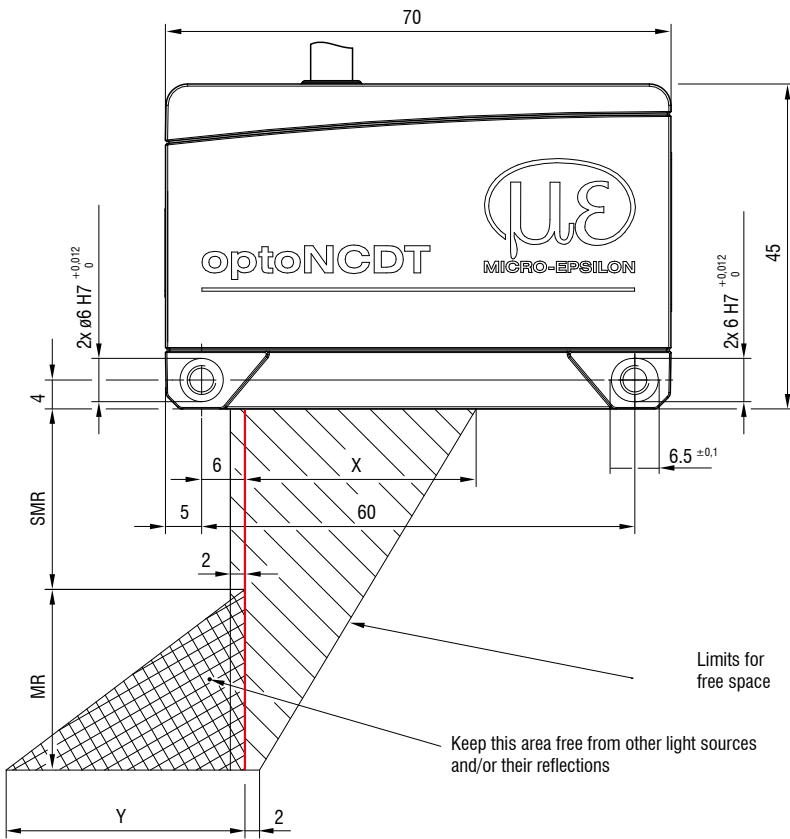

MR	SMR	X	Y
2	15	23	3
6	17	27	9
10	20	33	14
25	25	33	33
50	40	36	45
100	50	37	75
200	60	39	130
500	100	43	215

(Dimensions in mm, not to scale)
 MR = measuring range; SMR = start of measuring range
 MMR = mid of measuring range; EMR = end of measuring range

Connector (sensor side)

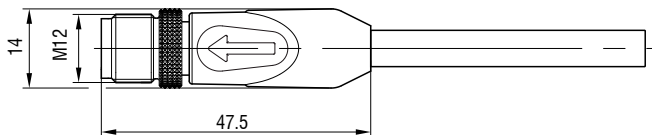

Installation options

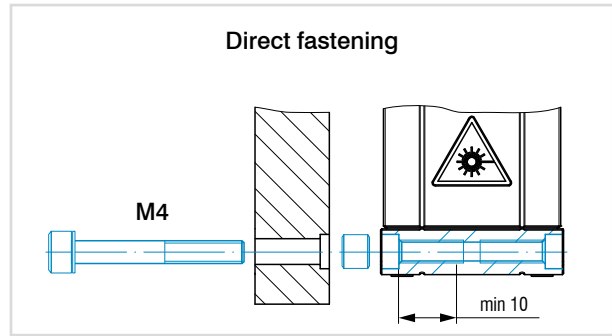
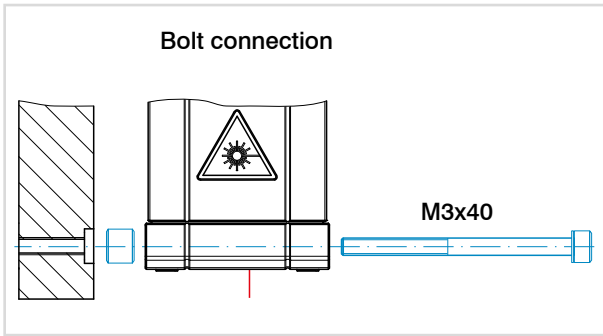

Accessories for optoNCDT 1900/1910

Power supply unit

PS2020 (power supply 24 V / 2.5 A, input 100 - 240 VAC, output 24 VDC / 2.5 A, mounting onto symmetrical standard rail 35 mm x 7.5 mm, DIN 50022)

Protective film

Transparent protective film 52 x 15 mm for IL1900

Protective housings

with air purge and cooling, see page 62

Scope of supply

- 1 Sensor IL1900/1910
- 1 Assembly instructions
- 1 Calibration protocol
- Accessories (2 pc. centering sleeves, 2 pc. M3 x 40)

Article designation



ILD1900-	6	LL	CL3B	EtherCAT
				Interface No indication: RS422, current, voltage (standard) integrated fieldbus: EtherCAT, EtherNet/IP, PROFINET
				Laser class No indication: class 2 (standard) 3B: on request 3R: on request
				Laser type No indication: Red laser point (standard) LL: Laser Line
Measuring range in mm				
Series ILD1900: Laser displacement sensor for Advanced Automation				

Connection possibilities

optoNCDT 1900







Connection possibilities for sensors with integrated cables

Cable diameter: 5.80 ±0.2 mm
 Drag chain: yes
 Robot: no
 Temperature range: -25 ... 80 °C (moving)
 -40 ... 80 °C (not moving)
 Bending radius: > 30 mm (fixed installation)
 > 75 mm (dynamic)

Sensor	Cables	Type	Connection possibilities and accessories	
LD1900-xx ILD1900-xxLL ILD1910-xx	Integrated cable length 3 m	Open ends	Supply voltage connection Power supply unit PS2020	
			Interface module of RS422 to USB IF2001/USB IC2001/USB	
			Interface module for Industrial Ethernet connection IF2035-PROFINET IF2035-EIP IF2035-EtherCAT	



Drag-chain suitable connection cables for sensors with pigtail

Cable diameter: 6.7 ±0.2 mm
 Drag chain: yes
 Robot: no
 Temperature range: -25 ... 80 °C (moving) (up to +105 °C for max. 3000 hrs)
 -40 ... 80 °C (not moving)
 Bending radius: > 34 mm (fixed installation)
 > 67 mm (dynamic)
 > 81 mm (drag chain)

Sensor	Cables	Type	Connection possibilities and accessories	
ILD1900-xx ILD1900-xxLL ILD1910-xx	Extension cable pigtail Length 3 m / 6 m / 9 m / 15 m <i>Art. no. Designation</i> 29011218 PC1900-3/OE 29011219 PC1900-6/OE 29011220 PC1900-9/OE 29011221 PC1900-15/OE	Open ends	Connection supply voltage PS2020	
			Interface module of RS422 to USB IF2001/USB IC2001/USB	
			Interface module for Industrial Ethernet connection IF2035-PROFINET IF2035-EIP IF2035-EtherCAT	
			Interface card for synchronous data acquisition IF2008PCIe / IF2008E	
	Adapter cable for PC interface card Length 3 m / 6 m / 9 m / 15 m <i>Art. no. Designation</i> 29011316 PC1900-3/IF2008 PCIE 29011317 PC1900-6/IF2008 PCIE 29011318 PC1900-9/IF2008 PCIE 29011319 PC1900-15/IF2008 PCIE	Sub-D	4-fold interface module from RS422 to USB IF2004/USB	
	Adapter cable for sensor calculation Length 3 m / 6 m / 9 m / 15 m <i>Art. no. Designation</i> 29011320 PC1900-3/C-Box 29011321 PC1900-6/C-Box 29011322 PC1900-9/C-Box 29011323 PC1900-15/C-Box	Sub-D	Controller for D/A conversion and evaluation of up to 2 sensor signals Dual Processing Unit	
	Adapter cable for sensor calculation Length 2 m <i>Art. no. Designation</i> 29011326 PCE1900-3/M12	M12	Interface module for Ethernet connection of up to 8 sensors IF2008/ETH	

Robot-suitable connection cables

Cable diameter:	approx. 7.3 mm
Drag chain:	no
Robot:	yes
Temperature range:	-40 ... 90 °C (moving) -50 ... 90 °C (not moving)
Bending radius:	> 37 mm (fixed installation) > 73 mm (dynamic)

Sensor	Cables	Type	Connection possibilities and accessories
LD1900-xx ILD1900-xxLL	Extension cable pigtail Length 3 m / 6 m / 9 m / 15 m <i>Art. no. Designation</i> 29011404 PC1900R-3/OE 29011405 PC1900R-6/OE 29011406 PC1900R-9/OE 29011407 PC1900R-15/OE	Open ends	Connection supply voltage PS2020 
			Interface module of RS422 to USB IF2001/USB IC2001/USB 
ILD1910-xx			Interface module for Industrial Ethernet connection IF2035-PROFINET IF2035-EIP IF2035-EtherCAT 

Connection cables for sensors with integrated Industrial Ethernet interface



Cable diameter:	7.5 ±0.2 mm
Drag chain:	yes
Robot:	no
Temperature range:	-40 ... 90 °C (moving) -50 ... 90 °C (not moving)
Bending radius:	> 38 mm (fixed installation) > 75 mm (dynamic)

Sensor	Cables	Type	Connection possibilities and accessories
ILD1900-xx-PROFINET* ILD1900-xxLL-PROFINET*	Connection cables PoE, laser On/Off hardware Length 3 m / 6 m / 9 m / 15 m <i>Art. no. Designation</i> 29011332 PC1900-IE-3/OE-RJ45 29011333 PC1900-IE-6/OE-RJ45 29011334 PC1900-IE-9/OE-RJ45 29011444 PC1900-IE-15/OE-RJ45	Open ends & RJ45	Signal / Supply PoE optional: PoE Switch 
ILD1900-xx-EtherCAT ILD1900-xxLL-EtherCAT			
ILD1900-xx-EtherNet/IP ILD1900-xxLL-EtherNet/IP	Connection cables PoE, laser On/Off Software Length 3 m / 6 m / 9 m / 15 m <i>Art. no. Designation</i> 29011338 PC1900-IE-3/RJ45 29011355 PC1900-IE-6/RJ45 29011356 PC1900-IE-9/RJ45 29011445 PC1900-IE-15/RJ45	RJ45	







*PoE not possible with PROFINET

Other cables

Cable diameter:	6.7 mm
Drag chain:	yes
Robot:	no
Temperature range:	-40 ... 80 °C
Bending radius:	> 27 mm (fixed installation) > 51 mm (dynamic)

Input	Cables	Type	Connection possibilities and accessories
2 x Sub-D (PC1900-x/ IF2008 PCIE)	Adapter cable for the connection of two sensors per Sub-D connector Length 0.1 m <i>Art. no. Designation</i> 2901528 IF2008-Y-adapter cable 	Sub-D	Interface card for synchronous data acquisition IF2008PCle / IF2008E 
			4-fold USB converter & parameter setting IF2004/USB 

Highly dynamic laser sensors with high precision optoNCDT 2300

-  For common surfaces
-  Adjustable measuring rate up to 49.14 kHz
-  **INTERFACE** Analog (U/I) / RS422 / Ethernet / EtherCAT / PROFINET / EtherNet/IP
-  **A-RTSC** Advanced Real Time Surface Compensation
-  Resolution 0.03 μm
-  For diffuse and reflective surfaces

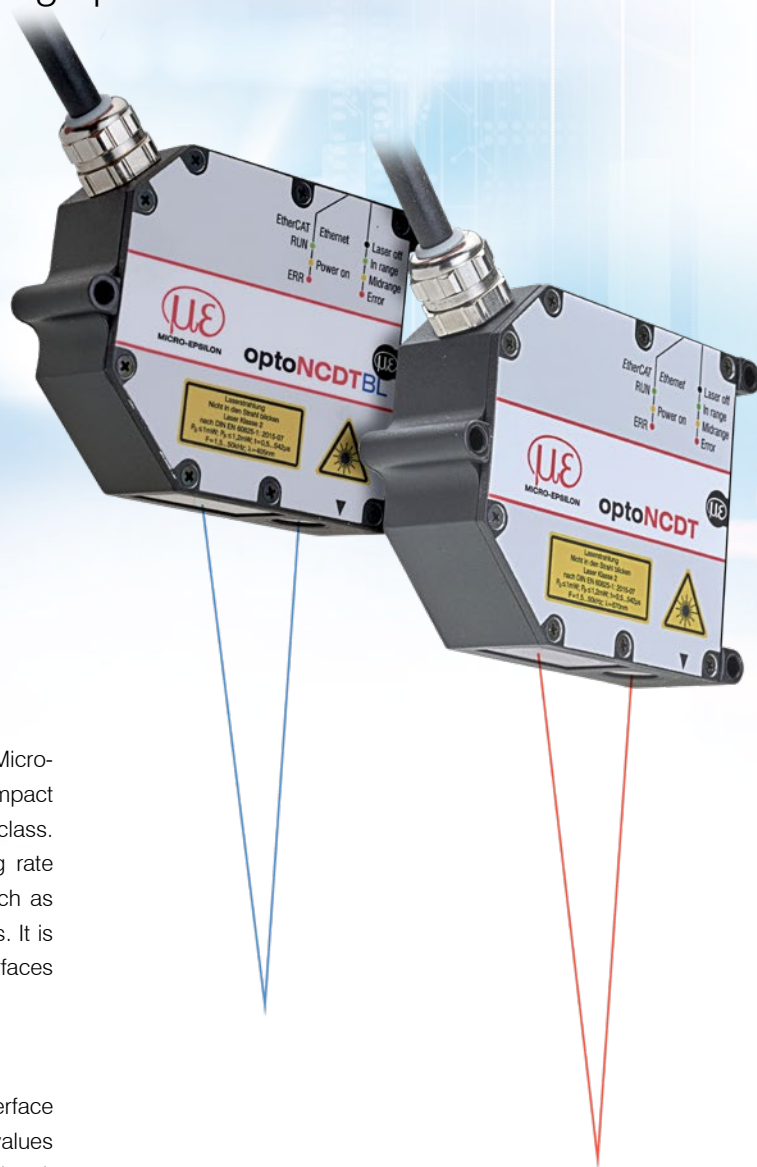





The optoNCDT 2300 sensors form the high-end segment of Micro-Epsilon laser sensors. The entire electronics is integrated in a compact sensor housing which is a worldwide unique feature of this sensor class. The high-precision laser sensor has an adjustable measuring rate of 49.14 kHz and is used for particularly fast applications, such as monitoring vibrations or measurements on challenging surfaces. It is used on diffuse reflective surfaces and for directly reflecting surfaces when equipped with the special alignment feature.

User-friendly web interface for easy operation

The optoNCDT 2300 laser sensors can be operated via a web interface which offers multiple possibilities in order to process measured values and signals, e.g., peak selection, filter and masking of the video signal.

Fast exposure control for demanding surfaces

The new A-RTSC (Advanced Real Time Surface Compensation) feature is a development based on the proven RTSC technology and, with its improved dynamic range, enables more precise real time surface compensation during the measurement process. This means the sensor is not influenced by rapidly changing surface reflections and provides stable measurement results.

Model	Technology	Measuring range	Repeatability	Linearity
optoNCDT 2300		2 - 300 mm	0.03 μm	from 0.02 %
optoNCDT 2300BL		2 - 50 mm	0.03 μm	from 0.02 %
optoNCDT 2300LL		2 - 50 mm	0.1 μm	from 0.02 %
optoNCDT 2300-2DR		2 mm	0.03 μm	from 0.03 %
optoNCDT 2310		10 - 50 mm	0.5 μm	from 0.03 %

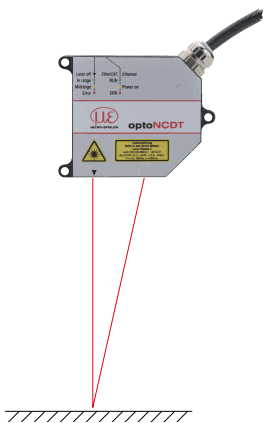

Distance measurement on diffuse reflecting surfaces

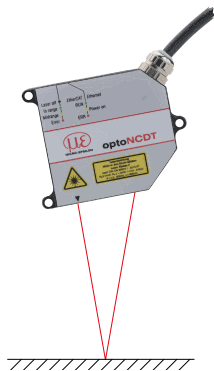

Distance measurement on directly reflecting surfaces

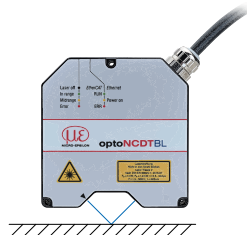

High precision distance measurement on directly reflecting surfaces

Versatile use

The optoNCDT 2300 sensors can be operated in several measurement modes: in standard mode for distance measurement on diffusely reflecting materials. In addition, the sensors can be used for distance measurement on reflective and shiny surfaces (direct reflection).

Application examples

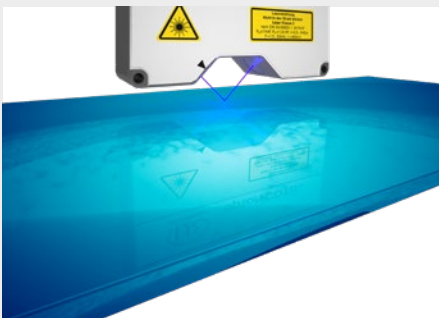

Distance measurement of coated glass

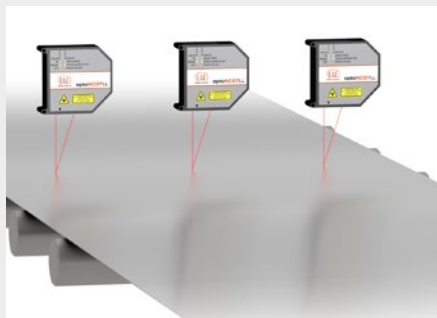

Planarity testing of metal strips



Testing the radial run out of rollers

Technical data

optoNCDT 2300

optoNCDT 2300 (General technical data)

Model	ILD23x0-xx
Measuring rate ^[1]	7 adjustable stages: 49.14 kHz / 30 kHz / 20 kHz / 10 kHz / 5 kHz / 2.5 kHz / 1.5 kHz
Light source	Semiconductor laser < 1 mW, 670 nm (red)
Laser class	Class 2 in accordance with DIN EN 60825-1 : 2022-07 / (optional class 3R)
Permissible ambient light	10,000...40,000 lx
Supply voltage	11 ... 30 VDC
Power consumption	< 3 W (24 V)
Signal input	Laser on/off, sync in, trigger in
Digital interface ^[2]	RS422 (16 bit) / Ethernet / EtherCAT / PROFINET / EtherNet/IP
Analog output ^[3]	4 ... 20 mA / 0 ... 5 V / 0 ... 10 V / ± 5 V / ± 10 V
Synchronization	possible for simultaneous or alternating measurements
Connection	integrated pigtail 0.25 m with 14-pin cable connector, min. bending radius 30 mm when firmly installed; optional extension to 3 m / 6 m / 9 m possible (see accessories for suitable connection cables)
Installation	Screw connection via three mounting holes
Temperature range	Storage -20 ... +70 °C (non-condensing)
	Operation 0 ... +50 °C (non-condensing)
Shock (DIN EN 60068-2-27)	15 g / 6 ms in 3 axes
Vibration (DIN EN 60068-2-6)	2 g / 20 ... 500 Hz
Protection class (DIN EN 60529)	IP65
Weight	approx. 550 g (incl. pigtail)
Control and indicator elements ^[4]	Web interface for setup: user management, measurement settings, data output, measurement control, parameters and extras; 2x color LEDs for status / Ethernet and EtherCAT

^[1] Measuring rate 49.14 kHz with reduced measuring range (in brackets)

^[2] PROFINET and EtherNet/IP require connection via interface module (see accessories)

^[3] Requires connection via interface module (see accessories)

^[4] Access to web interface requires connection to PC via IP2001/USB (see accessories)



Laser-Point - optoNCDT 2300 / Measuring ranges 2 - 20

Model		ILD2300-2	ILD2300-5	ILD2300-10	ILD2300-20
Measuring range ^[1]		2 (2) mm	5 (2) mm	10 (5) mm	20 (10) mm
Start of measuring range ^[1]		24 (24) mm	24 (24) mm	30 (35) mm	40 (50) mm
Mid of measuring range ^[1]		25 (25) mm	26.5 (25) mm	35 (37.5) mm	50 (55) mm
End of measuring range ^[1]		26 (26) mm	29 (26) mm	40 (40) mm	60 (60) mm
Linearity ^[2]		< $\pm 0.6 \mu\text{m}$	< $\pm 1.5 \mu\text{m}$	< $\pm 2 \mu\text{m}$	< $\pm 4 \mu\text{m}$
		< ± 0.03 % FSO	< ± 0.03 % FSO	< ± 0.02 % FSO	< ± 0.02 % FSO
Resolution ^[3]		0.03 μm	0.08 μm	0.15 μm	0.3 μm
Light spot diameter ^[4]	SMR	55 x 85 μm	70 x 80 μm	75 x 85 μm	140 x 200 μm
	MMR	23 x 23 μm	30 x 30 μm	32 x 45 μm	46 x 45 μm
	EMR	35 x 85 μm	70 x 80 μm	110 x 160 μm	140 x 200 μm
Material		Die-cast zinc housing			

^[1] Value in brackets applies for measuring rate 49.14 kHz

^[2] FSO = Full Scale Output

The specified data apply to white, diffuse reflecting surfaces (Micro-Epsilon reference ceramic for ILD sensors)

^[3] Measuring rate 20 kHz

^[4] ± 10 %; SMR = Start of measuring range; MMR = Mid of measuring range; EMR = End of measuring range

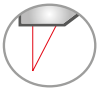

Laser point - optoNCDT 2300 / Measuring ranges 50 - 300

Model		ILD2300-50	ILD2300-100	ILD2300-200	ILD2300-300
Measuring range ^[1]		50 (25) mm	100 (50) mm	200 (100) mm	300 (150) mm
Start of measuring range ^[1]		45 (70) mm	70 (120) mm	130 (230) mm	200 (350) mm
Mid of measuring range ^[1]		70 (82.5) mm	120 (145) mm	230 (280) mm	350 (425) mm
End of measuring range ^[1]		95 (95) mm	170 (170) mm	330 (330) mm	500 (500) mm
Linearity ^[2]		< ±10 μm	< ±20 μm	< ±60 μm	< ±90 μm
		< ±0.02 % FSO	< ±0.02 % FSO	< ±0.03 % FSO	< ±0.03 % FSO
Resolution ^[3]		0.8 μm	1.5 μm	3 μm	4.5 μm
Light spot diameter ^[4]	SMR	255 x 350 μm	350 μm	1300 μm	580 x 860 μm
	MMR	70 x 70 μm	130 μm	1300 μm	380 x 380 μm
	EMR	255 x 350 μm	350 μm	1300 μm	470 x 530 μm
Material		Die-cast zinc housing		Aluminum housing	

^[1] Value in brackets applies for measuring rate 49.14 kHz

^[2] FSO = Full Scale Output

The specified data apply to white, diffuse reflecting surfaces (Micro-Epsilon reference ceramic for ILD sensors)

^[3] Measuring rate 20 kHz

^[4] ±10 %; SMR = Start of measuring range; MMR = Mid of measuring range; EMR = End of measuring range



Blue laser - optoNCDT 2300BL

Model		ILD2300-2BL	ILD2300-5BL	ILD2300-10BL	ILD2310-50BL
Measuring range ^[1]		2 (2) mm	5 (2)	10 (5) mm	50 (25) mm
Start of measuring range ^[1]		24 (24) mm	24 (24) mm	30 (35) mm	550 (575) mm
Mid of measuring range ^[1]		25 (25) mm	26.5 (25) mm	35 (37.5) mm	575 (587.5) mm
End of measuring range ^[1]		26 (26) mm	29 (26) mm	40 (40) mm	600 (600) mm
Linearity		< ±0.6 μm	< ±1.5 μm	< ±2 μm	< ±40 μm
		< ±0.03 % FSO	< ±0.03 % FSO	< ±0.02 % FSO	< ±0.08 % FSO
Resolution ^[2]		0.03 μm	0.08 μm	0.15 μm	7.5 μm
Light spot diameter ^[3]	SMR	70 x 80 μm	200 x 200 μm	75 x 85 μm	400 ... 500 μm
	MMR	20 x 20 μm	20 x 20 μm	32 x 45 μm	
	EMR	80 x 100 μm	200 x 400 μm	110 x 160 μm	
Light source		Semiconductor laser < 1 mW, 405 nm (blue violet)			
Permissible ambient light		10,000 lx			

^[1] Value in brackets applies for measuring rate 49.14 kHz

^[2] Measuring rate 20 kHz

^[3] ±10 %; SMR = Start of measuring range; MMR = Mid of measuring range; EMR = End of measuring range

Technical data

optoNCDT 2300



Laser-Line - optoNCDT 2300LL

Model		ILD2300-2LL	ILD2300-10LL	ILD2300-20LL	ILD2300-50LL
Measuring range ^[1]		2 (2) mm	10 (5) mm	20 (10) mm	50 (25) mm
Start of measuring range ^[1]		24 (24) mm	30 (35) mm	40 (50) mm	45 (70) mm
Mid of measuring range ^[1]		25 (25) mm	35 (37.5) mm	50 (55) mm	70 (82.5) mm
End of measuring range ^[1]		26 (26) mm	40 (40) mm	60 (60) mm	95 (95) mm
Linearity ^[2]		< ±0.6 μm	< ±2 μm	< ±4 μm	< ±10 μm
		< ±0.03 % FSO	< ±0.02 % FSO	< ±0.02 % FSO	< ±0.02 % FSO
Resolution ^[3]		0.03 μm	0.15 μm	0.3 μm	0.8 μm
Light spot diameter ^[4]	SMR	85 x 240 μm	120 x 405 μm	185 x 485 μm	350 x 320 μm
	MMR	24 x 280 μm	35 x 585 μm	55 x 700 μm	70 x 960 μm
	EMR	64 x 400 μm	125 x 835 μm	195 x 1200 μm	300 x 1940 μm
Material		Die-cast zinc housing			

^[1] Value in brackets applies for a measuring rate of 49.14 kHz

^[2] FSO = Full Scale Output

The specified data apply to white, diffuse reflecting surfaces (Micro-Epsilon reference ceramic for ILD sensors)

^[3] Measuring rate 20 kHz

^[4] ±10 %; SMR = Start of measuring range; MMR = Mid of measuring range; EMR = End of measuring range



Direct reflection - optoNCDT 2300-2DR

Model		ILD2300-2DR/BL
Measuring range ^[1]		2 (1) mm
Start of measuring range ^[1]		9 (9) mm
Mid of measuring range ^[1]		10 (9.5) mm
End of measuring range ^[1]		11 (10) mm
Linearity ^[2]		< ±0.6 μm
		< ±0.03 % FSO
Resolution ^[3]		0.03 μm
Temperature stability ^[4]		±0.01 % FSO / K
Light spot diameter ^[5]	SMR	21.6 x 25 μm
	MMR	8.5 x 11 μm
	EMR	22.4 x 23.7 μm
Light source		Semiconductor laser <1 mW, 405 nm (blue violet)
Power consumption		< 2 W (24 V)
Connection		integrated pigtail 0.25 m with 14-pin cable connector, min. bending radius 30 mm when firmly installed; optional extension to 3 m / 10 m possible (see accessories for suitable connection cables)
Material		Aluminum housing
Weight		approx. 400 g (incl. pigtail)

^[1] Value in brackets applies for a measuring rate of 49.14 kHz

^[2] The specified data apply to directly reflecting surfaces; FSO = Full Scale Output

^[3] Measuring rate 20 kHz

^[4] Relates to digital output in mid of measuring range

^[5] ±10 %; SMR = Start of measuring range; MMR = Mid of measuring range; EMR = End of measuring range

Light spot diameter determined with point-shaped laser with Gaussian fit (full 1/e² width)



Laser-Point - optoNCDT 2310

Model	ILD2310-10	ILD2310-20	ILD2310-40	ILD2310-50
Measuring range ^[1]	10 (5) mm	20 (10) mm	40 (20) mm	50 (25) mm
Start of measuring range ^[1]	95 (100) mm	90 (100) mm	175 (195) mm	550 (575) mm
Mid of measuring range ^[1]	100 (102.5) mm	100 (105) mm	195 (205) mm	575 (587.5) mm
End of measuring range ^[1]	105 (105) mm	110 (110) mm	215 (215) mm	600 (600) mm
Linearity ^[2]	< ±3 μm	< ±6 μm	< ±12 μm	< ±50 μm
	< ±0.03 % FSO	< ±0.03 % FSO	< ±0.03 % FSO	< ±0.1 % FSO
Resolution ^[3]	0.5 μm	1 μm	2 μm	7.5 μm
Light spot diameter ^[4]	SMR	200 μm	230 μm	400 ... 500 μm
	MMR	60 μm	210 μm	
	EMR	200 μm	230 μm	
Connection	integrated pigtail 0.25 m with 14-pin ODU plug, min. bending radius 30 mm when firmly installed (see accessories for suitable connection cable)			
Material	Aluminum housing			

^[1] Value in brackets applies for measuring rate 49.14 kHz

^[2] FSO = Full Scale Output

The specified data apply to white, diffuse reflecting surfaces (Micro-Epsilon reference ceramic for ILD sensors)

^[3] with 10 kHz, without averaging

^[4] ± 10 %; SMR = Start of measuring range; MMR = Mid of measuring range; EMR = End of measuring range

Dimensions

optoNCDT 2300

optoNCDT 2300 / Measuring range 2 - 100

optoNCDT 2300-2 ... 2300-100
Diffuse reflection

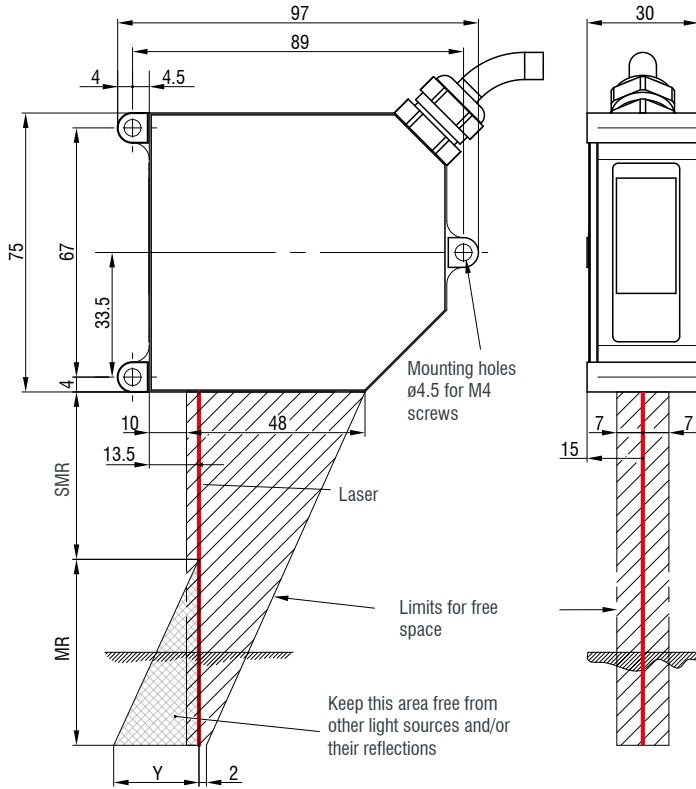

optoNCDT 2300-2 ... 2300-20
Direct reflection

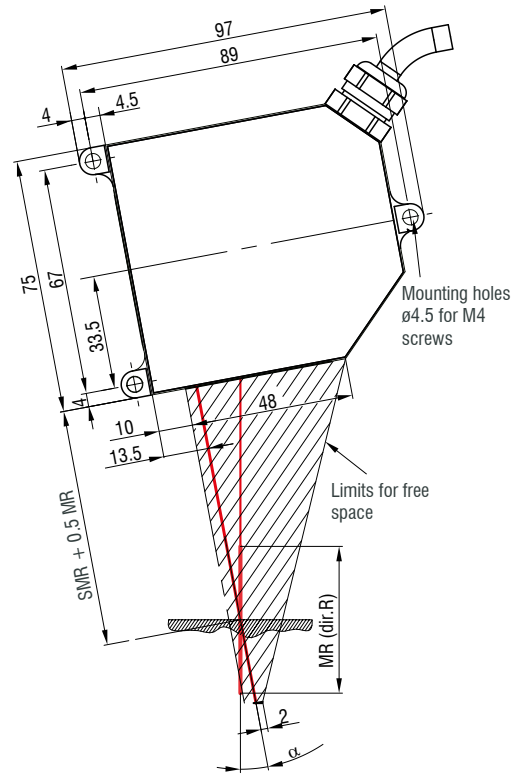

optoNCDT 2300 (Diffuse reflection)
optoNCDT 2300LL
optoNCDT 2300BL (Diffuse reflection)

MR	SMR	Y
2	24	1.5
5	24	3.5
10	30	6.5
20	40	10.0
50	45	23.0
100	70	33.5

optoNCDT 2300 (Direct reflection)
optoNCDT 2300BL (Direct reflection)

MR	SMR + 0.5 MR	α
2	25	20.5 °
5	26.5	20 °
10	35	17.5 °
20	50	13.8 °

Connector (sensor side)

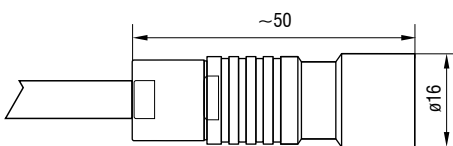

optoNCDT 2300 / Measuring ranges 200/300

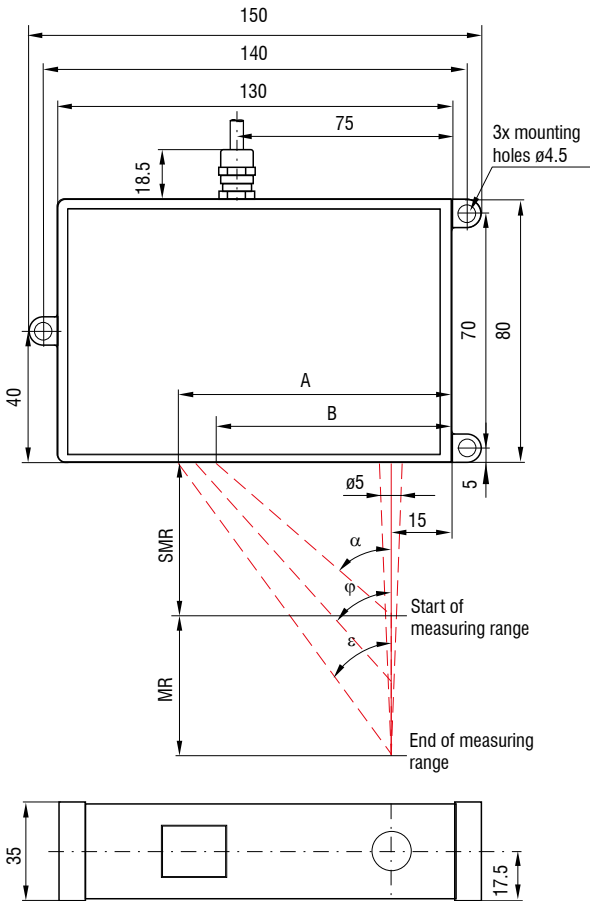

optoNCDT 2300BL / Measuring range 50
optoNCDT 2310 / Measuring range 50

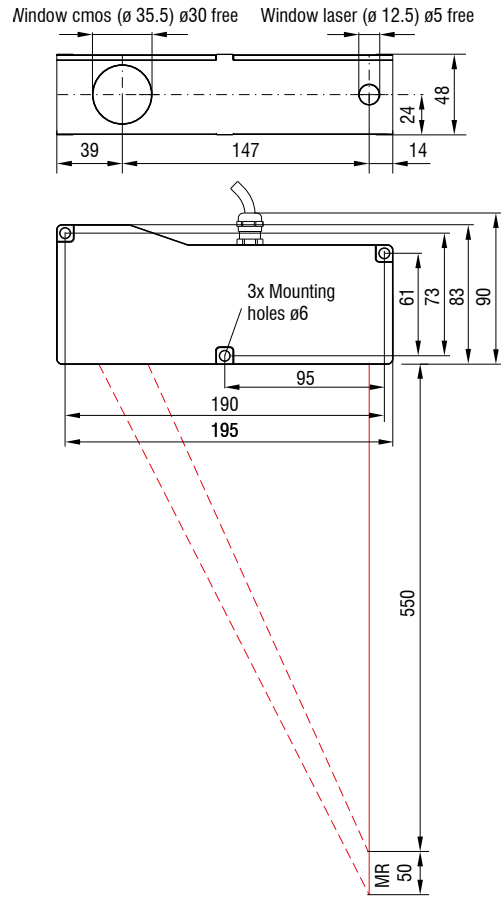

MR	α	φ	ε	A	B
200	25.1 °	16.7 °	13.1 °	91.6	76
300	18.3 °	12.2 °	9.6 °	99.4	81

(Dimensions in mm, not to scale)

MR = measuring range; SMR = start of measuring range

MMR = mid of measuring range; EMR = end of measuring range

Connector (sensor side)

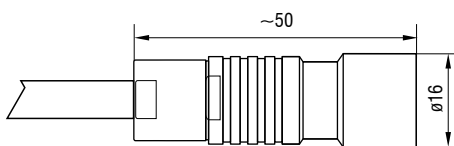

Dimensions

optoNCDT 2300

optoNCDT 2310 / Measuring ranges 10/20/40

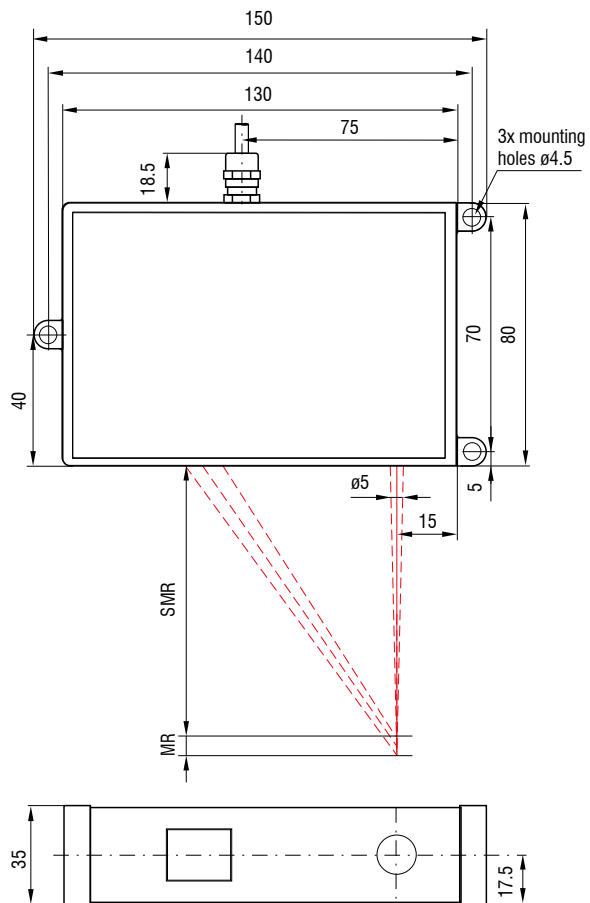

optoNCDT 2300-2DR

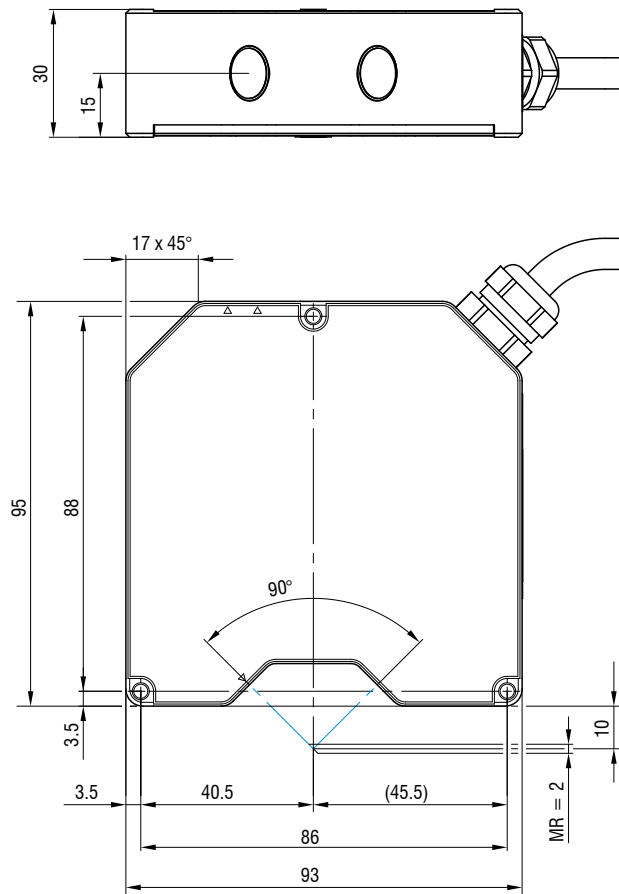

MR	SMR	MMR	EMR
10	95	100	105
20	90	100	110
40	175	195	215

(Dimensions in mm, not to scale)

MR = measuring range; SMR = start of measuring range

MMR = mid of measuring range; EMR = end of measuring range

Connector (sensor side)

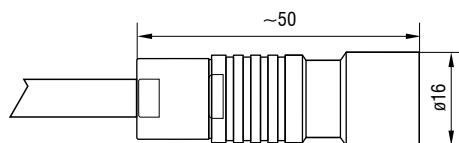

Installation options

Housings M and L

Bolt connection

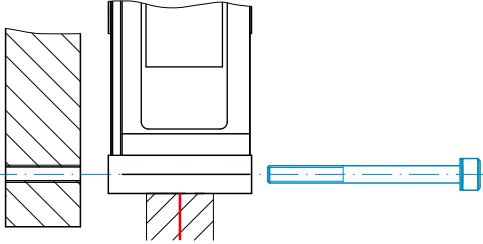

ILD2300-2 ... ILD2300-100 ILD2300BL / ILD2300LL	M4
ILD2300-200 / -300 ILD2310-10 / -20 / -40	M4
ILD2310-50 ILD2310-50BL	M5
ILD2300-2DR	M3

Direct fastening

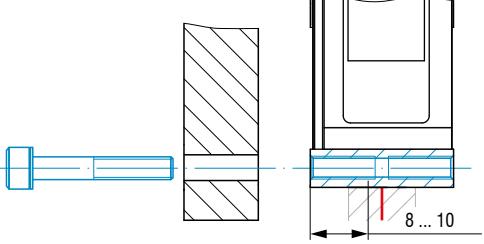

ILD2300-2 ... ILD2300-100 ILD2300BL / ILD2300LL	-
ILD2300-200 / -300 ILD2310-10 / -20 / -40	M5
ILD2310-50 ILD2310-50BL	M6
ILD2300-2DR	M4

Accessories for optoNCDT 2300/2310

Power supply unit

PS2020 (power supply 24 V / 2.5 A, input 100 - 240 VAC, output 24 VDC / 2.5 A, mounting onto symmetrical standard rail 35 mm x 7.5 mm, DIN 50022)

Mounting plate

for easy alignment of the DR models

Protective housings

see page 62

Article designation

ILD2300-	6	LL	3R
Laser class No indication: class 2 (standard) 3R: class 3R (on request)			
Laser type No indication: Red laser point (standard) LL: Laser Line BL: Blue Laser DR: Direct Reflection			
Measuring range in mm			
Series ILD2300: Highly dynamic laser sensor in the 50 kHz class ILD2310: Laser sensors with small measuring range and large offset distance			

Scope of supply

- 1 sensor ILD23x0 with 0.25 m connection cable and cable socket
- 2 laser warning signs according to IEC standard
- RJ45 short-circuit plug

Connection possibilities

optoNCDT 2300



Drag-chain suitable extension and adapter cables

Cable diameter: max. 7.5 mm
 Drag chain: ja
 Robot: no
 Temperature range: -40 ... 70 °C (moving / not moving)
 Bending radius: > 90 mm (fixed installation / dynamic / drag chain)

Sensor	Cables	Type	Connection possibilities and accessories
ILD2300-xx ILD2300-xxLL ILD2300-xxBL ILD2300-2DR ILD2310-xx	Extension cable pigtail Length 3 m / 6 m / 9 m / 15 m <i>Art. no.</i> <i>Designation</i> 2901717 PC2300-3/OE 2901760 PC2300-6/OE 2901761 PC2300-9/OE 2901762 PC2300-15/OE	Open ends	Supply voltage connection Power supply unit PS2020 Interface module of RS422 to USB IF2001/USB Interface module for Industrial Ethernet connection IF2035-PROFINET IF2035-EIP IF2035-EtherCAT
	Adapter cable for PC interface card Length 3 m / 6 m <i>Art. no.</i> <i>Designation</i> 2901728 PC2300-3/IF2008 2901729 PC2300-6/IF2008	Sub-D	Interface card for synchronous data acquisition IF2008PCIe / IF2008E 4-fold interface module from RS422 to USB IF2004/USB
	Adapter cable for sensor calculation Length 3 m / 6 m / 9 m <i>Art. no.</i> <i>Designation</i> 29011031 PC2300-3/C-Box/RJ45 29011044 PC2300-6/C-Box/RJ45 29011045 PC2300-9/C-Box/RJ45	Sub-D	Controller for D/A conversion and evaluation of up to 2 sensor signals Dual Processing Unit
	Adapter cable for sensor calculation Length 2 m <i>Art. no.</i> <i>Designation</i> 29011279 PCE2300-3/M12	M12	Interface module for Ethernet connection of up to 8 sensors IF2008/ETH
	Adapter cable Sub-D for EtherCAT Length 3 m / 6 m <i>Art. no.</i> <i>Designation</i> 2901661 PC2300-3/SUB-D 2901976 PC2300-6/SUB-D	Sub-D	Signal output Ethernet, EtherCAT, RS422 to PC or PLC PC2300-0,5Y Connection cable ILD2300





Connection cable for high temperature

Cable diameter:	max. 7.5 mm
Drag chain:	no
Robot:	no
Temperature range:	-55 ... 250 °C (moving) -90 ... 250 °C (not moving)
Bending radius:	> 40 mm (fixed installation) > 75 mm (dynamic)

Sensor	Cables	Type	Connection possibilities and accessories	
ILD2300-xx ILD2300-xxLL ILD2300-xxBL ILD2300-2DR ILD2310-xx	Connection cable high temperatures Length 3 m / 6 m / 9 m / 15 m <i>Art. no.</i> <i>Designation</i> 29011118 PC2300-3/OE/HT 29011119 PC2300-6/OE/HT 29011095 PC2300-9/OE/HT 29011120 PC2300-15/OE/HT	Open ends	Connection supply voltage PS2020	
			Interface module of RS422 to USB IF2001/USB	
			Interface module for Industrial Ethernet connection IF2035-PROFINET IF2035-EIP IF2035-EtherCAT	





Connection cable for EtherCAT operation

Cable diameter:	max. 7.5 mm
Drag chain:	yes
Robot:	no
Temperature range:	-40 ... 70 °C (moving / not moving)
Bending radius:	> 90 mm (fixed installation / dynamic / drag chain)

Input	Cables	Type	Connection possibilities and accessories	
Sub-D (PC2300-x/ Sub-D)	Adapter cable for EtherCAT Length 0.5 m <i>Art. no.</i> <i>Designation</i> 2901693 PC2300-0,5Y Connection cable ILD2300 	Open ends & RJ45	Signal output EtherCAT & Ethernet	
			Supply voltage connection Power supply unit PS2020	
			Interface module of RS422 to USB IF2001/USB	

Powerful laser sensors for special applications

optoNCDT 17x0 / optoNCDT 1910

-  Adjustable measuring rate up to 10 kHz
-  Analog (U/I) / RS422 / PROFINET / EtherNet/IP
-  Fast surface compensation
-  High repeatability
-  Ideal for large measurement distances

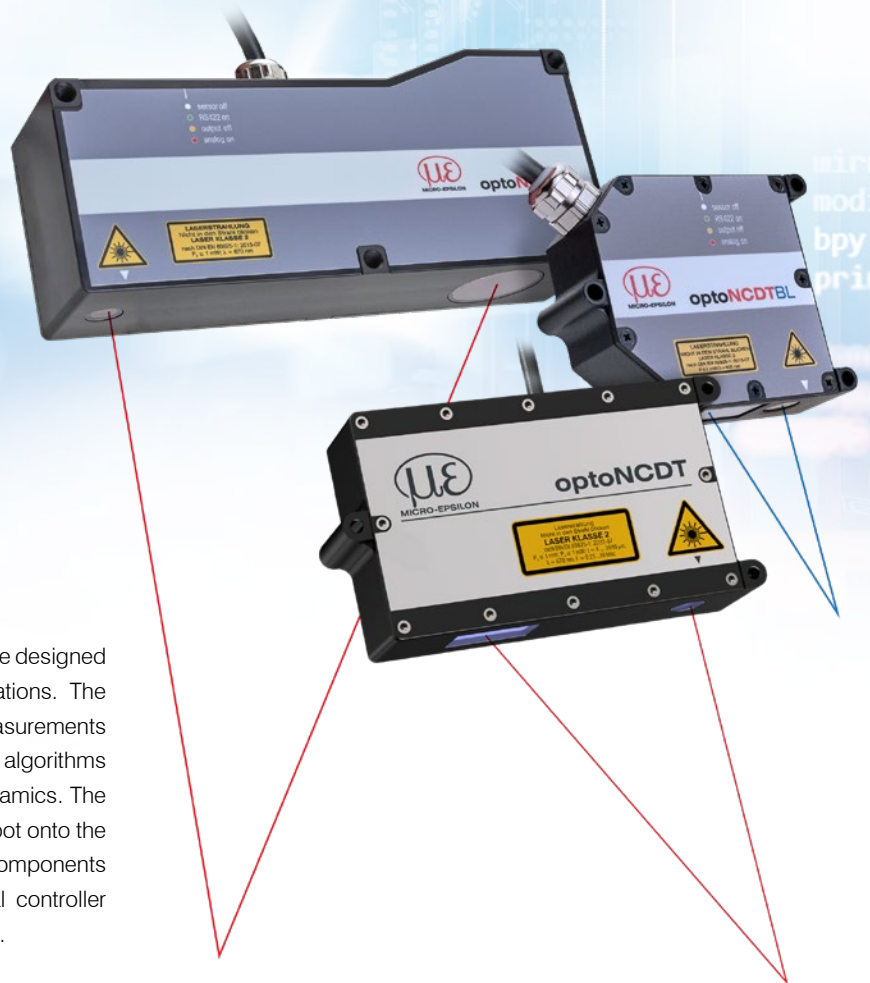







The optoNCDT 1910, 1710 and 1750 series laser sensors are designed for fast and precise measurements in industrial applications. The models are used for demanding surfaces and impress in measurements where large distances are required. Innovative evaluation algorithms and improved components enable high accuracy and dynamics. The high-performance optical system generates a small light spot onto the target which enables the detection of even the smallest of components reliably. The pigtail cable in conjunction with the internal controller reduces the installation effort for the sensors to a minimum.

The intelligent exposure control for demanding surfaces

The optoNCDT 1750 sensors feature real-time surface compensation. The real-time surface compensation feature (RTSC) determines the amount of reflection from the target surface during continuous exposure and in real-time. The exposure time or the amount of light produced by the laser is optimally matched to the reflection characteristics of the target surface. This enables extremely reliable measurements even on reflecting surfaces. The optoNCDT 1910 sensors use Advanced Surface Compensation and are also highly resistant to ambient light.

Ideal for industrial applications

Different output signals enable the integration of the sensor into plant and machine control systems. As well as analog voltage and current outputs, a digital interface provides distance information from the sensor. Due to the universal setting and evaluation possibilities, the sensors meet all the requirements for use in industrial applications.

Model	Technology	Measuring range	Repeatability	Linearity
optoNCDT 1750BL		2 - 750 mm	0.8 μm	from 0.06 %
optoNCDT 1750-DR		2 - 20 mm	0.1 μm	0.08 %
optoNCDT 1710		50 mm	from 7.5 μm	0.10 %
optoNCDT 1710BL		50 / 1000 mm	7.5 μm	from 0.10 %
optoNCDT 1760		1000 mm	from 7.5 μm	0.10 %
optoNCDT 1910		500 / 750 mm	from 20 μm	0.07 %

Large distance and large measuring range

The optoNCDT long-range models are used to cover a large measuring range or to measure from a large distance to the target. The long-range laser sensors combine high accuracy and large measuring distances.

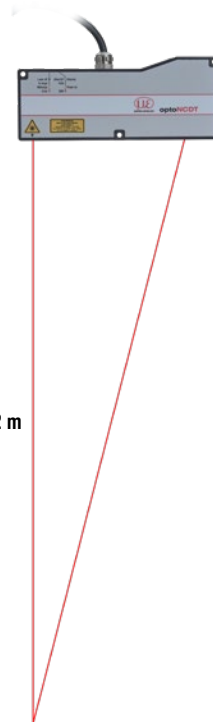

Measurement distances up to 2 m

Application examples

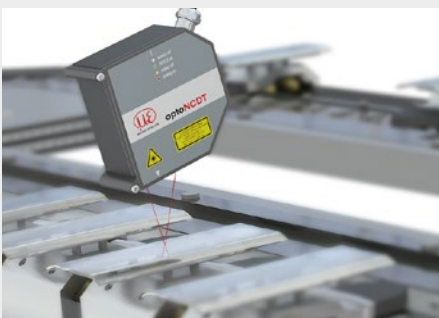

Geometry testing of reflective glass parts

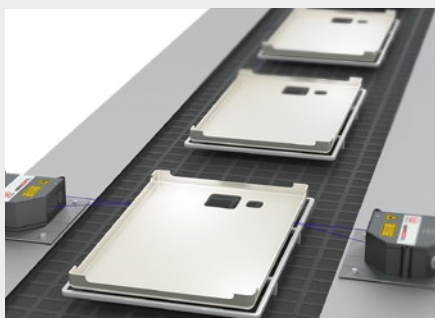

Position check of plastic components

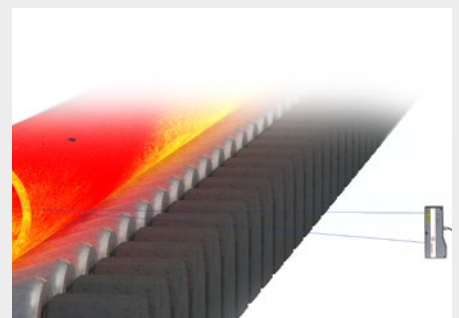

Position measurement of red-hot glowing pipes

Technical data

optoNCDT 17x0 Laser sensors for demanding objects

optoNCDT 1750 (General technical data)

Model	ILD1750-xx	
Measuring rate ^[1]	6 adjustable stages: 7.5 kHz / 5 kHz / 2.5 kHz / 1.25 kHz / 625 Hz / 300 Hz	
Light source	Semiconductor laser < 1 mW, 670 nm (red)	
Laser class	Class 2 in accordance with DIN EN 60825-1: 2022-07	
Permissible ambient light	10,000 lx	
Supply voltage	11 ... 30 VDC	
Power consumption	< 3 W (24 V)	
Signal input	1 x HTL/TTL laser on/off; 1 x HTL/TTL multi-function input: trigger in, slave in, zero setting, mastering, teach-in; 1 x RS422 synchronization input: trigger in, sync in, master/slave, master/slave alternating	
Digital interface ^[2]	RS422 (16 bit) / EtherCAT / PROFINET / EtherNet/IP	
Analog output	4 ... 20 mA / 0 ... 5 V / 0 ... 10 V (16 bit, freely scalable within the measuring range)	
Switching output	2x switching outputs (error & limit value): npn, pnp, push pull	
Connection	integrated pigtail 0.25 m with 14-pin ODU connector, min. bending radius 30 mm when firmly installed; optional extension to 3 m / 10 m possible (see accessories for suitable connection cables)	
Installation	Screw connection via three mounting holes	
Temperature range	Storage	-20 ... +70 °C (non-condensing)
	Operation	0 ... +50 °C (non-condensing)
Shock (DIN EN 60068-2-27)	15 g / 6 ms in 3 axes	
Vibration (DIN EN 60068-2-6)	2 g / 20 ... 500 Hz	
Protection class (DIN EN 60529)	IP65	
Material	Zinc die-cast housing	
Weight	approx. 550 g (incl. pigtail)	
Control and indicator elements ^[3]	Select & function keys: interface selections, mastering (zero), teach, presets, quality slider, frequency selection, factory settings; web interface for setup: application-specific presets, peak selection, video signal, freely selectable averaging possibilities, data reduction, setup management 2 x color LEDs for power / status	

^[1] Factory setting: measuring rate 4 kHz, modifying the factory setting requires the IF2001/USB converter (see accessories)

^[2] EtherCAT, PROFINET and EtherNet/IP require connection via interface module (see accessories)

^[3] Access to web interface requires connection to PC via IF2001/USB (see accessories)



Blue laser - optoNCDT 1750BL

Model		ILD1750-20BL	ILD1750-200BL	ILD1750-500BL	ILD1750-750BL
Measuring range		20 mm	200 mm	500 mm	750 mm
Start of measuring range		40 mm	100 mm	200 mm	200 mm
Mid of measuring range		50 mm	200 mm	450 mm	575 mm
End of measuring range		60 mm	300 mm	700 mm	950 mm
Linearity ^[1]		< ±12 μm	< ±160 μm	< ±350 μm	< ±670 μm
		< ±0.06 % FSO	< ±0.08 % FSO	< ±0.07 % FSO	< ±0.09 % FSO
Repeatability ^[2]		0.8 μm	15 μm	20 μm	45 μm
Light spot diameter ^[3]	SMR	320 μm	1300 μm	1500 μm	1500 μm
	MMR	45 μm			
	EMR	320 μm			
Light source	Semiconductor laser <1 mW, 405 nm (blue violet)				
Material	Die-cast zinc housing			Aluminum housing	

^[1] FSO = Full Scale Output; the specified data apply to white, diffuse reflecting surfaces (Micro-Epsilon reference ceramic for ILD sensors)

^[2] Measuring rate 5 kHz, median 9

^[3] ±10 %; SMR = Start of measuring range; MMR = Mid of measuring range; EMR = End of measuring range



Direct reflection - optoNCDT 1750DR

Model		ILD1750-2DR	ILD1750-10DR	ILD1750-20DR
Measuring range		2 mm	10 mm	20 mm
Start of measuring range		24 mm	30.5 mm	53.5 mm
Mid of measuring range		25 mm	35.5 mm	63.5 mm
End of measuring range		26 mm	40.5 mm	73.5 mm
Linearity ^[1]		< ±1.6 μm	< ±6 μm	< ±12 μm
		< ±0.08 % FSO		
Repeatability ^[2]		0.1 μm	0.4 μm	0.8 μm
Measuring angle		20°	17.6°	11.5°
Light spot diameter ^[3]	SMR	80 μm	110 μm	320 μm
	MMR	35 μm	50 μm	45 μm
	EMR	80 μm	110 μm	320 μm

^[1] FSO = Full Scale Output; the specified data apply to white, diffuse reflecting surfaces (Micro-Epsilon reference ceramic for ILD sensors)

^[2] Measuring rate 5 kHz, median 9

^[3] ±10 %; SMR = Start of measuring range; MMR = Mid of measuring range; EMR = End of measuring range

Technical data

optoNCDT 17x0 Laser sensors for large measuring ranges



Long range - optoNCDT 1710

Model		ILD1710-50
Measuring range		50 mm
Start of measuring range		550 mm
Mid of measuring range		575 mm
End of measuring range		600 mm
Measuring rate		4 adjustable stages: 2.5 kHz / 1.25 kHz / 625 Hz / 312.5 Hz
Linearity ^[1]		< ±50 μm < ±0.1 % FSO
Resolution ^[2]		7.5 μm
Light spot diameter ^[3]	SMR	400 x 500 μm
	MMR	
	EMR	
Light source		Semiconductor laser < 1 mW, 670 nm (red)
Laser class		Class 2 in accordance with DIN EN 60825-1: 2022-07
Permissible ambient light		10,000 lx
Supply voltage		11 ... 30 VDC
Max. current consumption		150 mA (24 V)
Signal input		Zero, laser on/off
Digital interface		RS422 (14 bit)
Analog output		4 ... 20 mA / 0 ... 10 V
Switching output		1 x error / 2 x limit values (configurable)
Connection		integrated pigtail 0.25 m with 14-pin ODU plug, min. bending radius 30 mm when firmly installed (see accessories for suitable connection cable)
Installation		Screw connection via three mounting holes
Temperature range	Storage	-20 ... +70 °C (non-condensing)
	Operation	0 ... +50 °C (non-condensing)
Shock (DIN EN 60068-2-27)		15 g / 6 ms in 3 axes
Vibration (DIN EN 60068-2-6)		2 g / 20 ... 500 Hz
Protection class (DIN EN 60529)		IP65
Material		Aluminum housing
Weight		approx. 800 g (incl. pigtail)
Control and display elements		Select & function keys: output type, measuring rate, type of averaging, averaging number, error analog, synchronization, operation mode, trigger mode, baud rate, data format; display of measured values via PC with sensorTOOL; 5x color LEDs for status display

^[1] FSO = Full Scale Output; the specified data apply to white, diffuse reflecting surfaces (Micro-Epsilon reference ceramic for ILD sensors)

^[2] Measuring rate 2.5 kHz, without averaging

^[3] ±10 %; SMR = Start of measuring range; MMR = Mid of measuring range; EMR = End of measuring range



Long range / Blue laser - optoNCDT 1710BL

Model		ILD1710-50BL	ILD1710-1000BL
Measuring range		50 mm	1 000 mm
Start of measuring range		550 mm	1 000 mm
Mid of measuring range		575 mm	1 500 mm
End of measuring range		600 mm	2 000 mm
Measuring rate		4 adjustable stages: 2.5 kHz / 1.25 kHz / 625 Hz / 312.5 Hz	
Linearity ^[1]		< ±50 μm	< ±1000 μm
		< ±0.1 % FSO	
Resolution ^[2]		7.5 μm	100 μm
Light spot diameter ^[3]	SMR	400 x 500 μm	2500 ... 5000 μm
	MMR		
	EMR		
Light source		Semiconductor laser <1 mW, 405 nm (blue violet)	
Laser class		Class 2 in accordance with DIN EN 60825-1: 2022-07	
Permissible ambient light		10,000 lx	
Supply voltage		11 ... 30 VDC	
Max. current consumption		150 mA (24 V)	
Signal input		Zero, laser on/off	
Digital interface		RS422 (14 bit)	
Analog output		4 ... 20 mA / 0 ... 10 V	
Switching output		1 x error / 2 x limit values (configurable)	
Connection		integrated pigtail 0.25 m with 14-pin ODU plug, min. bending radius 30 mm when firmly installed (see accessories for suitable connection cable)	
Installation		Screw connection via three mounting holes	
Temperature range	Storage	-20 ... +70 °C (non-condensing)	
	Operation	0 ... +50 °C (non-condensing)	
Shock (DIN EN 60068-2-27)		15 g / 6 ms in 3 axes	
Vibration (DIN EN 60068-2-6)		2 g / 20 ... 500 Hz	
Protection class (DIN EN 60529)		IP65	
Material		Aluminum housing	
Weight		approx. 800 g (incl. pigtail)	
Control and display elements		Select & function keys: output type, measuring rate, type of averaging, averaging number, error analog, synchronization, operation mode, trigger mode, baud rate, data format; display of measured values via PC with sensorTOOL; 5x color LEDs for status display	

^[1] FSO = Full Scale Output; the specified data apply to white, diffuse reflecting surfaces (Micro-Epsilon reference ceramic for ILD sensors)

^[2] Measuring rate 2.5 kHz, without averaging

^[3] ±10 %; SMR = Start of measuring range; MMR = Mid of measuring range; EMR = End of measuring range

Technical data

optoNCDT 17x0 Laser sensors for large measuring ranges



Long-Range - optoNCDT 1760

Model		ILD1760-1000
Measuring range		1 000 mm
Start of measuring range		1 000 mm
Mid of measuring range		1 500 mm
End of measuring range		2 000 mm
Measuring rate ^[1]		6 adjustable stages: 7.5 kHz / 5 kHz / 2.5 kHz / 1.25 kHz / 625 Hz / 300 Hz
Linearity ^[2]		< ±1000 µm
		< ±0.1 % FSO
Repeatability ^[3]		100 µm
Light spot diameter ^[4]	SMR	2500 ... 5000 µm
	MMR	
	EMR	
Light source		Semiconductor laser < 1 mW, 670 nm (red)
Laser class		Class 2 in accordance with DIN EN 60825-1: 2022-07
Permissible ambient light		10,000 lx
Supply voltage		11 ... 30 VDC
Max. current consumption		150 mA (24 V)
Signal input		1 x HTL/TTL laser on/off; 1 x HTL/TTL multi-function input: trigger in, slave in, zero setting, mastering, teach-in; 1 x RS422 synchronization input: trigger in, sync in, master/slave, master/slave alternating
Digital interface ^[5]		RS422 (16 bit) / EtherCAT / PROFINET / EtherNet/IP
Analog output		4 ... 20 mA / 0 ... 5 V / 0 ... 10 V (16 bit, freely scalable within the measuring range)
Switching output		2x switching outputs (error & limit value): npn, pnp, push pull
Connection		integrated pigtail 0.25 m with 14-pin ODU connector, min. bending radius 30 mm when firmly installed; optional extension to 3 m / 10 m possible (see accessories for suitable connection cables)
Installation		Screw connection via three mounting holes
Temperature range	Storage	-20 ... +70 °C (non-condensing)
	Operation	0 ... +50 °C (non-condensing)
Shock (DIN EN 60068-2-27)		15 g / 6 ms in 3 axes
Vibration (DIN EN 60068-2-6)		2 g / 20 ... 500 Hz
Protection class (DIN EN 60529)		IP65
Material		Aluminum housing
Weight		approx. 800 g (incl. pigtail)
Control and indicator elements ^[6]		Select & function keys: interface selections, mastering (zero), teach, presets, quality slider, frequency selection, factory settings; web interface for setup: application-specific presets, peak selection, video signal, freely selectable averaging possibilities, data reduction, setup management 2 x color LEDs for power / status

^[1] Factory setting 5 kHz, modifying the factory setting requires the IF2001/USB converter (see accessories)

^[2] FSO = Full Scale Output; the specified data apply to white, diffuse reflecting surfaces (Micro-Epsilon reference ceramic for ILD sensors)

^[3] Measuring rate 5 kHz, median 9

^[4] ±10 %; SMR = Start of measuring range; MMR = Mid of measuring range; EMR = End of measuring range

^[5] EtherCAT, PROFINET and EtherNet/IP require connection via interface module (see accessories)

^[6] Access to web interface requires connection to PC via IF2001/USB (see accessories)

Technical data

optoNCDT 1910 Laser sensors for large measuring ranges



optoNCDT 1910

Model	ILD1910-500	ILD1910-750
Measuring range	500 mm	750 mm
Start of measuring range	200 mm	200 mm
Mid of measuring range	450 mm	575 mm
End of measuring range	700 mm	950 mm
Measuring rate ^[1]	continuously adjustable between 0.25 ... 9.5 kHz or 7 adjustable stages: 9.5 kHz / 8 kHz / 4 kHz / 2 kHz / 1.0 kHz / 500 Hz / 250 Hz	
Linearity ^[2]	< ±0.07 % FSO	±0.08 % FSO
	±350 μm	±600 μm
Repeatability ^[3]	20 μm	30 μm
Light spot diameter ^[4]	800 x 800 μm	1100 x 1100 μm
Light source	Semiconductor laser ≤ 1 mW, 670 nm (red) with laser class 2	
Laser class	Class 2 in accordance with IEC 60825-1: 2014 (Class 3 available on request)	
Permissible ambient light ^[5]	10,000 lx	
Supply voltage	11 ... 30 VDC	
Power consumption	< 3 W (24 V)	
Signal input	1 x HTL/TTL laser on/off; 1 x HTL/TTL multi-function input: trigger in, slave in, zero setting, mastering, teach-in; 1 x RS422 synchronization input: trigger in, sync in, master/slave, master/slave alternating	
Digital interface ^[6]	RS422 (18 bit) / EtherCAT / PROFINET / EtherNet/IP	
Analog output	4 ... 20 mA / 0 ... 5 V / 0 ... 10 V (16 bit, freely scalable within the measuring range)	
Switching output	2x switching outputs (error & limit value): npn, pnp, push pull	
Connection	integrated pigtail 0.3 m with 17-pin M12 plug; optional extension to 3 m / 6 m / 9 m / 15 m possible (suitable connection cable see Accessories)	
Temperature range	Storage	-20 ... +70 °C (non-condensing)
	Operation	0 ... +50 °C (non-condensing)
Shock (DIN EN 60068-2-27)	15 g / 6 ms in 3 axes	
Vibration (DIN EN 60068-2-6)	2 g / 20 ... 500 Hz	
Protection class (DIN EN 60529)	IP65	
Material	Aluminum housing	
Weight	approx. 600 g (incl. pigtail)	
Control and indicator elements ^[7]	Select & function keys: interface selections, mastering (zero), teach, presets, quality slider, frequency selection, factory settings; web interface for setup: application-specific presets, peak selection, video signal, freely selectable averaging possibilities, data reduction, setup management; 2 x color LEDs for power / status	

^[1] Factory setting 4 kHz, median 9, modifying the factory setting requires the IF2001/USB converter (see accessories)

^[2] FSO = Full Scale Output; data related to the digital output and valid for white, diffusely reflecting surfaces (Micro-Epsilon reference ceramic for ILD sensors)

^[3] Typical value with measurements at 4 kHz and median 9

^[4] ± 15 %; light spot diameter determined with point-shaped laser with Gaussian fit (full 1/e² width)

^[5] Illuminant: light bulb

^[6] For EtherCAT, PROFINET and EtherNet/IP, connection via interface module is required (see accessories)

^[7] Access to web interface requires connection to PC via IF2001/USB (see accessories)

Dimensions

optoNCDT 17x0

optoNCDT 1710BL

Window cmos ($\varnothing 35.5$) $\varnothing 30$ free Window laser ($\varnothing 12.5$) $\varnothing 5$ free

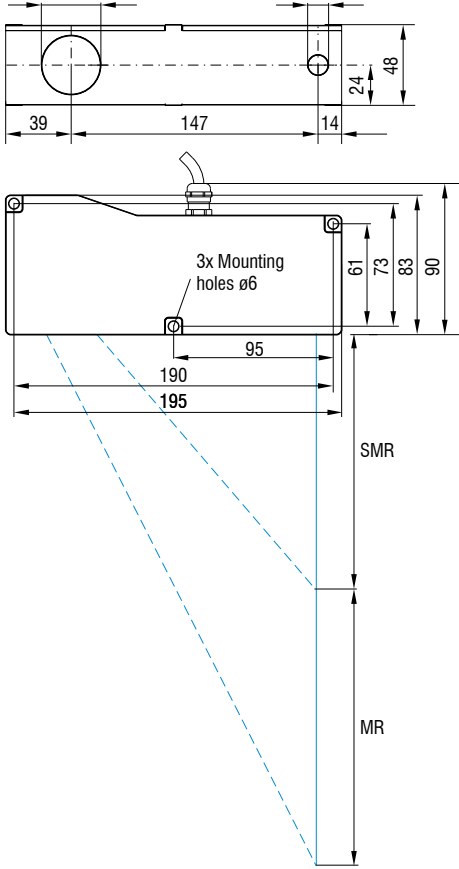

MR	SMR
50	550
1000	1000

Connector (sensor side)

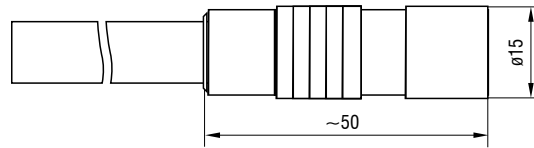

optoNCDT 1750DR

MR	a	b	c	d	e	f	g	h	i	j
2	1	26.5	25	20°	16.7	20.7	82.6	83.7	49.5	45.6
10	5	29	35.5	17.6°	28.3	32.3	91.1	96.2	49.2	45.7
20	10	30.9	63.5	11.5°	58.6	62.6	113.2	128.2	44.3	49.6

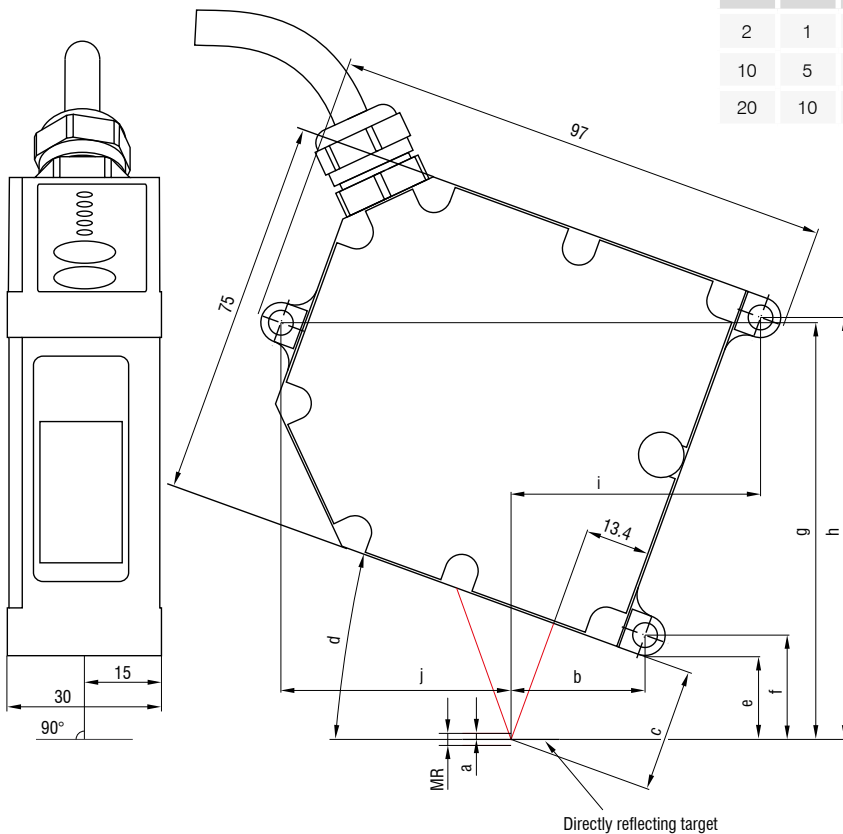

Connector (sensor side)

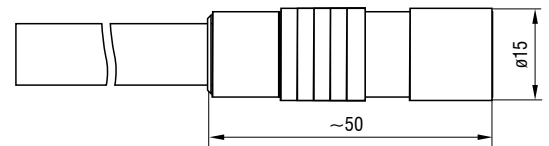

optoNCDT 1750BL / Measuring ranges 20 / 200

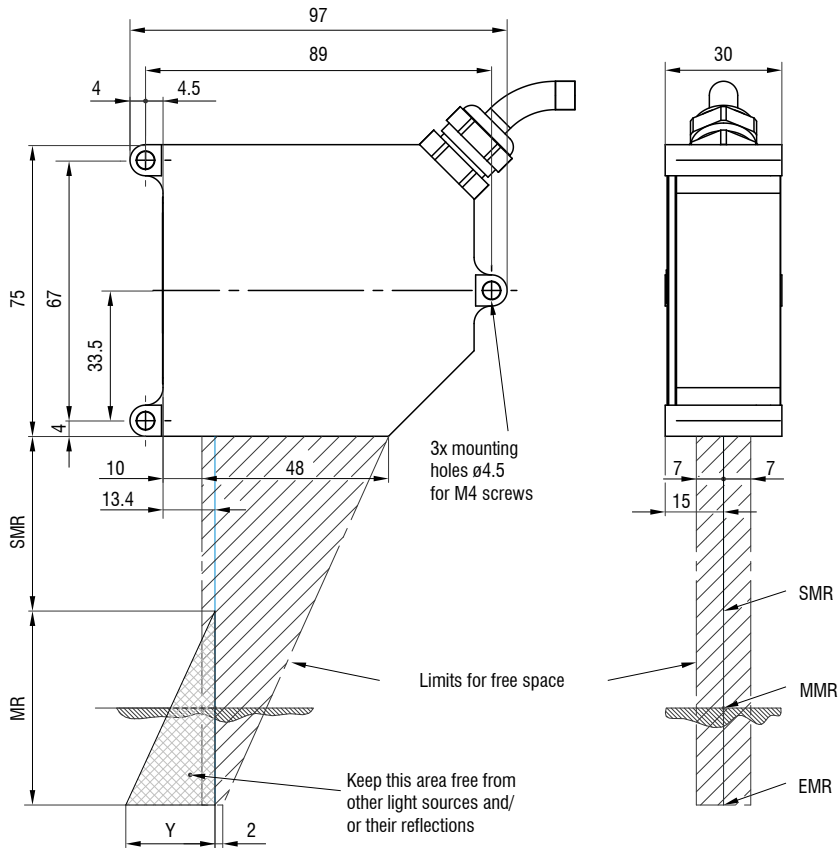

MR	SMR	Y
20	40	12
200	100	70

Connector (sensor side)

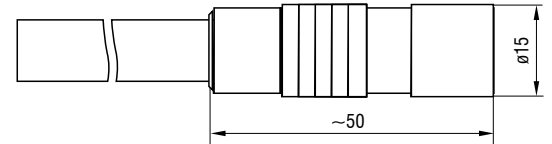

optoNCDT 1750BL / Measuring ranges 500 / 750

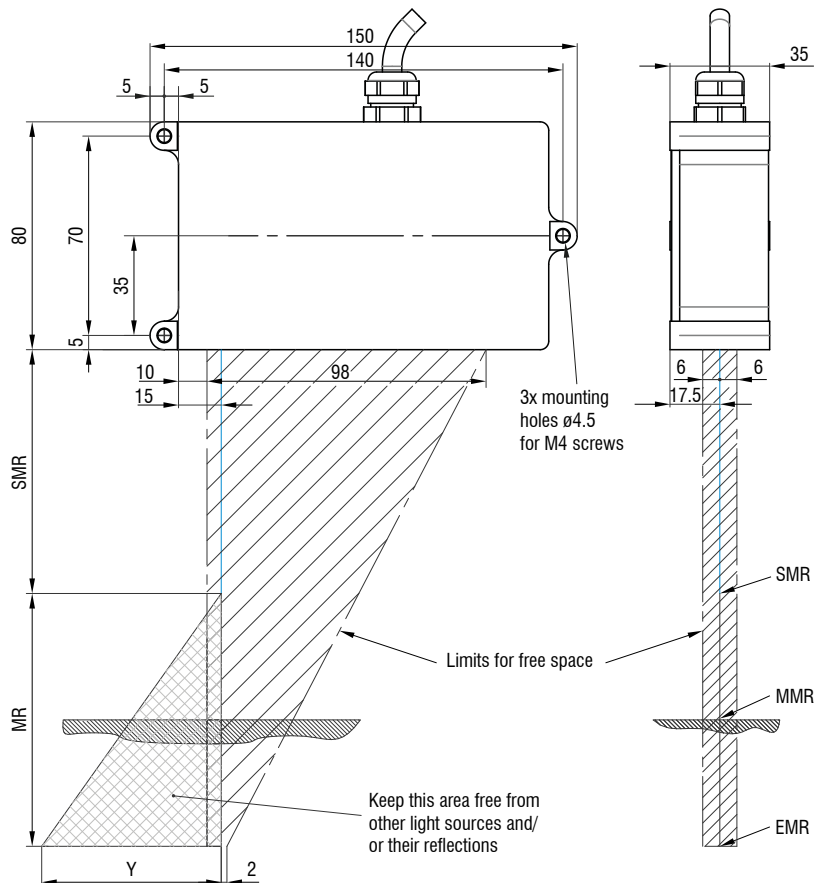

MR	SMR	Y
500	200	180
750	200	270

Connector (sensor side)

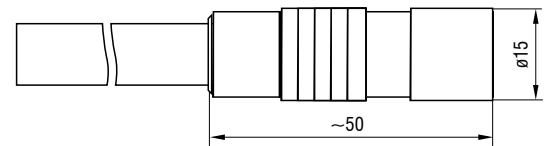

(Dimensions in mm, not to scale)
 MR = measuring range; SMR = start of measuring range,
 MMR = Mid of measuring range, EMR = end of measuring range

Dimensions optoNCDT 17x0

optoNCDT 1710-50 / 1760-1000

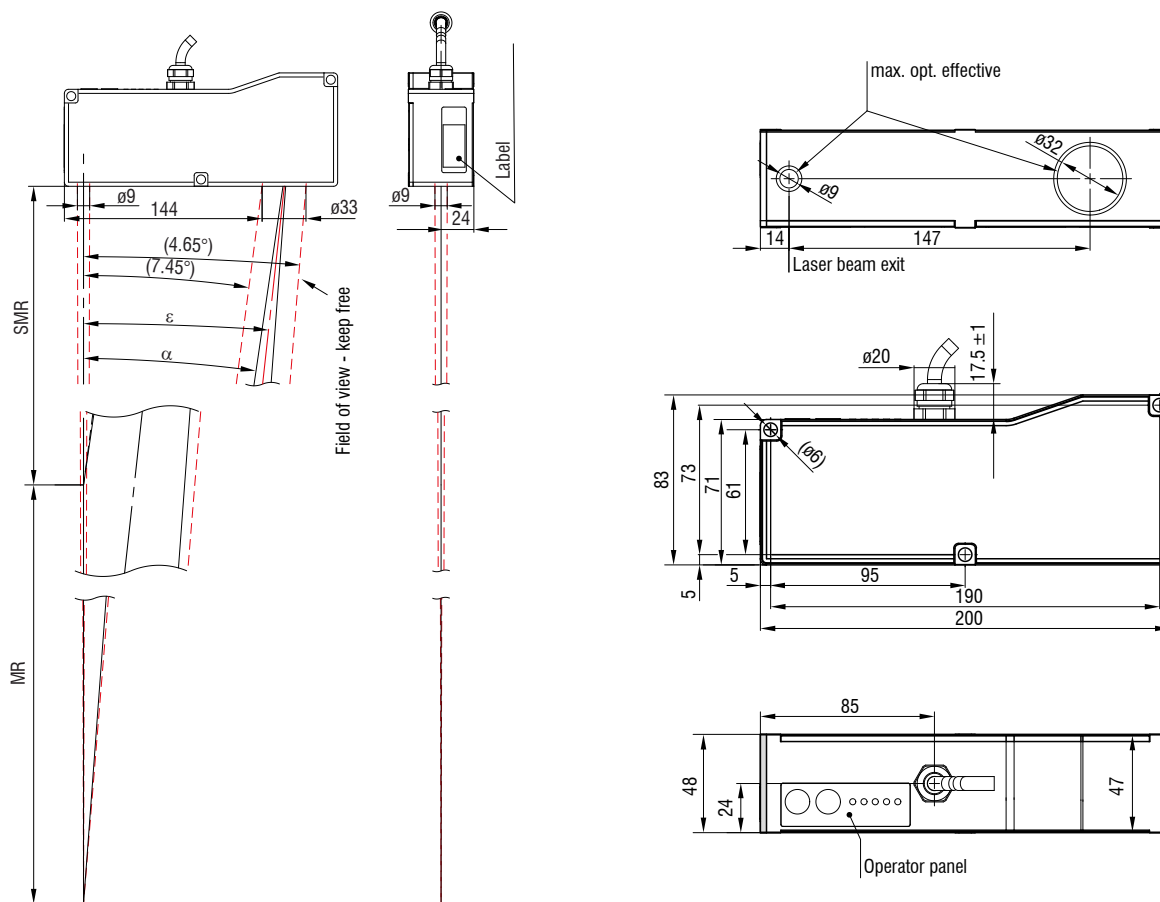

MR	SMR	α	ε
50	550	13.35 °	15.15 °
1000	1000	7.45 °	4.65 °

Connector (sensor side)

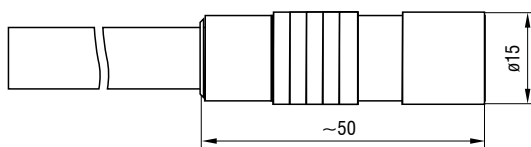

(Dimensions in mm, not to scale)

MR = measuring range; SMR = start of measuring range,

MMR = Mid of measuring range, EMR = end of measuring range







Connection possibilities

optoNCDT 17x0 / 1910

optoNCDT 1700 / 1750 / 1760



Drag-chain suitable extension and adapter cables

Cable diameter: 6.8 ±0.2 mm
 Drag chain: yes
 Robot: no
 Temperature range: -40 ... 90 °C (moving /not moving)
 Bending radius: > 55 mm (fixed installation / dynamic / drag chain)

Sensor	Cables	Type	Connection possibilities and accessories	
ILD1710-50 ILD1710-xxBL ILD1750-xxBL ILD1750-xxDR ILD1760-1000	Extension cable pigtail Length 3 m / 6 m / 9 m / 15 m <i>Art. no.</i> <i>Designation</i> 2901189 PC1700-3 2901357 PC1700-6 2901191 PC1700-10 2901266 PC1700-15	Open ends	Supply voltage connection Power supply unit PS2020 	Interface module of RS422 to USB IF2001/USB IC2001/USB 
	Adapter cable for PC interface card Length 3 m / 6 m <i>Art. no.</i> <i>Designation</i> 2901555 PC1700-3/IF2008 2901556 PC1700-6/IF2008 2901557 PC1700-8/IF2008	Sub-D	Interface module for Industrial Ethernet connection IF2035-PROFINET IF2035-EIP IF2035-EtherCAT (not for ILD1710) 	Interface card for synchronous data acquisition IF2008PCIe / IF2008E 
	Adapter cable for sensor calculation Length 3 m / 6 m / 9 m <i>Art. no.</i> <i>Designation</i> 29011173 PC1750-3/C-Box 29011180 PC1750-6/C-Box 29011181 PC1750-9/C-Box	Sub-D	4-fold USB converter IF2004/USB 	Controller for D/A conversion and evaluation of up to 2 sensor signals Dual Processing Unit 



Robot-suitable extension cables

Cable diameter: max. 9 mm
 Drag chain: no
 Robot: yes
 Temperature range: -40 ... 70 °C (moving / not moving)
 Bending radius: 110 mm (dynamic)

Sensor	Cables	Type	Connection possibilities and accessories	
ILD1710-50 ILD1710-xxBL ILD1750-xxBL ILD1750-xxDR ILD1760-1000	Extension cable pigtail: Length 3 m / 6 m / 9 m / 15 m <i>Art. no.</i> <i>Designation</i> 2901494 PCR1700-5 2901299 PCR1700-10	Open ends	Connection supply voltage PS2020 	Interface module from RS422 to USB IF2001/USB IC2001/USB 
			Interface module for Industrial Ethernet connection IF2035-PROFINET IF2035-EIP IF2035-EtherCAT (not for ILD1710) 	



Extension cables for high temperatures

Cable diameter:	max. 7.5 mm
Drag chain:	no
Robot:	no
Temperature range:	-55 ... 250 °C (moving) -90 ... 250 °C (not moving)
Bending radius:	> 40 mm (fixed installation) > 75 mm (dynamic)

Sensor	Cables	Type	Connection possibilities and accessories									
ILD1710-50 ILD1710-xxBL	Extension cables high temperatures Length 3 m / 6 m / 9 m / 15 m <table border="1"> <thead> <tr> <th>Art. no.</th> <th>Designation</th> </tr> </thead> <tbody> <tr> <td>29011091</td> <td>PC1700-3/OE/HT</td> </tr> <tr> <td>29011092</td> <td>PC1700-6/OE/HT</td> </tr> <tr> <td>29011094</td> <td>PC1700-15/OE/HT</td> </tr> </tbody> </table>	Art. no.	Designation	29011091	PC1700-3/OE/HT	29011092	PC1700-6/OE/HT	29011094	PC1700-15/OE/HT	Open ends	Supply voltage connection Power supply unit PS2020	
Art. no.		Designation										
29011091		PC1700-3/OE/HT										
29011092	PC1700-6/OE/HT											
29011094	PC1700-15/OE/HT											
ILD1750-xxBL ILD1750-xxDR	Interface module of RS422 to USB IF2001/USB											
ILD1760-1000	Interface module for Industrial Ethernet connection IF2035-PROFINET IF2035-EIP IF2035-EtherCAT (not for ILD1710)											

Other cables

Cable diameter:	6.7 mm
Drag chain:	yes
Robot:	no
Temperature range:	-40 ... 80 °C
Bending radius:	> 27 mm (fixed installation) > 51 mm (dynamic)

Input	Cables	Type	Connection possibilities and accessories					
2 x Sub-D (PC1700-x/ IF2008)	Adapter cables for 4-fold sensor connection Length 0.1 m <table border="1"> <thead> <tr> <th>Art. no.</th> <th>Designation</th> </tr> </thead> <tbody> <tr> <td>2901528</td> <td>IF2008-Y-adapter cable</td> </tr> </tbody> </table> 	Art. no.	Designation	2901528	IF2008-Y-adapter cable	Sub-D	Interface card for synchronous data acquisition IF2008PCle / IF2008E	
Art. no.	Designation							
2901528	IF2008-Y-adapter cable							
			4-fold USB converter & parameter setting IF2004/USB					

optoNCDT 1910

see Connection possibilities optoNCDT 1900 on pg. 32.

IF2035: Interface module for Industrial Ethernet connection

- Connection of RS422 or RS485 interfaces to PROFINET / Ethernet/IP / EtherCAT
- Synchronization output for RS422 sensors
- 2 network connections for different network topologies
- Data rate up to 4 MBaud
- 4-fold oversampling (with EtherCAT)
- Ideal for confined spaces due to a compact housing and DIN rail mounting

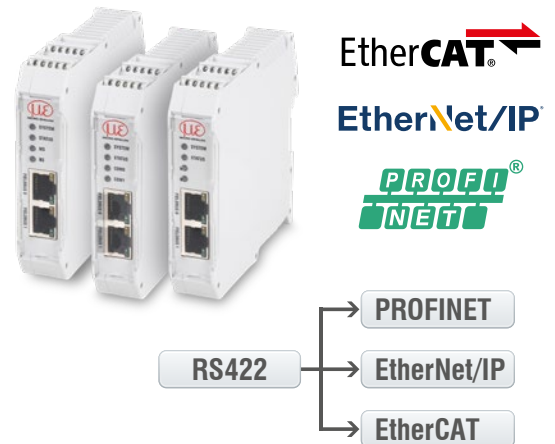

IF2008PCIe/IF2008E: Interface card for synchronous data acquisition

- IF2008PCIe - Basic PCB: 4 digital signals and 2 encoders
- IF2008E - Expansion board: 2x digital signals, 2x analog signals and 8x I/O signals
- Absolutely synchronous data acquisition for multi-channel applications (e.g. for planarity or thickness measurement)

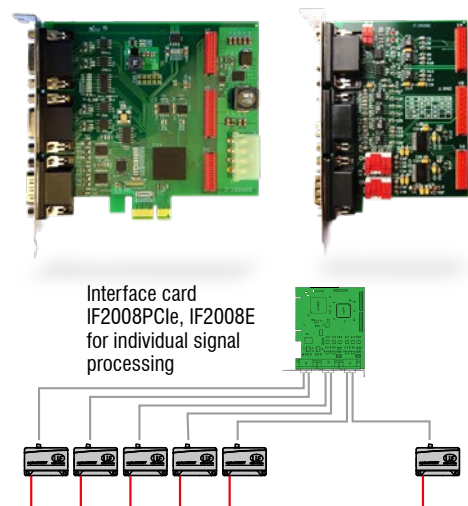

Dual Processing Unit: Controller for D/A conversion and evaluation of up to 2 sensor signals

- Fast D/A conversion (16 bit, with a maximum of 100 kHz) of 2 digital input signals or calculation of 2 digital sensor signals
- Averaging functions and calculation of thickness, step, diameter, ovality and radial run out
- Trigger input
- Multi-function output
- Measurement value output via Ethernet, USB, analog output 4 ... 20 mA/0 ... 5 V / 0 ... 10 V / ± 5 V / ± 10 V (scalable via web interface)
- 2x switching outputs for sensor or Dual Processing Unit status
- Parallel data output via three output interfaces
- Two filter possibilities
- Post-linearization of measured values or calculated values
- Easy parameter setting via web interface (controller and sensors)



IF2008/ETH: Interface module for Ethernet connection of up to 8 sensors

- Integration of eight sensors or encoders with RS422 interface in Ethernet network
- Four programmable switching in-/outputs (TTL and HTL logic)
- Fast data acquisition and output up to 200 kHz
- Simple parameter set up via web interface



IC2001/USB Single-channel converter cable RS422/USB

- Conversion from RS422 to USB
- 5-core interface cable without outer shield
- Easy sensor connection via USB
- Supports baud rates from 9.6 kBaud to 1 MBaud
- Ideal for integration into plant and machinery



IF2001/USB: Interface module from RS422 to USB

- Conversion from RS422 to USB
- Signals and functions such as laser on/off, switch signals and function output
- Supports baud rates from 9.6 kBaud to 12 MBaud
- Robust aluminum housing
- Easy sensor connection via screw terminals (plug and play)
- Parameter setting (converter and sensors) via software



IF2004/USB: 4-fold interface module from RS422 to USB





- Conversion of 4 digital signals (RS422) to USB
- 4x trigger inputs, 1x trigger output
- Synchronous data acquisition
- Parameter setting (converter and sensors) via software



Connection of 4 sensors via IF2008-Y-adapter cable

Protective housings for demanding environments

optoNCDT

SGH & SGHF models				SGHF-HT model
Protective housing Size S		Protective housing Size M		
SGH	SGHF	SGH	SGHF	
				
(140 x 140 x 71 mm)		(180 x 140 x 71 mm)		(260 x 180 x 154 mm)
Water-resistant housing protects the sensor from solvents and detergents.	Ideal with high ambient temperatures. The integrated air cooling of the housing offers optimum protection for the sensor.	Water-resistant housing protects the sensor from solvents and detergents.	Ideal with high ambient temperatures. The integrated air cooling of the housing offers optimum protection for the sensor.	Water-cooled protective housing with window and compressed-air connection for measurement tasks in ambient temperatures up to 200 °C. Maximum temperature of cooling water T(max) = 10 °C Minimum water flow rate Q(min) = 3 liters/min
Size S suitable for ILD1750-20BL ILD1750-200BL ILD2300-2 / -2LL / -2BL ILD2300-5 / -5BL ILD2300-10 / -10LL / -10BL ILD2300-20 / -20LL ILD2300-50 / -50LL ILD2300-100		Size M suitable for ILD1750-500BL ILD1750-750BL ILD2300-200 ILD2300-300 ILD2310-10 ILD2310-20 ILD2310-40		Suitable for ILD1710-50 / -50BL ILD1710-1000 / -1000BL ILD1750-500BL ILD1750-750BL ILD2300-200 ILD2300-300 ILD2310-10 ILD2310-20 ILD2310-40 ILD2310-50BL

Protective housing SGHF ILD1900

Compact protective housing which is simply attached to the sensor. The protective housing has an air purge for cleaning the protective windows. It also cools the sensor.
Suitable for ILD1900-6 / -6LL ILD1900-10 / -10LL ILD1900-25 / -25LL ILD1900-50 / -50LL ILD1900-100 ILD1900-200 ILD1900-500

sensorTOOL

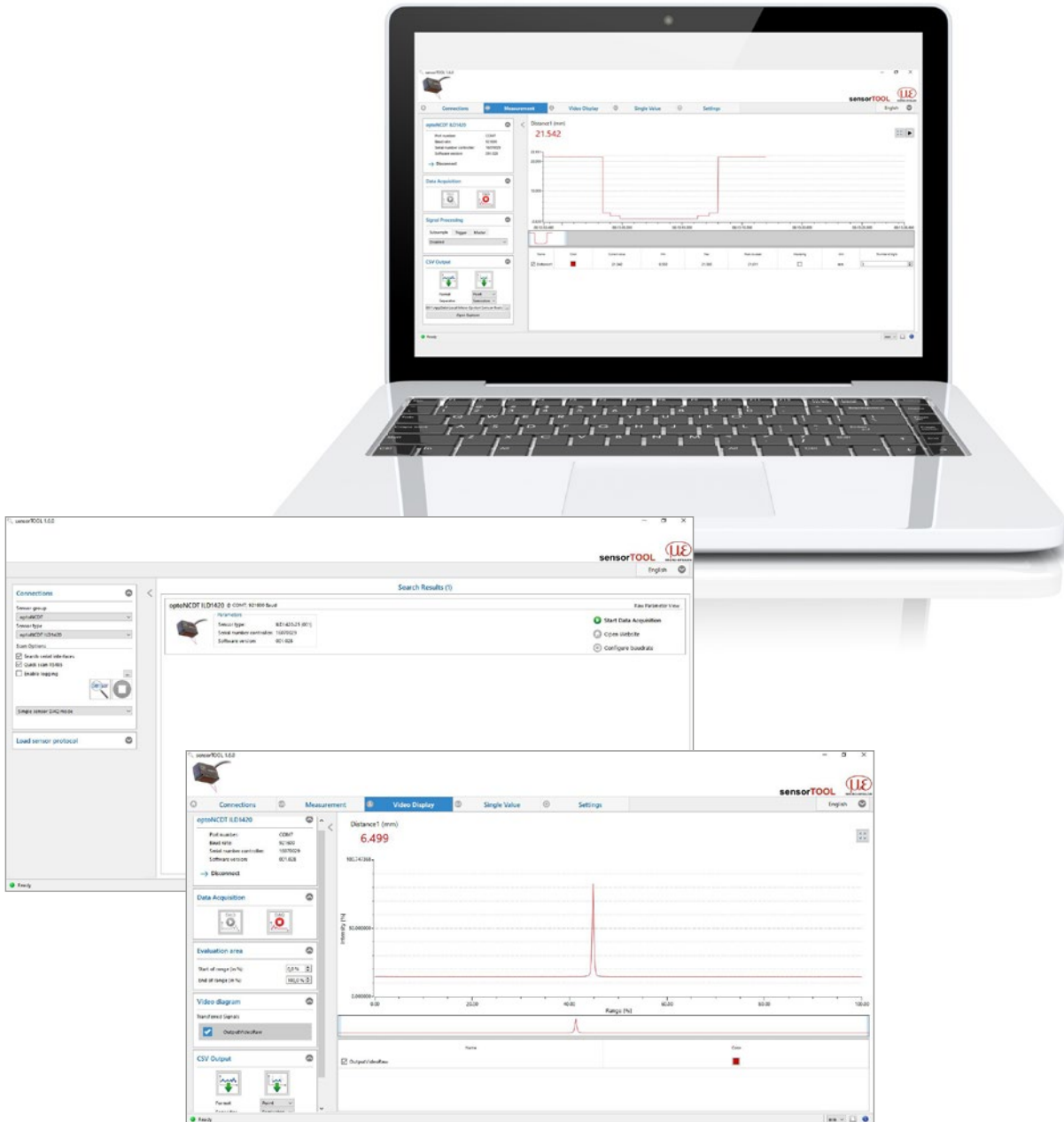
The Micro-Epsilon sensorTOOL is a powerful software that is used to operate one or more optoNCDT sensors. The sensorTOOL can be used to access the sensor connected to the PC, display its complete data stream and save it in a file (in Excel-compatible CSV format). The sensor is configured via its web interface.



Free download

All software tools, drivers and documented driver DLL for easy integration of the sensors into existing or internally-generated software are available free of charge under www.micro-epsilon.de/download

Sensors and Systems from Micro-Epsilon



Sensors and systems for displacement, distance and position



Sensors and measurement devices for non-contact temperature measurement

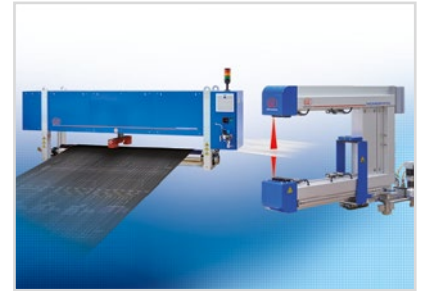

Measuring and inspection systems for metal strips, plastics and rubber



Optical micrometers and fiber optics, measuring and test amplifiers



Color recognition sensors, LED analyzers and inline color spectrometers



3D measurement technology for dimensional testing and surface inspection