

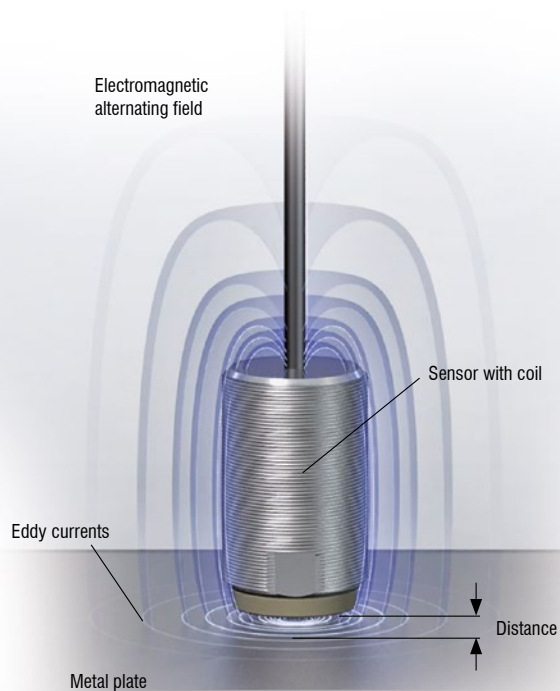

More Precision

eddyNCDT // Inductive sensors based on eddy currents





Measuring principle

Among inductive displacement sensors, the eddy current principle occupies a unique position. Measuring via eddy current is based on the extraction of energy from an oscillating circuit. This energy is needed for the induction of eddy currents in electrically-conductive materials. Here, a coil is supplied with an alternating current, causing a magnetic field to form around the coil. If an electrically conducting object is placed in this magnetic field, eddy currents are induced which form a field according to Faraday's induction law. This field acts against the field of the coil, which also causes a change in the impedance of the coil. The impedance can be calculated by the controller by looking at the change in the amplitude and phase position of the sensor coil.







High precision

For many years, Micro-Epsilon has been a pioneer in displacement measurement using high precision eddy current technology. The eddyNCDT displacement sensors are designed for non-contact measurement of displacement, distance, position, oscillation and vibrations. Considered as extremely precise and robust, they are preferably used in industrial environments.

Advantages

- Wear-free and non-contact measurement
- Highest precision and resolution
- High temperature stability
- Ferromagnetic and non-ferromagnetic materials
- For demanding, industrial environments: dirt, pressure, temperature
- Fast measurements up to 100 kHz

Overview

	Eddy current sensor with integrated controller eddyNCDT 3001 <ul style="list-style-type: none">▪ Measuring ranges 2 - 8 mm▪ Resolution $\geq 3 \mu\text{m}$▪ Frequency response 5 kHz	page 6 - 9
	Compact eddy current measuring system eddyNCDT 3005 <ul style="list-style-type: none">▪ Measuring ranges 1 - 6 mm▪ Resolution $\geq 0.5 \mu\text{m}$▪ Frequency response 5 kHz	page 10 - 11
	High-performance inductive measuring system eddyNCDT 3060 <ul style="list-style-type: none">▪ Measuring ranges 1 - 8 mm▪ Resolution $\geq 0.02 \mu\text{m}$▪ Frequency response up to 20 kHz	page 12 - 17
	High-performance inductive measuring system eddyNCDT 3070 <ul style="list-style-type: none">▪ Measuring ranges $< 1 \text{ mm}$▪ Resolution $\geq 0.02 \mu\text{m}$▪ Frequency response up to 20 kHz	page 18 - 21
	High precision eddy current displacement measurement eddyNCDT 3300 <ul style="list-style-type: none">▪ Measuring ranges 0.4 - 80 mm▪ Resolution $\geq 0.02 \mu\text{m}$▪ Frequency response up to 100 kHz	page 22 - 31
	Turbocharger speed measurement turboSPEED DZ140 <ul style="list-style-type: none">▪ Measuring ranges 0.5 - 1 mm▪ Speed range from 200 to 400,000 rpm▪ Sensor operating temperature up to 285 °C	page 32 - 37
	Spindle growth measuring system eddyNCDT SGS4701 <ul style="list-style-type: none">▪ Measuring ranges 250 - 500 μm▪ Resolution $\geq 0.5 \mu\text{m}$▪ Frequency response 2 kHz	page 38 - 39
	Application examples	pages 40 - 41
	Accessories	page 42
	Technical information	pages 43 - 47

Industrial displacement measurement with highest precision

eddyNCDT

Robust sensors with maximum precision

eddyNCDT eddy current sensors from Micro-Epsilon are often used in applications requiring maximum precision in harsh ambient conditions. Immunity to dirt, pressure and extreme temperature are their distinctive features.

Advantages over conventional inductive sensors

- High frequency response for dynamic measurements
- High resolution in the submicron range
- High linearity and temperature stability
- Measurement on ferromagnetic and non-ferromagnetic targets



Measuring ranges 0.5 mm to 80 mm



Comprehensive product range

- More than 400 sensor models
- Miniature sensors smaller than 2 mm
- Customer-specific modifications and OEM

Oil **Dust** **Dirt** **Water** **Vapors**

Resistant to media in the measuring gap

- Protection class IP67
- Pressure-resistant models up to 2000 bar

St 37 **Al** **Factory-calibrated for steel or aluminum - other alloys also possible**

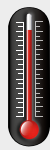

Best temperature stability in the world

- Active temperature compensation of sensor and controller
- Temperature range -40 °C to 200 °C and higher

Specific sensors for OEM applications

Application examples are often found where the standard versions of the sensors and the controllers are performing at their limits. For these special tasks, we modify your measuring system according to your individual requirements. Changes requested include, for example, modified designs, target calibration, mounting options, individual cable lengths, modified measuring ranges or sensors with integrated controller.

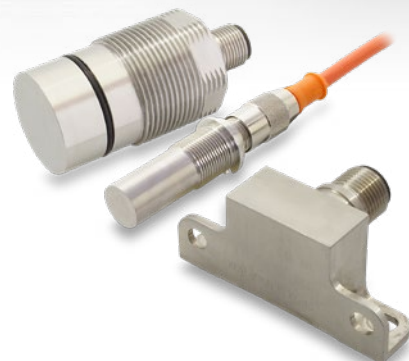

Standard installation situation

Each eddyNCDT sensor is factory-calibrated under standardized installation conditions. These installation conditions involve mounting, positioning of the nut and surrounding materials. Deviations in installation situations may affect the linearity and accuracy. Field linearization or special tuning in the factory may counteract this effect.

Standard target materials

eddyNCDT sensors are factory-calibrated for the following materials:

Ferromagnetic target: Steel (St37) DIN1.0037

Non-ferromagnetic target: Aluminum AlMg3 DIN3.3535

Customer-specific adjustment for other materials is also possible.

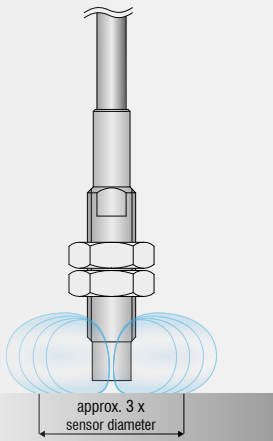

✓ Standard installation with unshielded sensors
no linearization required



F Installation of unshielded sensors with a recess
requires field linearization (DT306x / DT3300)



M Flush installation with unshielded sensors
requires factory calibration

Unshielded sensors (e.g. EU1)

Unshielded sensors are more compact than shielded sensors with the same measuring range. With unshielded sensors, the field lines emerge also at the side of the sensor which extends its measuring range. Nevertheless, the sensor design remains compact. The measurement spot is approximately three times the sensor diameter.

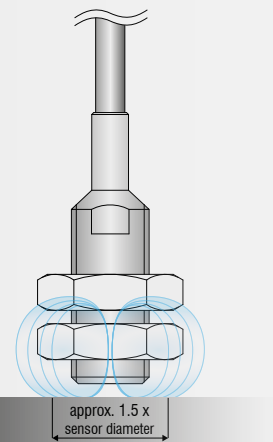

✓ Standard installation with shielded sensors
no linearization required









F Flush installation with shielded sensors
requires field linearization (DT306x / DT3300)

Shielded sensors (e.g. ES1)

Shielded sensors are larger than unshielded sensors with the same measuring range. A separate sheathing achieves a narrower distribution of the field lines, so they are insensitive to radially adjacent metals. The measurement spot is approximately one and a half times the sensor diameter.

Compact eddy current sensors with integrated controller

eddyNCDT 3001

-  Compact M12 sensor design with integrated controller
-  Frequency response 5 kHz (-3dB)
-  Measuring rate 75 kSa/s
-  Sensors for ferromagnetic and non-ferromagnetic targets
-  Temperature compensation up to 70 °C
-  Easy to use (plug & play)
-  Robust design to IP67



Robust M12 miniature eddy current sensor

The two eddyNCDT 3001 U2 and U4 models are powerful eddy current sensors whose compact dimensions have to date only been reserved for inductive sensors and proximity sensors. These compact sensors come with integrated controller including temperature compensation while offering an excellent price/performance ratio, as well as easy operation. Therefore, the sensors are ideally suited to OEM integration and machine building applications.

The temperature-compensated design provides high stability even in fluctuating ambient temperatures. The sensors are factory-calibrated for ferromagnetic and non-ferromagnetic materials, which eliminates the need for on-site linearization of the sensor. Its robust design combined with the eddy current measuring principle enables measurements in harsh industrial environments (oil, pressure, dirt). In addition, the eddyNCDT 3001 is suitable for offshore/marine applications (salt water).

Model	DT3001-U2-A-SA	DT3001-U2-M-SA	DT3001-U4-A-SA	DT3001-U4-M-SA	DT3001-U4-A-Cx	DT3001-U4-M-Cx
Measuring range	2 mm		4 mm			
Start of measuring range			0.4 mm			
Resolution ¹⁾			4 μ m			
Frequency response (-3dB)			5 kHz			
Measuring rate	Analog output		75 kSa/s (16 bit)			
Linearity			< $\pm 28 \mu$ m			
Temperature stability ²⁾	< 0.6 μ m / K		< 1.2 μ m / K			
Temperature compensation			0 ... +70 °C			
Sensor type			unshielded			
Min. target size (flat)			\varnothing 48 mm			
Target material ³⁾	Aluminum	Steel	Aluminum	Steel	Aluminum	Steel
Supply voltage			12 ... 32 VDC			
Power consumption			0.5 W			
Analog output			0.5 ... 9.5V		0.5 ... 4.5V	
Connection	Supply/signal: 5-pole M12 connector (cable see accessories)				integrated cable, 5-pin, lengths: 3/6/9 m	
Temperature range	Storage			-20 ... +80 °C		
	Operation			0 ... +70 °C		
Shock (DIN EN 60068-2-27)			15 g / 6 ms in 3 axes, 2 directions and 1000 shocks each			
Vibration (DIN EN 60068-2-6)			5 g / 10 ... 500 Hz in 3 axes, 2 directions and 10 cycles each			
Protection class (DIN EN 60529)			IP67 (plugged)		IP67	
Weight			25 g		60 g (3 m) 100 g (6 m) 140 g (9 m)	

¹⁾ RMS noise relates to mid of measuring range at a frequency response of 5 kHz

²⁾ Relates to the mid of the measuring range, in the compensated temperature range

³⁾ Steel: St37 steel DIN1.0037 / aluminum: AlMg3

DT3001-U2-SA DT3001-U4-SA

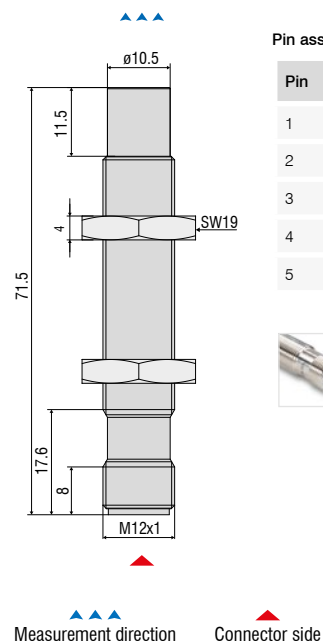

Pin assignment for power supply and signal

Pin	Assignment	Color (cable: PCx/5-M12)
1	Supply +24 V	Brown
2	Displacement signal	White
3	GND	Blue
4	internal	Black
5	internal	Gray

5-pin housing connector M12x1
View on pin side

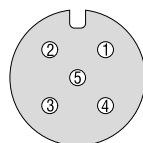

DT3001-U4-Cx

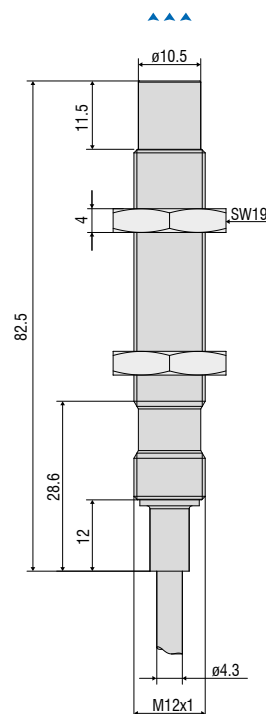







Pin assignment of integrated supply and signal cable

Assignment	Cable color
Supply +24 V	Brown
Displacement signal	Green
GND	White
internal	Yellow
internal	Gray

Dimensions in mm, not to scale.

Compact eddy current sensors with integrated controller

eddyNCDT 3001

-  Compact M18 sensor design with integrated controller
-  Frequency response 5 kHz (-3dB)
-  Measuring rate 75 kSa/s
-  Sensors for ferromagnetic and non-ferromagnetic targets
-  Temperature compensation up to 70 °C
-  Easy to use (plug & play)
-  Robust design to IP67



Robust miniature sensors in M18 housing

The U6 and U8 models of the eddyNCDT 3001 series are powerful eddy current sensors with integrated controller in an M18 design. Calibrated for ferromagnetic or non-ferromagnetic materials, these compact sensors offer measuring ranges of 6 mm or 8 mm.

As these sensors are temperature-compensated, they provide high signal stability even in fluctuating ambient temperatures. Due to their robust design, these sensors are used for measurement tasks in harsh, industrial environments.

Model	DT3001-U6-A-SA	DT3001-U6-M-SA	DT3001-U8-A-SA	DT3001-U8-M-SA
Measuring range	6 mm		8 mm	
Start of measuring range	0.6 mm		0.8 mm	
Resolution ¹⁾	3 μ m		4 μ m	
Frequency response (-3dB)	5 kHz			
Measuring rate	Analog output	75 kSa/s (16 bit)		
Linearity	< $\pm 15 \mu$ m		< $\pm 20 \mu$ m	
Temperature stability ²⁾	< 1.5 μ m / K		< 2 μ m / K	
Temperature compensation	0 ... +70 °C			
Sensor type	unshielded			
Min. target size (flat)	\varnothing 72 mm			
Target material ³⁾	Aluminum	Steel	Aluminum	Steel
Supply voltage	12 ... 32 VDC			
Power consumption	0.6 W			
Analog output	0.5 ... 9.5 V			
Connection	Supply/signal: 5-pole M12 connector (cable see accessories)			
Temperature range	Storage	-20 ... +70 °C		
	Operation	-20 ... +70 °C		
Shock (DIN EN 60068-2-27)	15 g / 6 ms in 3 axes, 2 directions and 1000 shocks each			
Vibration (DIN EN 60068-2-6)	5 g / 10 ... 500 Hz in 3 axes, 2 directions and 10 cycles each			
Protection class (DIN EN 60529)	IP67 (plugged)			
Weight	35 g (without nuts)			

¹⁾ RMS noise relates to mid of measuring range at a frequency response of 5 kHz
²⁾ Relates to the mid of the measuring range, in the compensated temperature range
³⁾ Steel: S137 steel DIN 1.0037 / aluminum: AlMg3

DT3001-U6-SA
DT3001-U8-SA

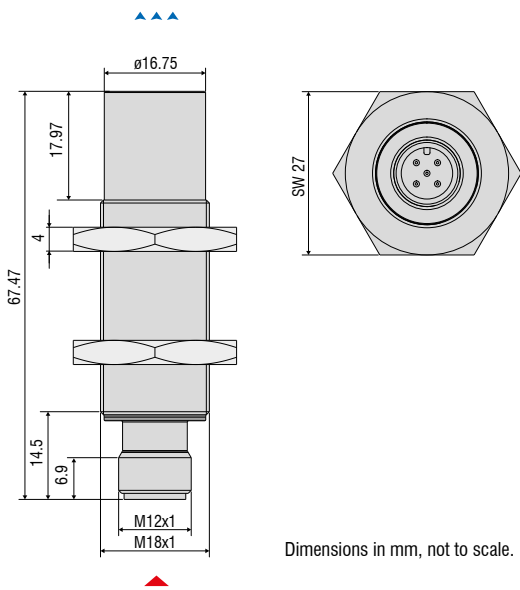

Pin assignment for power supply and signal



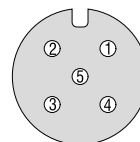
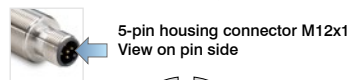



Pin	Assignment	Color (cable: PCx/5-M12)
1	Supply +24 V	Brown
2	Analog output	White
3	GND	Blue
4	internal	Black
5	internal	Gray



Measurement direction
Connector side

Compact eddy current measuring system

eddyNCDT 3005

-  Compact and robust design
-  Temperature compensation up to 180°C
-  High measurement accuracy
-  Frequency response 5 kHz (-3dB)
-  Measuring rate 75 kSa/s
-  Sensors for ferromagnetic and non-ferromagnetic targets
-  Robust design to IP67

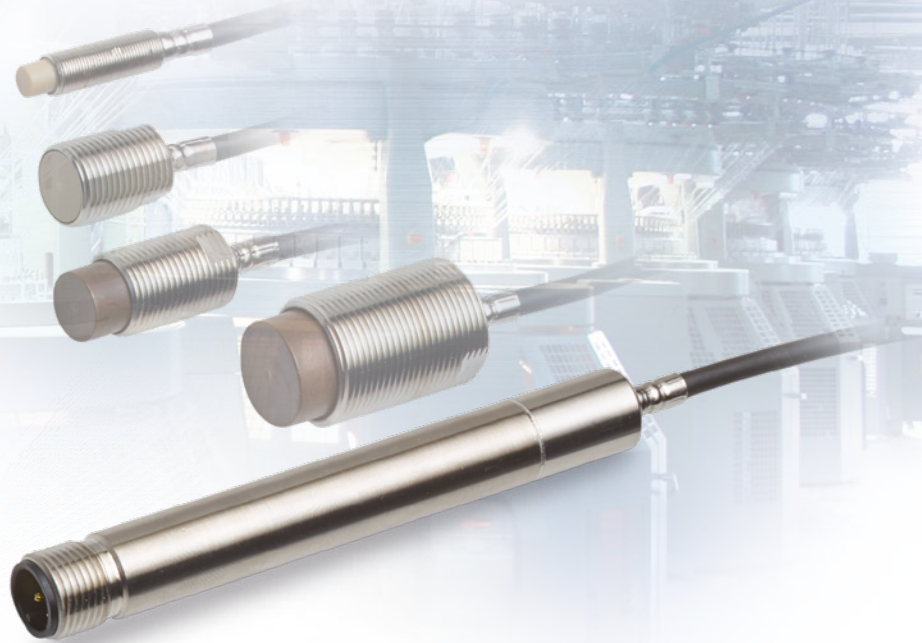

Robust eddy current measuring system

The eddyNCDT 3005 is a powerful eddy current measuring system for fast, high precision displacement measurements. The system comprises a compact controller, a sensor and an integrated cable and is factory-calibrated for ferromagnetic or non-ferromagnetic materials.

As sensor and controller are temperature-compensated, high measurement accuracies can be achieved even in fluctuating temperatures. The sensors are designed for ambient temperatures up to max. +125 °C but can optionally be custom engineered for temperatures from -20 °C to 180 °C. The measuring system is pressure-resistant up to 10 bar and so is ideally suited to machine integration.

Integration into plant and machinery

The eddyNCDT 3005 provides ease of use and high measurement accuracy, offering an outstanding price/performance ratio. Therefore, the sensor is ideal for OEM integration and serial applications in machine building, particularly where pressure, dirt, oil and high temperatures are present. When large quantities are required, customer-specific designs can be tailored to suit individual requirements.



Its compact M12 design allows for the controller to be easily installed in restricted and difficult-to-access places.

Pin assignment for power supply and signal

Pin	Assignment	Color (cable: PCx/5-M12)
1	Supply +24 V	Brown
2	Displacement signal	White
3	GND	Blue
4	RS485 A+	Black
5	RS485 B-	Gray

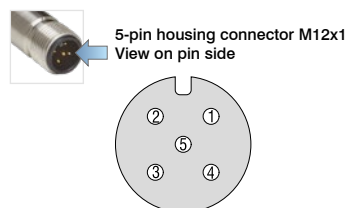





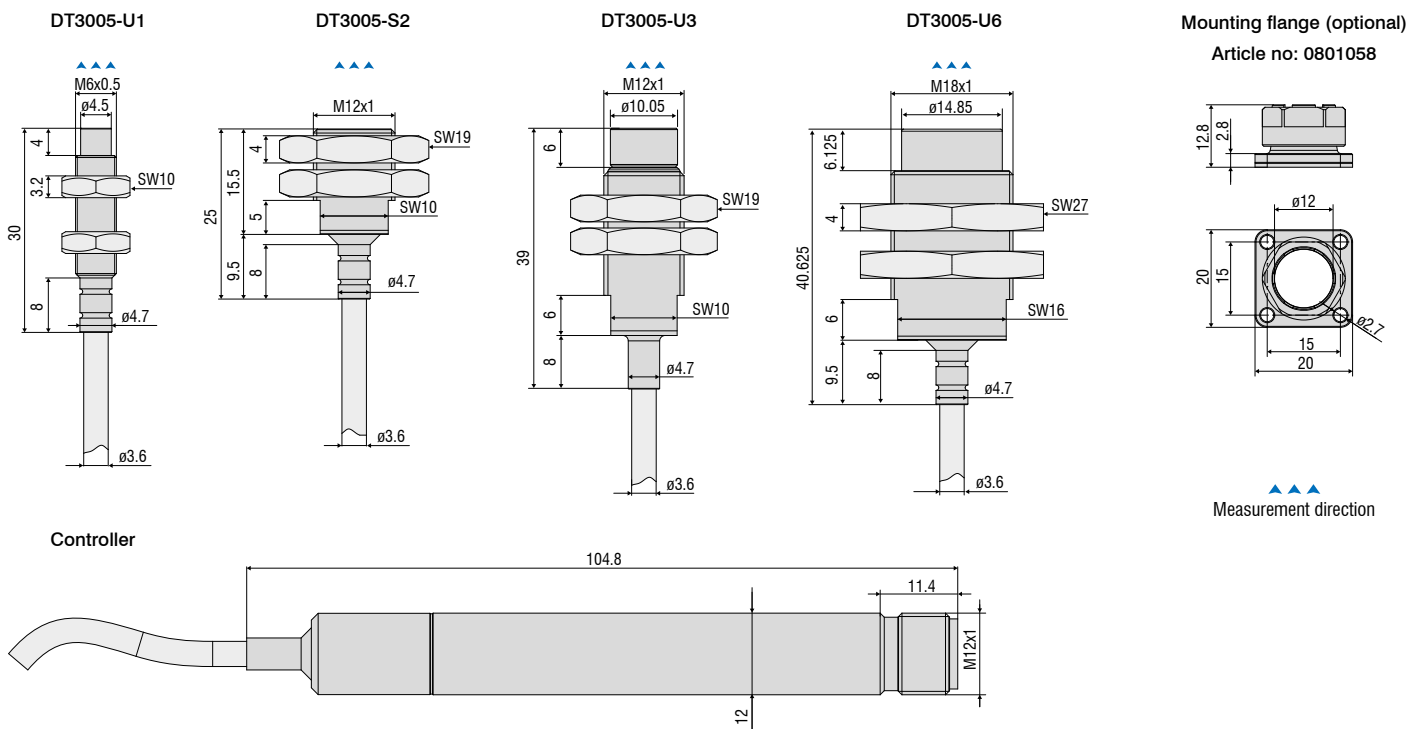



Model	DT3005-U1-A-C1	DT3005-U1-M-C1	DT3005-S2-A-C1	DT3005-S2-M-C1	DT3005-U3-A-C1	DT3005-U3-M-C1	DT3005-U6-A-C1	DT3005-U6-M-C1
Measuring range	1 mm		2 mm		3 mm		6 mm	
Start of measuring range	0.1 mm		0.2 mm		0.3 mm		0.6 mm	
Resolution ¹⁾	0.5 μm		1 μm		1.5 μm		3 μm	
Frequency response (-3dB)	5 kHz							
Measuring rate	Analog output		75 kSa/s (16 bit)					
	Digital interface		1 kSa/s (16 bit)					
Linearity	< ±2.5 μm		< ±5 μm		< ±7.5 μm		< ±15 μm	
Repeatability	< 0.5 μm		< 1 μm		< 1.5 μm		< 3 μm	
Temperature stability ²⁾	Sensor		< 0.25 μm / K		< 0.5 μm / K		< 0.75 μm / K	
	Controller		< 0.25 μm / K		< 0.5 μm / K		< 0.75 μm / K	
Temperature compensation	Sensor		+10 ... +125 °C (optional -20 ... +180 °C)					
	Controller		+10 ... +60 °C (optional -20 ... +70 °C)					
Sensor type	unshielded		shielded		unshielded		unshielded	
Min. target size (flat)	ø 24 mm		ø 24 mm		ø 48 mm		ø 72 mm	
Target material ³⁾	Aluminum	Steel	Aluminum	Steel	Aluminum	Steel	Aluminum	Steel
Supply voltage	12 ... 32 VDC							
Power consumption	0.6 W							
Analog output	0.5 ... 9.5V							
Connection	Sensor: integrated cable, length 1 m, min. bending radius 20 mm Supply/signal: 5-pole M12 connector (cable see accessories)							
Temperature range	Storage		-20 ... +80 °C					
	Operation		Sensor: -20 ... +125 °C (optional -20 ... +180 °C), Controller: -20 ... +70 °C					
Pressure resistance	10 bar (sensor, cable and controller)							
Shock (DIN EN 60068-2-27)	15 g / 6 ms in 3 axes, 2 directions and 1000 shocks each							
Vibration (DIN EN 60068-2-6)	5 g / 10 ... 500 Hz in 3 axes, 2 directions and 10 cycles each							
Protection class (DIN EN 60529)	IP67							
Weight ⁴⁾	70 g		75 g		77 g		95 g	

¹⁾ RMS noise relates to mid of measuring range at a frequency response of 5 kHz
²⁾ Relates to the mid of the measuring range, in the compensated temperature range
³⁾ Steel: St37 steel DIN1.0037 / aluminum: AlMg3
⁴⁾ Total weight for controller, cable and sensor



High-performance inductive measuring system

eddyNCDT 3060

-  Wide range of applications with more than 400 sensor models
-  High temperature stability
-  High resolution & linearity
-  Frequency response 20 kHz (-3dB)
-  Measuring rate 200 kSa/s
-  Sensors for ferromagnetic and non-ferromagnetic targets
-  Analog output (U/I)
Digital output
-  Intuitive configuration via web interface



High performance for the industry

The eddyNCDT 3060 is a powerful, inductive sensor system based on eddy currents for fast, high precision displacement measurements. The system comprises a compact controller, a sensor and an integrated cable and is factory-calibrated either for ferromagnetic or non-ferromagnetic materials.

Integration into plant and machinery

As sensor and controller are temperature-compensated, a high measurement accuracy can be achieved even in fluctuating temperatures. The sensors are designed for ambient temperatures up to a maximum of +200 °C and an ambient pressure up to 20 bar. The compact controller design as well as the sensor robustness make the measuring system ideal for integration into plant and machinery.

New benchmark in controller technology

The industrial-grade M12 Ethernet interface offers a modern fieldbus connection. Configurable analog outputs enable to output the measured values as voltage or current. For operating several systems, a new frequency separation is provided, which enables to operate several sensors next to one another without requiring any synchronization.

Features	Controller type	
	DT3060	DT3061
Active temperature compensation for sensor and controller	✓	✓
Frequency separation (LF & HF)	✓	✓
Ethernet interface	✓	✓
Intuitive web interface	✓	✓
Multipoint calibration regardless of the distance (up to 3-point calibration)	✓	✓
Scalable measuring range via analog output (teach function)	✓	✓
Scalable analog output	✓	✓
Switching and temperature outputs	-	✓
5-point calibration	-	✓
Storage of multiple characteristic curves	-	✓



When connecting a PC via the Ethernet interface, a modern web interface can be accessed without any further installation and enables the parameterization of sensor and controller. The DT3061 controller provides enhanced features such as 5-point calibration, setting of switching and temperature outputs, as well as storage of multiple characteristic curves.

Model	DT3060	DT3061
Resolution ¹⁾	static (20 Hz)	0.002 % FSO
	dynamic (20 kHz)	0.01 % FSO
Frequency response (-3dB)	selectable (20 kHz, 5 kHz, 20 Hz)	
Measuring rate	Analog output	200 kSa/s (16 bit)
	Digital interface	50 kSa/s (16 bit)
Linearity ²⁾	< ±0.2 % FSO	< ±0.1 % FSO
Temperature stability ³⁾	< 0.015 % FSO / K	
Temperature compensation	+10 ... +50 °C	
Target material ⁴⁾	Steel, aluminum	
No. of characteristic curves	1	max. 4
Supply voltage	12 ... 32 VDC	
Power consumption	typ. 2.5 W (max. 2.8 W)	
Digital interface	Ethernet	Ethernet / selectable: switching output (TTL), temperature output (0...5 V)
Analog output	0 ... 10 V; 4 ... 20 mA (short circuit proof)	
Connection	Sensor: pluggable cable via triaxial socket; supply/signal: 8-pole M12 connector; Ethernet: 5-pole M12 connector (cable see accessories)	
Mounting	through bores	
Temperature range	Storage	-10 ... +70 °C
	Operation	0 ... +50 °C
Shock (DIN EN 60068-2-27)	15 g / 6 ms in 3 axes, 2 directions and 1000 shocks each	
Vibration (DIN EN 60068-2-6)	5 g / 10 ... 500 Hz in 3 axes, 2 directions and 10 cycles each	
Protection class (DIN EN 60529)	IP67 (plugged)	
Material	die-cast aluminum	
Weight	approx. 230 g	

FSO = Full Scale Output

¹⁾ RMS noise relates to mid of measuring range

²⁾ Value with 3-/5-point linearization

³⁾ Relates to the mid of the measuring range, in the compensated temperature range

⁴⁾ Steel: St37 steel DIN1.0037 / aluminum: AlMg3

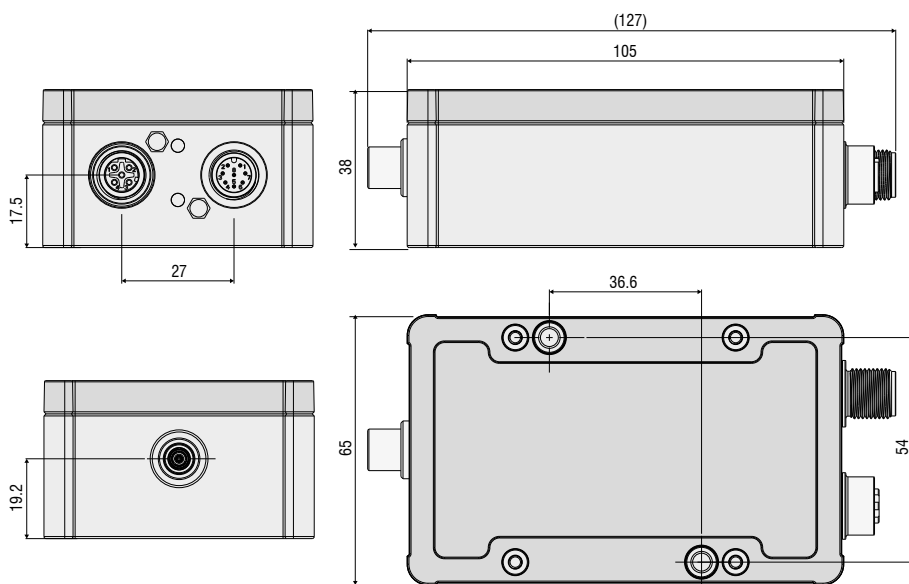

Pin assignment IN/OUT/24V IN

Pin	Assignment	Color (cable: PCx/8-M12)
1	Analog output U _{Displacement}	White
2	Supply +24 V	Brown
3	Limit value 1 / U _{Temp Sensor}	Green
4	Limit value 2 / U _{Temp Controller}	Yellow
5	GND Temperature, Limit value	Gray
6	GND analog output	Pink
7	GND supply	Blue
8	Analog output I _{Displacement}	Red



8-pole M12x1 housing connector
View on pin side

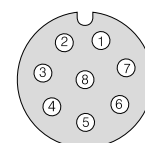

Dimensions in mm, not to scale.

Sensors

eddyNCDT 3060

▲▲▲
Measurement direction

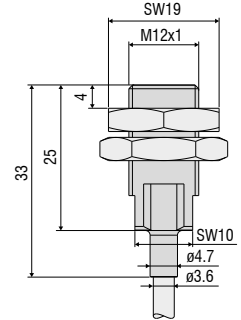
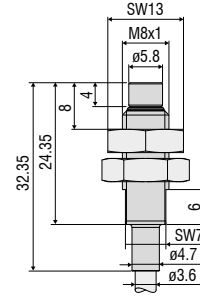
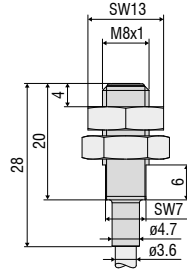
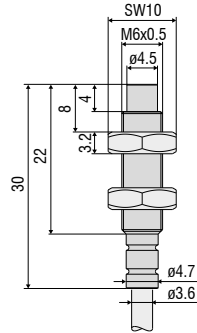

Model	ES-U1	ES-S1	ES-U2	ES-S2
Measuring range	1 mm	1 mm	2 mm	2 mm
Start of measuring range	0.1 mm	0.1 mm	0.2 mm	0.2 mm
Resolution ^{1) 2) 3)}	0.02 μm	0.02 μm	0.04 μm	0.04 μm
Linearity ^{1) 4)}	< ±1 μm	< ±1 μm	< ±2 μm	< ±2 μm
Temperature stability ^{1) 2)}	< 0.15 μm / K	< 0.15 μm / K	< 0.3 μm / K	< 0.3 μm / K
Temperature compensation	+10 ... +180 °C	+10 ... +180 °C	+10 ... +180 °C	+10 ... +180 °C
Sensor type	unshielded	shielded	unshielded	shielded
Min. target size (flat)	Ø 18 mm	Ø 12 mm	Ø 24 mm	Ø 18 mm
Connection	integrated cable, axial, standard length 3 m; 1 m, 6 m, 9 m optional ⁵⁾			
Mounting	Cable gland (M6)	Cable gland (M8)	Cable gland (M8)	Cable gland (M12)
Temperature range	Storage	-20 ... +180 °C	-20 ... +200 °C	-20 ... +200 °C
	Operation	-20 ... +180 °C	-20 ... +200 °C	-20 ... +200 °C
Pressure resistance	20 bar front and rear			
Shock (DIN EN 60068-2-27)	15 g / 6 ms in 3 axes, 2 directions and 1000 shocks each			
Vibration (DIN EN 60068-2-6)	15 g / 49.85 ... 2000 Hz in 3 axes ±3 mm / 10 ... 49.85 Hz in 3 axes			
Protection class (DIN-EN 60529)	IP68 (plugged)			
Material	stainless steel and plastic			
Weight ⁶⁾	approx. 2.4 g	approx. 2.4 g	approx. 4.7 g	approx. 11 g

¹⁾ Valid for operation with DT306x controller, referred to nominal measuring range

²⁾ Relates to the mid of the measuring range, in the compensated temperature range

³⁾ RMS value of the signal noise, static (20 Hz)

⁴⁾ Only with DT3061 controller and 5-point linearization

⁵⁾ Length tolerance cable: nominal value - 0 % / + 30 %

⁶⁾ Weight only sensor without nuts without cable

Additional design: ES-U1-T

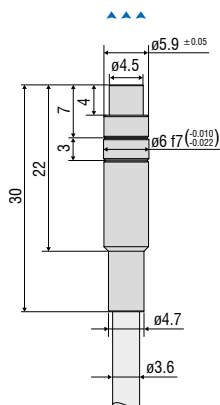

ES-Ux-T design:

Sensors without thread

The ES-Ux-T design are sensors without thread.

These offer additional advantages for installation and temperature stability.

- Thanks to clamp mounting, the cable is not subjected to torsional stress, which prevents damage.
- The sensor has a defined clamping point, which minimizes thermal expansion in the measuring direction and achieves high temperature stability.

▲▲▲▲
Measurement direction

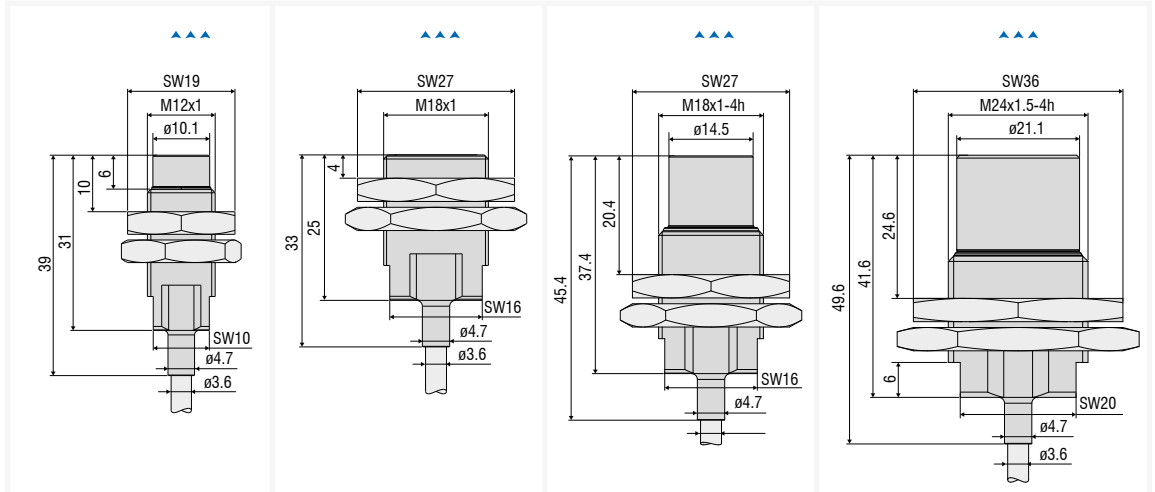

Modell	ES-U3	ES-S4	ES-U6	ES-U8
Measuring range	3 mm	4 mm	6 mm	8 mm
Start of measuring range	0.3 mm	0.4 mm	0.6 mm	0.8 mm
Resolution ^{1) 2) 3)}	0.06 µm	0.08 µm	0.12 µm	0.16 µm
Linearity ^{1) 4)}	< ±3 µm	< ±4 µm	< ±6 µm	< ±8 µm
Temperature stability ^{1) 2)}	< 0.45 µm / K	< 0.6 µm / K	< 0.9 µm / K	< 1.2 µm / K
Temperature compensation	+10 ... +180 °C	+10 ... +180 °C	+10 ... +180 °C	+10 ... +180 °C
Sensor type	unshielded	shielded	unshielded	unshielded
Min. target size (flat)	Ø 36 mm	Ø 27 mm	Ø 54 mm	Ø 72 mm
Connection	integrated cable, axial, standard length 3 m; 1 m, 6 m, 9 m optional ⁵⁾			
Mounting	Cable gland (M12)	Cable gland (M18)	Cable gland (M18)	Cable gland (M24)
Temperature range	Storage	-20 ... +200 °C	-20 ... +200 °C	-20 ... +200 °C
	Operation	-20 ... +200 °C	-20 ... +200 °C	-20 ... +200 °C
Pressure resistance	20 bar front and rear			
Shock (DIN EN 60068-2-27)	15 g / 6 ms in 3 axes, 2 directions and 1000 shocks each			
Vibration (DIN EN 60068-2-6)	15 g / 49.85 ... 2000 Hz in 3 axes ±3 mm / 10 ... 49.85 Hz in 3 axes			
Protection class (DIN-EN 60529)	IP68 (plugged)			
Material	stainless steel and plastic			
Weight ⁶⁾	approx. 12 g	approx. 30 g	approx. 33 g	approx. 62 g

¹⁾ Valid for operation with DT306x controller, referred to nominal measuring range
²⁾ Relates to the mid of the measuring range, in the compensated temperature range
³⁾ RMS value of the signal noise, static (20 Hz)
⁴⁾ Only with DT3061 controller and 5-point linearization
⁵⁾ Length tolerance cable: nominal value - 0 % / + 30 %
⁶⁾ Weight only sensor without nuts without cable

Additional design: ES-U3-T

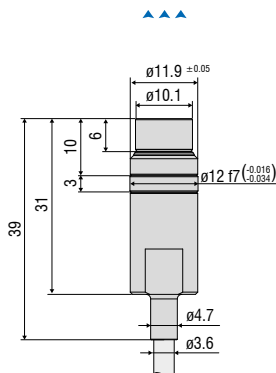

Connection of sensors with integrated cable:

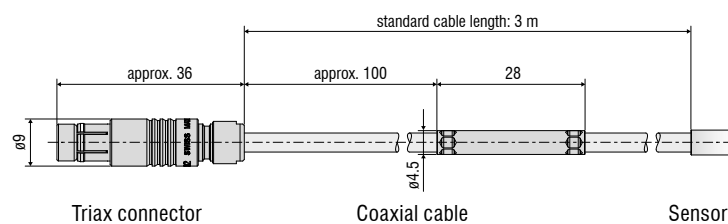

Cables

eddyNCDT 3060

Connection cable for DT3060 portfolio sensors

Sensors with integrated cable: cable type ES-xx-C-CAx



Coaxial cable with Viton sheathing

Cable diameter: Ø 3.6 mm

Minimum bending radius: static approx. 27 mm / dynamic approx. 54 mm

Temperature resistance: up to 200 °C

Available length: 1 m / 3 m / 6 m (9 m on request)

Sensors with socket: cable type EC-x/mB0/mB0



Coaxial cable with Viton sheathing

Cable diameter: Ø 3.6 mm

Minimum bending radius: static approx.27 mm / dynamic approx. 54 mm

Temperature resistance: up to 200 °C

Available length: 1 m / 3 m / 6 m (9 m on request)

Extension cable: cable type ECE-x/fB0/mB0

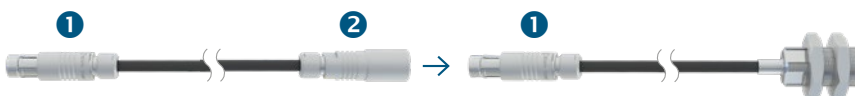

Coaxial cable with Viton sheathing

Cable diameter: Ø 3.6 mm

Minimum bending radius: static approx.27 mm / dynamic approx. 54 mm

Temperature resistance: up to 200 °C

Available length: 3 m / 6 m (9 m on request)



Plug/Socket

1 Connector Triax 0323118: Type S 102 A014-120 D4,1

Triaxial connector:

Type: mB0

Connection: push-pull

Temperature resistance: 200 °C



2 Socket Triax 0323141: Type KE102 A014-120 D4,1

Triaxial socket:

Type: fB0









Connection: push-pull

Temperature resistance: 200 °C



High-performance inductive displacement measuring system for miniature sensors

eddyNCDT 3070

-  Wide range of applications with numerous sensor models
-  High temperature stability
-  High resolution & linearity
-  Frequency response 20 kHz (-3dB)
-  Measuring rate 200 kSa/s
-  Sensors for ferromagnetic and non-ferromagnetic targets
-  Analog output (U/I)
Digital output
-  Intuitive configuration via web interface



Performance and universality for industrial use

The eddyNCDT 3070 is a powerful, inductive sensor system based on eddy currents for measuring ranges smaller than 1 mm. The system comprises a compact controller, a sensor and an integrated cable and is factory-calibrated either for ferromagnetic or non-ferromagnetic materials.

Ideal for integration into plant and machinery

As sensor and controller are temperature-compensated, a high measurement accuracy can be achieved even in fluctuating temperatures. The sensors are designed for ambient temperatures up to a maximum of +200 °C and an ambient pressure up to 700 bar. The compact controller design as well as the sensor robustness make the measuring system ideal for integration into plant and machinery.

New benchmark in controller technology

The industrial-grade M12 Ethernet interface offers a modern fieldbus connection. Configurable analog outputs enable to output the measured values as voltage or current. For multi-system operation, the systems come with a new kind of frequency separation (LF/HF) which enables to operate several sensors next to one another without requiring any synchronization.

Features	Controller type	
	DT3070	DT3071
Active temperature compensation for sensor and controller	✓	✓
Frequency separation (LF & HF)	✓	✓
Ethernet interface	✓	✓
Intuitive web interface	✓	✓
Multipoint calibration regardless of the distance (up to 3-point calibration)	✓	✓
Scalable measuring range via analog output (teach function)	✓	✓
Scalable analog output	✓	✓
Switching and temperature outputs	-	✓
5-point calibration	-	✓
Storage of multiple characteristic curves	-	✓



When connecting a PC via the Ethernet interface, a modern web interface can be accessed without any further installation and enables the parameterization of sensor and controller. The DT3071 controller provides enhanced features such as 5-point calibration, setting of switching and temperature outputs, as well as storage of multiple characteristic curves.

Model		DT3070	DT3071
Resolution ¹⁾	static (20 Hz)		0.005 % FSO
	dynamic (20 kHz)		0.025 % FSO
Frequency response (-3dB)		selectable (20 kHz, 5 kHz, 20 Hz)	
Measuring rate	Analog output	200 kSa/s (16 bit)	
	Digital interface	50 kSa/s (16 bit)	
Linearity ²⁾		< ±0.2 % FSO	< ±0.1 % FSO
Temperature stability ³⁾		< 0.05 % FSO / K	
Temperature compensation		+10 ... +50 °C	
Target material ⁴⁾		Steel, aluminum	
No. of characteristic curves		1	max. 4
Supply voltage		12 ... 32 VDC	
Power consumption		typ. 2.5 W (max. 2.8 W)	
Digital interface		Ethernet	Ethernet / selectable: switching output (TTL), temperature output (0...5 V)
Analog output		0 ... 10 V; 4 ... 20 mA (short circuit proof)	
Connection		Sensor: plug connector triaxial socket; supply/signal: 8-pole M12 connector; Ethernet: 5-pole M12 connector (cable see accessories)	
Mounting		through bores	
Temperature range	Storage	-10 ... +70 °C	
	Operation	0 ... +50 °C	
Shock (DIN EN 60068-2-27)		15 g / 6 ms in 3 axes, 2 directions and 1000 shocks each	
Vibration (DIN-EN 60068-2-6)		5 g / 10 ... 500 Hz in 3 axes, 2 directions and 10 cycles each	
Protection class (DIN-EN 60529)		IP67 (plugged)	
Material		Die-cast aluminum	
Weight		approx. 230 g	

FSO = Full Scale Output

¹⁾ RMS noise relates to mid of measuring range

²⁾ Value with 3-/5-point linearization

³⁾ Relates to mid of measuring range, in the compensated temperature range

⁴⁾ Steel: St37 Stahl DIN1.0037 / aluminum: AlMg3

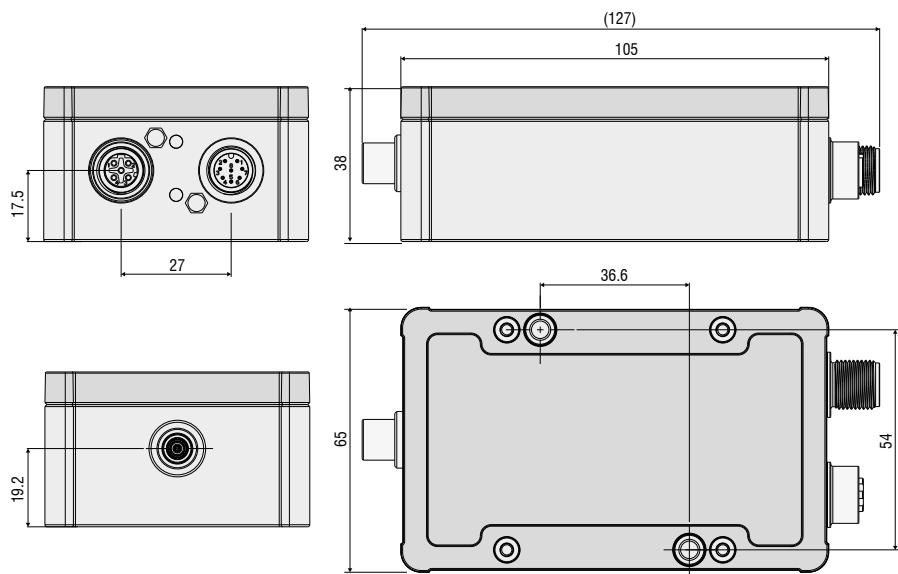

Pin assignment IN/OUT/24V IN

Pin	Assignment	Color (cable: PCx/8-M12)
1	Analog output U _{Displacement}	White
2	Supply +24 V	Brown
3	Limit value 1 / U _{Temp sensor}	Green
4	Limit value 2 / U _{Temp controller}	Yellow
5	GND Temperature, limit value	Gray
6	GND analog output	Pink
7	GND supply	Blue
8	Analog output I _{Displacement}	Red



8-pole M12x1 housing connector
View on pin side

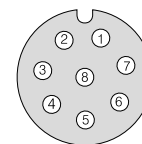

Dimensions in mm, not to scale.

Sensors

eddyNCDT 3070

▲▲▲
Measurement direction

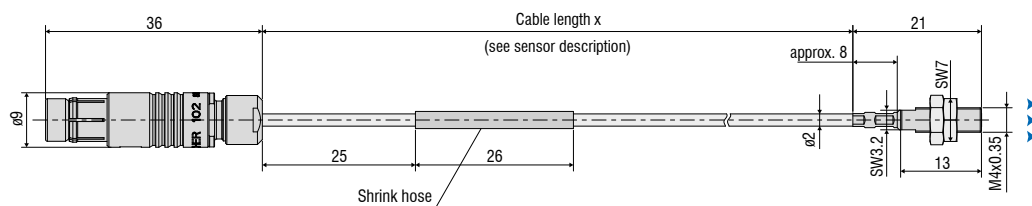

Model	ES-S04-C-CAx	
Measuring range	0.4 mm	
Start of measuring range	0.04 mm	
Resolution ^{1) 2) 3)}	0.02 μm	
Linearity ^{1) 4)}	< ±1 μm	
Temperature stability ^{1) 2)}	< 0.1 μm / K	
Temperature compensation	+10 ... +180 °C	
Sensor type	shielded	
Min. target size (flat)	Ø 5 mm	
Connection	integrated cable, axial, length 0.25 m, 0.5 m and 0.75 m ⁵⁾ bending radius: static ≥ 10 mm, dynamic ≥ 20 mm	
Mounting	Cable gland (M4)	
Temperature range	Storage	-20 ... +180 °C
	Operation	-20 ... +180 °C
Pressure resistance	100 bar (front)	
Shock (DIN EN 60068-2-27)	30 g	
Vibration (DIN EN 60068-2-6)	15 g	
Protection class (DIN-EN 60529)	IP50	
Material	stainless steel and ceramics	
Weight	approx. 25 g	

¹⁾ Valid for operation with DT307x controller, referred to nominal measuring range

²⁾ Relates to the mid of the measuring range, in the compensated temperature range

³⁾ RMS value of the signal noise, static (20 Hz)

⁴⁾ Only with DT307x controller and 3-point or 5-point linearization

⁵⁾ Length tolerance cable: ±0,03 m

Cables

eddyNCDT 3070

Connection cable for DT3070 portfolio sensors

Sensors with integrated cable: ES-S04-C-CAx/mB0/D2,0

and extension cable: ECE-x/fB0/mB0/D3,6



	Coaxial cable (extension cable)	Coaxial cable (sensor cable)
Cable diameter	Ø 3.6 mm	Ø 2 mm
Minimum bending radius	static approx. 27 mm / dynamic approx. 54 mm	static approx. 10 mm / dynamic approx. 20 mm
Temperature resistance	up to 200 °C	static up to 200 °C
Available length	1 m / 3 m (6 m on request)	0.25 m / 0.5 m / 0.75 m

Sensors with integrated cable and open ends

for solder connection via adapter cable: ECA-x/OE/mB0/D3,6



Coaxial cable with Viton sheathing

Cable diameter: Ø 3.6 mm
 Minimum bending radius: static approx. 27 mm / dynamic approx. 54 mm
 Temperature resistance: up to 200 °C
 Available length: 1 m / 3 m (6 m on request)

Sensors with integrated cable and A0 plug via adapter cable:

ECA-x/mA0/mB0/D3,6



Coaxial cable with Viton sheathing

Cable diameter: Ø 3.6 mm
 Minimum bending radius: static approx. 27 mm / dynamic approx. 54 mm
 Temperature resistance: up to 200 °C
 Available length: 1 m / 3 m (6 m on request)



Plug/Socket:

1 Triax plug 0323118:

Type S 102 A014-120 D4,1
 Triaxial plug: Type: mB0
 Connection: push-pull
 Temperature resistance: 200 °C



2 Triax socket 0323141:

Type KE102 A014-120 D4,1
 Triaxial socket: Type: fB0
 Connection: push-pull
 Temperature resistance: 200 °C



3 Triax plug 0323727:

Type S 102 A014-120 D2,1
 Triaxial plug: Type: mB0
 Connection: push-pull
 Temperature resistance: 200 °C



4 Triax plug 0323174:

Type S101 A005-120 D4,1
 Triaxial plug: Type: mA0
 Connection: push-pull
 Temperature resistance: 150 °C







5 Triax socket 0323173

Triaxial socket: Type: fA0
 Connection: push-pull
 Temperature resistance: 150 °C



High precision eddy current displacement measurement

eddyNCDT 3300

-  High resolution & linearity
-  High speed measurements: up to 100 kHz (-3dB) frequency response
-  Numerous sensor models even for customer-specific applications
-  Sensors for ferromagnetic and non-ferromagnetic targets



The eddyNCDT 3300 eddy current system is a powerful displacement measuring system which offers numerous benefits in manufacturing automation, machine monitoring and quality control.

Multifunctional controller

The eddyNCDT 3300 controller is equipped with high performance processors for reliable signal processing and further processing. The three-point linearization feature enables almost fully automatic field linearization, which provides high accuracy for any metallic target and installation environment. The operation is supported by a dialog-aided graphical display.

Highest frequency response

Monitoring highly dynamic processes is possible with the eddyNCDT 3300 which offers a frequency response of 100 kHz. This enables to solve measurement tasks where high measurement speeds and high accuracy are required.

Model	DT3300	DT3301
Resolution ¹⁾	static (25 Hz)	0.005 % FSO (≤ 0.01 % FSO with ES04, ES05 and EU05)
	dynamic (25 / 100 kHz)	0.2 % FSO
Frequency response (-3dB)	selectable 25 kHz, 2.5 kHz, 25 Hz; 100 kHz for measuring ranges ≤ 1 mm	
Linearity	$< \pm 0.2$ % FSO	
Temperature compensation ²⁾	+10 ... 100 °C (option TCS: -40 ... +180 °C)	
Target material ³⁾	Steel, aluminum	
Supply voltage	± 12 VDC and 5.2 VDC ⁴⁾	11 ... 32 VDC
Max. current consumption	approx. 420 mA	700 mA
Analog output	selectable 0 ... 5 V; 0 ... 10 V; ± 2.5 V; ± 5 V; ± 10 V (or inverted); / 4 ... 20 mA (short circuit proof)	
Connection	Sensor: pluggable cable via 5-pole socket Supply/signal: 8-pole M16 x 0.75 connector (cable see accessories)	
Temperature range	Storage	-25 ... +70 °C
	Operation	+5 ... +50 °C
Protection class (DIN EN 60529)	IP64 (plugged)	
Control and display elements	limit value monitoring, auto-zero, peak-to-peak, minimum, maximum, average, storage of 3 characteristics	

FSO = Full Scale Output

¹⁾ Resolution data are based on noise peak-to-peak values

²⁾ Temperature stability may differ with TCS option

³⁾ Steel: St37 steel DIN1.0037 / aluminum: AlMg3

⁴⁾ Additionally 24 VDC for external reset and limit switch

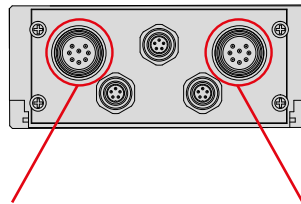
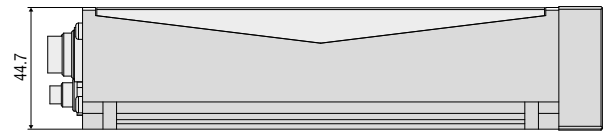
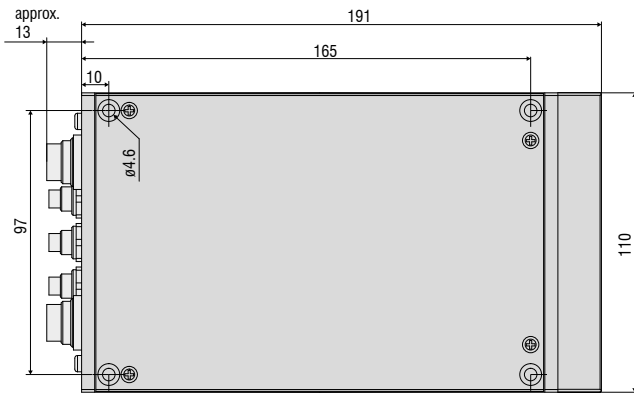

Dimensions in mm, not to scale.

Pin assignment ANALOG - I/O

Pin	Assignment	Color (cable: SCA3/5)
1	n.c.	---
2	n.c.	---
3	Analog output U _{OUT}	Brown
4	n.c.	---
5	Temperature output ¹⁾ U _{Temp}	Green
6	n.c.	Gray
7	Agnd	White
8	Analog output I _{OUT}	Yellow

¹⁾ Signal available only as option

Pin assignment IN/OUT/24V IN

Pin	Assignment	Color (cable: SCD3/8)
1	Zeroing In	Brown
2	Limit value A Out	Yellow
3	n.c.	Blue
4	Reset limit value In	Green
5	n.c.	Pink
6	24 VDC ground	White
7	+24 VDC in	Red
8	Limit value B Out	Gray

8-pin cable connector
View on solder side

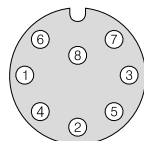

8-pin cable connector
View on solder side

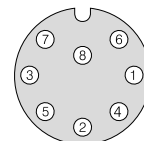

Sensors

eddyNCDT 3300

▲▲▲▲
Measurement direction

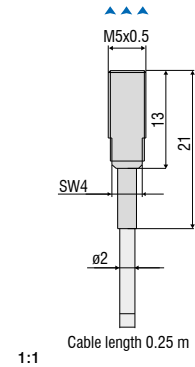
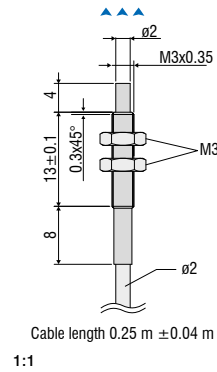
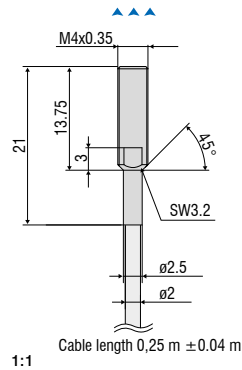

Model		ES04	EU05	ES08
Measuring range		0.4 mm	0.4 mm	0.8 mm
Start of measuring range		0.04 mm	0.05 mm	0.08 mm
Resolution ^{1) 2) 3)}		0.04 μm	0.05 μm	0.04 μm
Linearity ¹⁾		$< \pm 0.8 \mu\text{m}$	$< \pm 1 \mu\text{m}$	$< \pm 1.6 \mu\text{m}$
Temperature stability ^{1) 2) 4)}		$< 0.06 \mu\text{m} / \text{K}$	$< 0.075 \mu\text{m} / \text{K}$	$< 0.12 \mu\text{m} / \text{K}$
Temperature compensation ⁴⁾		0 ... +90 °C	0 ... +90 °C	0 ... +90 °C
Min. target size (flat)		$\varnothing 6 \text{ mm}$	$\varnothing 9 \text{ mm}$	$\varnothing 7.5 \text{ mm}$
Sensor type		shielded	unshielded	shielded
Connection		integrated cable, axial, length approx. 0.25 m ⁵⁾	integrated cable, axial, length approx. 0.25 m ⁵⁾	integrated cable, axial, length approx. 0.25 m ⁵⁾
Mounting		Cable gland (M4)	Cable gland (M3)	Cable gland (M5)
Temperature range	Storage	-20 ... +150 °C	-20 ... +150 °C	-20 ... +150 °C
	Operation	0 ... +150 °C	0 ... +150 °C	0 ... +150 °C
Pressure resistance		100 bar (front)	-	20 bar (front)
Protection class (DIN EN 60529)		IP64 (plugged)	IP64 (plugged)	IP64 (plugged)
Material		stainless steel	stainless steel and ceramics	stainless steel and plastic

¹⁾ Valid for operation with DT3300 controller, referred to nominal measuring range

²⁾ Relates to mid of measuring range

³⁾ RMS value of the signal noise, static (25 Hz)

⁴⁾ Higher values possible with TCS option

⁵⁾ Length tolerance of cable: $\pm 10 \%$

▲▲▲▲
Measurement direction
▲
Connector side

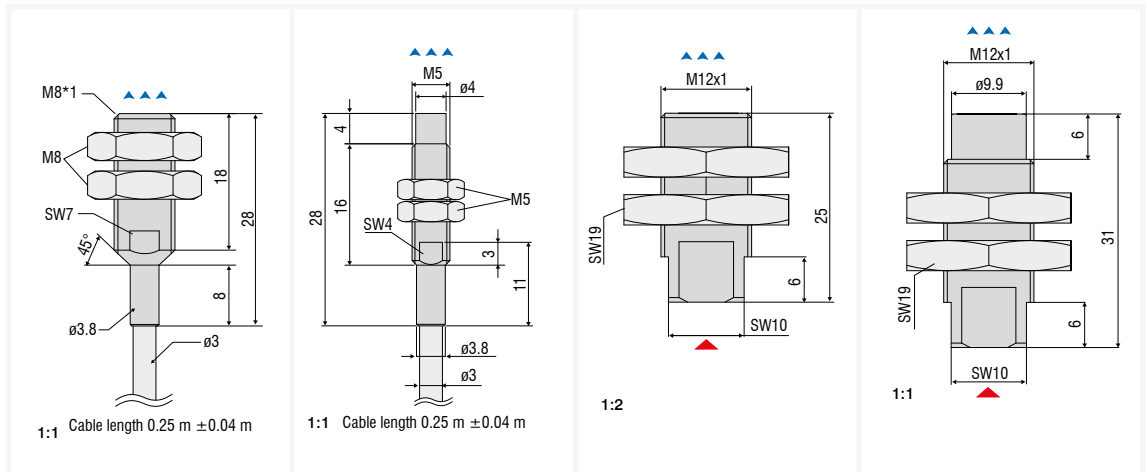

Model	ES1	EU1	ES2	EU3
Measuring range	1 mm	1 mm	2 mm	3 mm
Start of measuring range	0.1 mm	0.1 mm	0.2 mm	0.3 mm
Resolution ^{1) 2) 3)}	0.05 μm	0.05 μm	0.1 μm	0.15 μm
Linearity ¹⁾	$< \pm 2 \mu\text{m}$	$< \pm 2 \mu\text{m}$	$< \pm 4 \mu\text{m}$	$< \pm 6 \mu\text{m}$
Temperature stability ^{1) 2) 4)}	$< 0.15 \mu\text{m} / \text{K}$	$< 0.15 \mu\text{m} / \text{K}$	$< 0.3 \mu\text{m} / \text{K}$	$< 0.45 \mu\text{m} / \text{K}$
Temperature compensation ⁴⁾	0 ... +90 °C	0 ... +90 °C	0 ... +90 °C	0 ... +90 °C
Min. target size (flat)	$\varnothing 12 \text{ mm}$	$\varnothing 15 \text{ mm}$	$\varnothing 18 \text{ mm}$	$\varnothing 36 \text{ mm}$
Sensor type	shielded	unshielded	shielded	unshielded
Connection	integrated cable, axial, length approx. 0.25 m ⁵⁾	integrated cable, axial, length approx. 0.25 m ⁵⁾	Plug connection via triaxial socket	Plug connection via triaxial socket
Mounting	Cable gland (M8)	Cable gland (M5)	Cable gland (M12)	Cable gland (M12)
Temperature range	Storage	-20 ... +150 °C	-20 ... +150 °C	-20 ... +150 °C
	Operation	0 ... +150 °C	-40 ... +150 °C	-20 ... +150 °C
Pressure resistance	-	-	20 bar (front)	20 bar (front)
Protection class (DIN EN 60529)	IP64 (plugged)	IP50 (plugged)	IP64 (plugged)	IP64 (plugged)
Material	stainless steel and plastic	stainless steel and plastic	stainless steel and plastic	stainless steel and plastic

¹⁾ Valid for operation with DT3300 controller, referred to nominal measuring range

²⁾ Relates to mid of measuring range

³⁾ RMS value of the signal noise, static (25 Hz)

⁴⁾ Higher values possible with TCS option

⁵⁾ Length tolerance of cable: $\pm 10 \%$

Sensors

eddyNCDT 3300

▲▲▲▲
Measurement direction

▲
Connector side

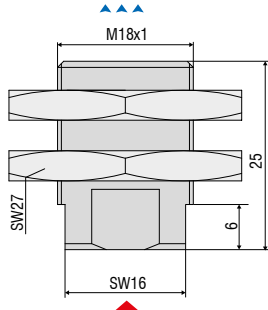

1:1

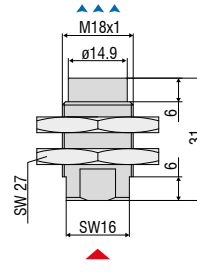

1:2

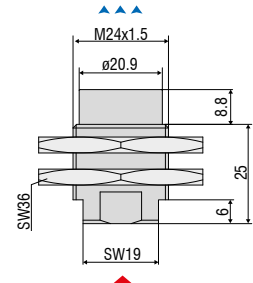

1:2

Model		ES4	EU6	EU8
Measuring range		4 mm	6 mm	8 mm
Start of measuring range		0.4 mm	0.6 mm	0.8 mm
Resolution ^{1) 2) 3)}		0.2 μm	0.3 μm	0.4 μm
Linearity ¹⁾		< ±8 μm	< ±12 μm	< ±16 μm
Temperature stability ^{1) 2) 4)}		< 0.6 μm / K	< 0.9 μm / K	< 1.2 μm / K
Temperature compensation ⁴⁾		0 ... +90 °C	0 ... +90 °C	0 ... +90 °C
Min. target size (flat)		Ø 27 mm	Ø 54 mm	Ø 72 mm
Sensor type		shielded	unshielded	unshielded
Connection		Plug connection via triaxial socket	Plug connection via triaxial socket	Plug connection via triaxial socket
Mounting		Cable gland (M18)	Cable gland (M18)	Cable gland (M24)
Temperature range	Storage	-20 ... +150 °C	-20 ... +150 °C	-20 ... +150 °C
	Operation	0 ... +150 °C	-20 ... +150 °C	0 ... +150 °C
Pressure resistance		20 bar (front)	20 bar (front)	20 bar (front)
Protection class (DIN EN 60529)		IP50 (plugged)	IP64 (plugged)	IP64 (plugged)
Material		stainless steel and plastic	stainless steel and plastic	stainless steel and plastic

¹⁾ Valid for operation with DT3300 controller, referred to nominal measuring range

²⁾ Relates to mid of measuring range

³⁾ RMS value of the signal noise, static (25 Hz)

⁴⁾ Higher values possible with TCS option

▲▲▲▲
Measurement direction

▲
Connector side

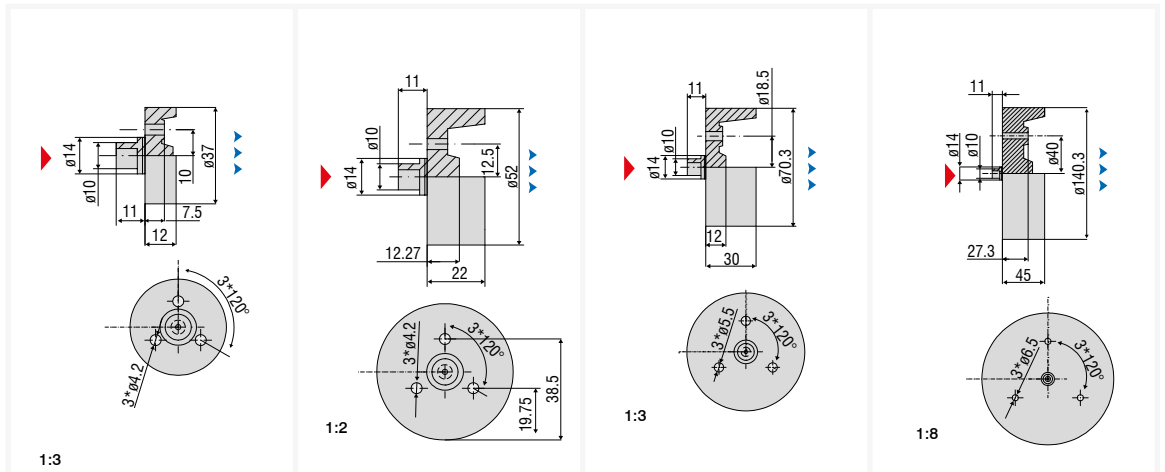

Model		EU15	EU22	EU40	EU80
Measuring range		15 mm	22 mm	40 mm	80 mm
Start of measuring range		1.5 mm	2.2 mm	4 mm	8 mm
Resolution ^{1) 2) 3)}		0.75 μm	1.1 μm	2 μm	4 μm
Linearity ¹⁾		< $\pm 30 \mu\text{m}$	< $\pm 44 \mu\text{m}$	< $\pm 80 \mu\text{m}$	< $\pm 160 \mu\text{m}$
Temperature stability ^{1) 2) 4)}		< 2.25 $\mu\text{m} / \text{K}$	< 3.3 $\mu\text{m} / \text{K}$	< 6 $\mu\text{m} / \text{K}$	< 12 $\mu\text{m} / \text{K}$
Temperature compensation ⁴⁾		0 ... +90 °C	0 ... +90 °C	0 ... +90 °C	0 ... +90 °C
Min. target size (flat)		$\varnothing 111 \text{ mm}$	$\varnothing 156 \text{ mm}$	$\varnothing 210 \text{ mm}$	$\varnothing 420 \text{ mm}$
Sensor type		unshielded	unshielded	unshielded	unshielded
Connection		Plug connection via triaxial socket	Plug connection via triaxial socket	Plug connection via triaxial socket	Plug connection via triaxial socket
Mounting		3 x through-holes	3 x through-holes	3 x through-holes	3 x through-holes
Temperature range	Storage	-20 ... +150 °C	-20 ... +150 °C	-20 ... +150 °C	-20 ... +150 °C
	Operation	0 ... +150 °C	0 ... +150 °C	0 ... +150 °C	0 ... +150 °C
Protection class (DIN EN 60529)		IP64 (plugged)	IP64 (plugged)	IP64 (plugged)	IP64 (plugged)
Material		epoxy	epoxy	epoxy	epoxy

¹⁾ Valid for operation with DT3300 controller, referred to nominal measuring range

²⁾ Relates to mid of measuring range

³⁾ RMS value of the signal noise, static (25 Hz)

⁴⁾ Higher values possible with TCS option

Cables

eddyNCDT 3300

Connection cables for DT3300 portfolio sensors

Sensors with integrated cable:
cable types ECx + ESx or EUx

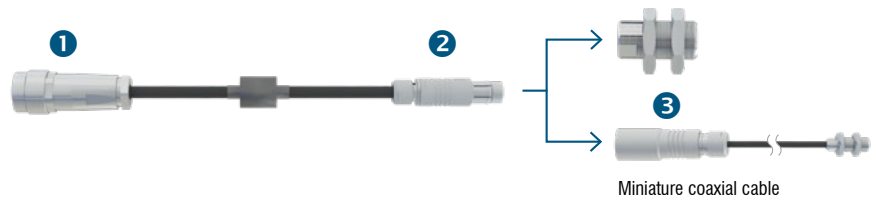

Special coaxial cable

Coaxial cable with fluorothermoplastic sheath
Cable diameter: Ø 3.9 mm
Minimum bending radius: static approx. 20 mm / dynamic approx. 40 mm
Temperature resistance: up to 130 °C
Available length: 1 m / 3 m / 6 m

Sensors with integrated cable and open ends
for solder connection via adapter cable: ECx/1



Special coaxial cable

Coaxial cable with fluorothermoplastic sheath
Cable diameter: Ø 3.9 mm
Minimum bending radius: static approx. 20 mm / dynamic approx. 40 mm
Temperature resistance: up to 130 °C
Available length: 1 m / 3 m / 6 m

Sensors with integrated cable and A0 plug
via adapter cable: ECx/2



Special coaxial cable

Coaxial cable with fluorothermoplastic sheath
Cable diameter: Ø 3.9 mm
Minimum bending radius: static approx. 20 mm / dynamic approx. 40 mm
Temperature resistance: up to 130 °C
Available length: 1 m / 3 m / 6 m



Plug/Socket

1 5-pole socket 0323109: series 712

Type: 5 poles

Connection: screwed connector

Temperature resistance: 85 °C



2 Triax plug 0323253: Type SE102 A014-120 D4,9

Triaxial plug: Type: mB0

Connection: push-pull

Temperature resistance: 150 °C



3 Triax socket 0323121: Type KE102 A014-120 D2,1

Triaxial socket: Type: fB0

Connection: push-pull

Temperature resistance: 130 °C



4 Triax plug 0323174: Type S101 A005-120 D4,1

Triaxial plug: Type: mA0

Connection: push-pull

Temperature resistance: 150 °C



5 Triax socket 0323173

Triaxial socket: Type: fA0

Connection: push-pull

Temperature resistance: 150 °C

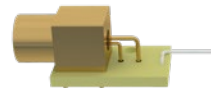

Sensors for special applications

eddyNCDT 3300

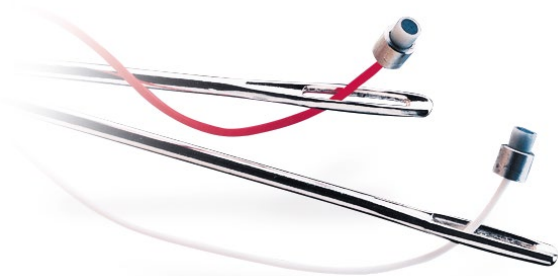

Subminiature sensors for restricted spaces

As well as standard sensors in conventional designs, miniature sensors with the smallest possible dimensions that achieve high precision measurement results are also available. Pressure-resistant versions, screened housings, ceramic types and other special features characterize these sensors, which achieve highly accurate measurement results despite their small dimensions. These miniature sensors are primarily used in high pressure applications, for example, in combustion engines.

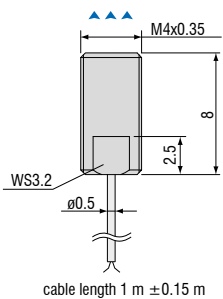

ES04/180(25) Shielded Sensor

Measuring range 0.4 mm
 Temperature stability $\leq \pm 0.025\%$ FSO/°C
 Connection: integrated coaxial cable 1 m ($\varnothing 0.5$ mm), short silicon tube at cable exit
 Pressure resistance (static): front 100 bar
 Max. operating temperature: 180 °C
 Housing material: stainless steel
 Sensor cable: ECx/1 or ECx/2, length ≤ 6 m

2:1

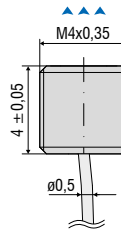

ES04/180(102) Shielded Miniature Sensor

Measuring range 0.4 mm
 Temperature stability $\leq \pm 0.025\%$ FSO/°C
 Connection: integrated coaxial cable 0.8 m ($\varnothing 0.5$ mm) with solder connection board
 Pressure resistance (static): front 100 bar / rear side splash water
 Max. operating temperature: 150 °C
 Housing material: stainless steel and ceramic
 Sensor cable: ECx/1, length ≤ 6 m

3:1

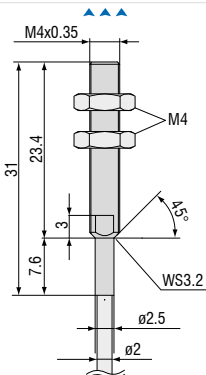

ES04(34) Shielded Sensor

Measuring range 0.4 mm
 Temperature stability $\leq \pm 0.025\%$ FSO/°C
 Connection: integrated coaxial cable 0.25 m ($\varnothing 2$ mm) with sealed triaxial connector
 Pressure resistance (static): front 100 bar / rear side splash water
 Max. operating temperature: 150 °C
 Housing material: stainless steel and ceramic
 Sensor cable: ECx, length ≤ 6 m

1:1

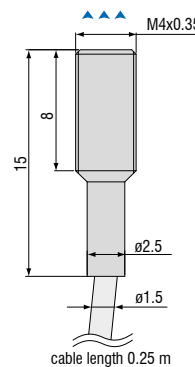

ES04(35) Shielded Sensor

Measuring range 0.4 mm
 Temperature stability $\leq \pm 0.025\%$ FSO/°C
 Connection: integrated coaxial cable 0.25 m ($\varnothing 1.5$ mm) with sealed triaxial connector
 Pressure resistance (static): front 100 bar / rear side 5 bar
 Max. operating temperature: 150 °C
 Housing material: stainless steel and ceramic
 Sensor cable: ECx/1, length ≤ 6 m

2:1

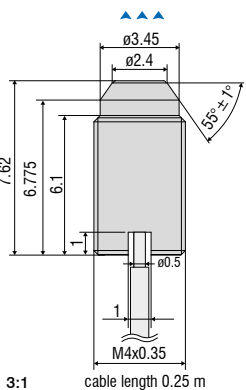

ES04(70) Shielded Sensor

Measuring range 0.4 mm
 Temperature stability $\leq \pm 0.025\%$ FSO/°C
 Connection: integrated coaxial cable 0.25 m ($\varnothing 0.5$ mm) with solder connection board
 Pressure resistance (static): front 100 bar / rear side splash water
 Max. operating temperature: 150 °C
 Housing material: stainless steel and ceramic
 Sensor cable: ECx/1, length ≤ 6 m

3:1

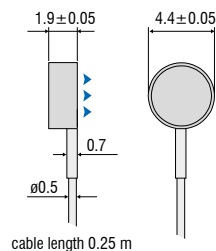

ES05/180(16) Shielded Sensor

Measuring range 0.5 mm
 Temperature stability $\leq \pm 0.025\%$ FSO/°C
 Connection: integrated coaxial cable 0.25 m ($\varnothing 0.5$ mm) with solder connection board
 Max. operating temperature: 180 °C
 Housing material: stainless steel and epoxy
 Sensor cable: ECx/1, length ≤ 6 m

3:1

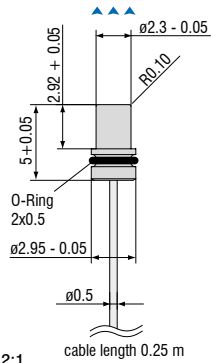

EU05(65) Unshielded Sensor

Measuring range 0.5 mm
 Connection: integrated coaxial cable 0.25 m
 (\varnothing 0.5 mm) with solder connection board
 Pressure resistance (static):
 front 700 bar / rear side splash water
 Max. operating temperature: 150 °C
 Housing material: ceramic
 Sensor cable: ECx/1, length \leq 6 m

2:1

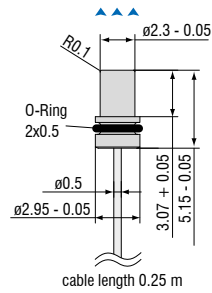

EU05(93) Unshielded Sensor

Measuring range 0.4 mm
 Temperature stability $\leq \pm 0.025$ % FSO/°C
 Connection: integrated coaxial cable 0.25 m
 (\varnothing 0.5 mm) with solder connection board
 Pressure resistance (static):
 front 2000bar / rear side splash water
 Max. operating temperature: 150 °C
 Housing material: ceramic
 Sensor cable: ECx/1, length \leq 6 m

2:1

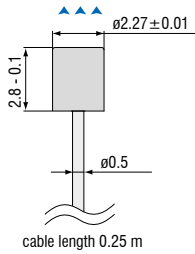

EU05(66) Unshielded Sensor

Measuring range 0.5 mm
 Temperature stability $\leq \pm 0.025$ % FSO/°C
 Connection: integrated coaxial cable 0.25 m
 (\varnothing 0.5 mm) with solder connection board
 Pressure resistance (static):
 front 400 bar / rear side splash water
 Max. operating temperature: 150 °C
 Housing material: ceramic
 Sensor cable: ECx/1, length \leq 6 m

3:1

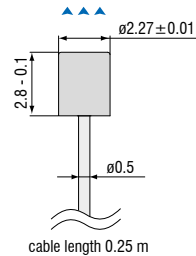

EU05(72) Unshielded Sensor

Measuring range 0.4 mm
 Temperature stability $\leq \pm 0.025$ % FSO/°C
 Connection: integrated coaxial cable 0.25 m
 (\varnothing 0.5 mm) with solder connection board
 Pressure resistance (static):
 front 2000 bar / rear side splash water
 Max. operating temperature: 150 °C
 Housing material: ceramic
 Sensor cable: ECx/1, length \leq 6 m

3:1

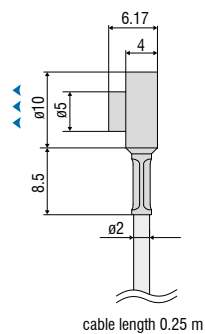







EU1FL Unshielded flat sensor

Measuring range 1 mm
 Temperature stability $\leq \pm 0,025$ % FSO/°C
 Connection: integrated coaxial cable 0.25 m
 (\varnothing 2 mm) with sealed triaxial connector
 Max. operating temperature: 150 °C
 Housing material: stainless steel and epoxy
 Sensor cable: ECx

1:1

Turbocharger speed measurement

turboSPEED DZ140

-  Speed range from 200 to 400,000 rpm
-  Miniature sensor $\varnothing 3$ mm
-  Measuring aluminum and titanium
-  Large distances up to 2.2 mm
-  Highest immunity to interference
-  Sensor operating temperature up to 285 °C



Measuring principle

A coil integrated in the sensor housing is energized by a high-frequency alternating current. The emerging electromagnetic field changes when approaching a turbo charger blade. This is how every blade generates a pulse. The controller identifies the rotational speed (analog 0 - 5 V) by considering the number of blades.

Robust miniature controller

As the entire controller is in a sealed miniature housing and designed for ambient temperatures up to 115 °C, the controller is easy to integrate into the engine compartment. The turboSPEED DZ140 offers excellent interference resistance for increased EMC requirements as well as in test cells and road tests.

Engine compartment application

The DZ140 eddy current measuring system is resistant to oil and dirt. This is a key advantage especially compared to optical speed measuring systems, as this immunity helps to achieve high precision measurements on a continuous basis.

Ease of use

A tri-color 'status' LED on the controller indicates when the sensor has reached the ideal distance from the turbocharger blades. This simple feature enables greatly reduced installation time. As the sensor is connected with the controller via a special BNC connector, it is therefore downward compatible with all previous sensor models. An industrial push-pull connector guarantees a reliable connection between the controller and the power supply as well as the analog outputs.

Measuring aluminum and titanium blades

The DZ140 measures both aluminum and titanium blades. The sensors can be mounted at a relatively large distance from the blade. The maximum distance of 2.2 mm enables reliable operation.



Extremely compact design

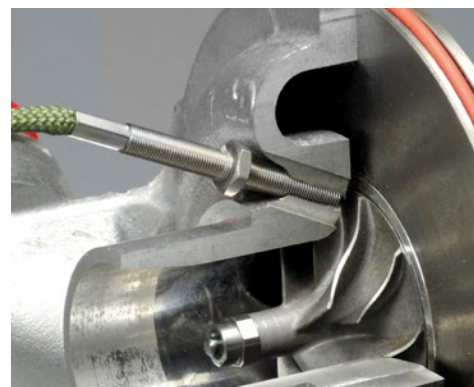

Large measuring distances both on aluminum and titanium

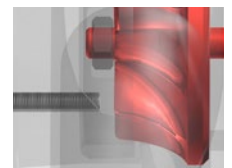

Axial installation

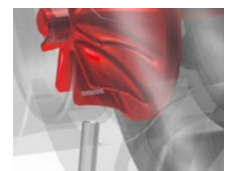

Radial installation

Model		DZ140
Resolution		10 bits
Speed range (measuring range)		200 ... 400,000 rpm
Linearity		< ±0.2 % FSO
Target material		aluminum or titanium
Supply voltage		9 ... 30 VDC (short-term up to 36 VDC)
Max. current consumption		50 mA
Digital output		TTL level (1 pulse / blade with variable pulse duration or 1 pulse / rotation with 100 μs pulse duration)
Analog output		0 ... 5 V ¹⁾
Connection		Sensor: triaxial connector; Supply/signal: 10-pole connector, raw signal: coaxial connector (cable see accessories)
Mounting		Screw connection with 4 through-holes
Temperature range	Storage	-40 ... +125 °C
	Operation	-40 ... +125 °C
Protection class (DIN EN 60529)		IP65 (plugged)
Weight		approx. 85 g
Number of blades		adjustable via rotary switch accessible from outside for 1 to 16 blades

FSO = Full Scale Output (speed range)

¹⁾ Rotational speed adjustable via mode rotary switch

Controller DZ140

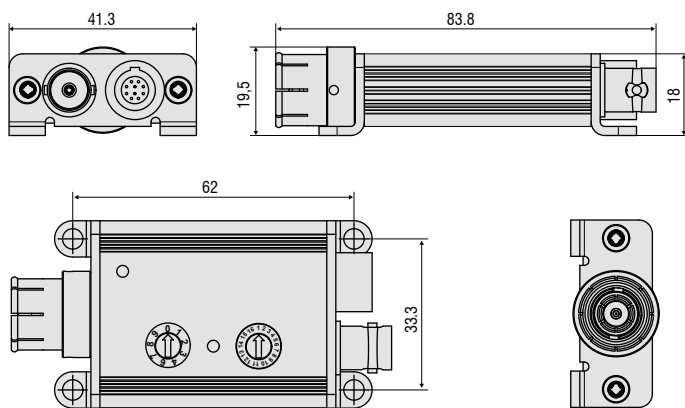

Dimensions in mm, not to scale.

Pin assignment for power supply and signal

Pin	Assignment	Color (cable: PC140-x)
1	Analog output for rotational speed 0 ... +5 V	Blue
2	reserved, not connected	Yellow
3	TTL pulses, digital	Green
4	reserved, not connected	-
5	GND	Black
6	reserved, not connected	-
7	Supply -	White
8	Supply voltage +9 ... 30 VDC	Brown
9	Not assigned	-
10	Not assigned	-

 10-pin cable connector
View on solder side

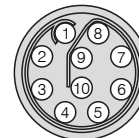

Sensors

turboSPEED DZ140

▲▲▲
Measurement direction

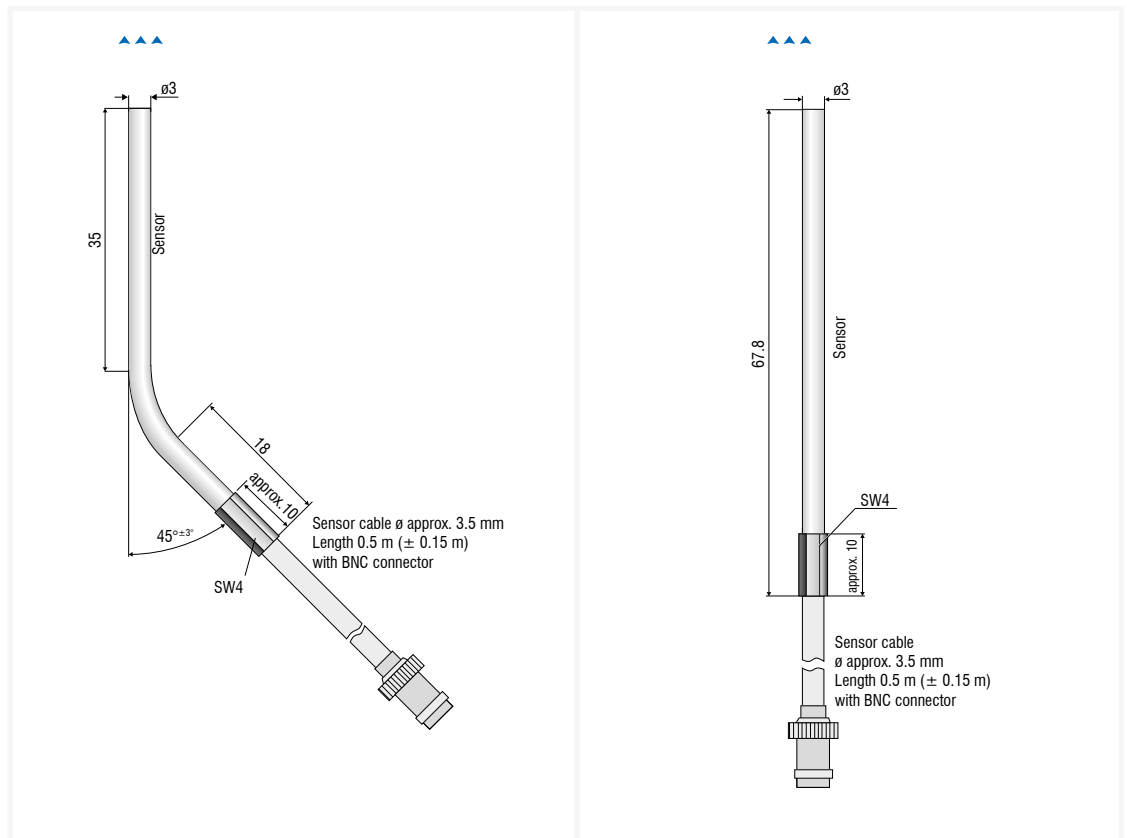

Model	DS 05(03)	DS 05(04)
Sensor type	shielded	shielded
Connection ¹⁾	integrated cable, axial, length 0.5 m	integrated cable, axial, length 0.5 m
Mounting	Clamping/adaptor	Clamping/adaptor
Temperature range	Storage	-40 ... +200 °C
	Operation	-40 ... +200 °C
Special feature	curved housing	-

¹⁾ Length tolerance ± 0.15 m

▲▲▲▲
Measurement direction

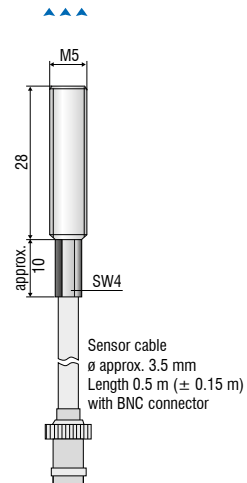
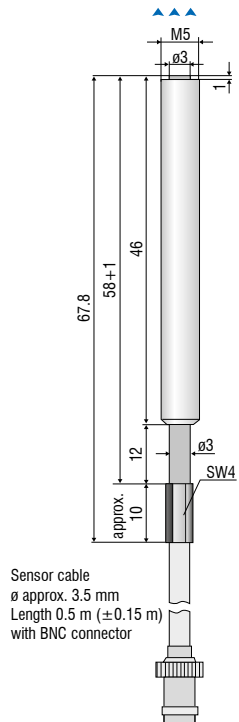

Model		DS 05(07)	DS 05(14)
Sensor type		shielded	shielded
Connection ¹⁾		integrated cable, axial, length 0.5 m	integrated cable, axial, length 0.5 m
Mounting		Cable gland (M5)	Cable gland (M5)
Temperature range	Storage	-40 ... +200 °C	-40 ... +200 °C
	Operation	-40 ... +200 °C	-40 ... +200 °C
Special feature		-	Length of housing 42.5 mm

¹⁾ Length tolerance ±0.15 m

Sensors

turboSPEED DZ140

▲▲▲▲
Measurement direction

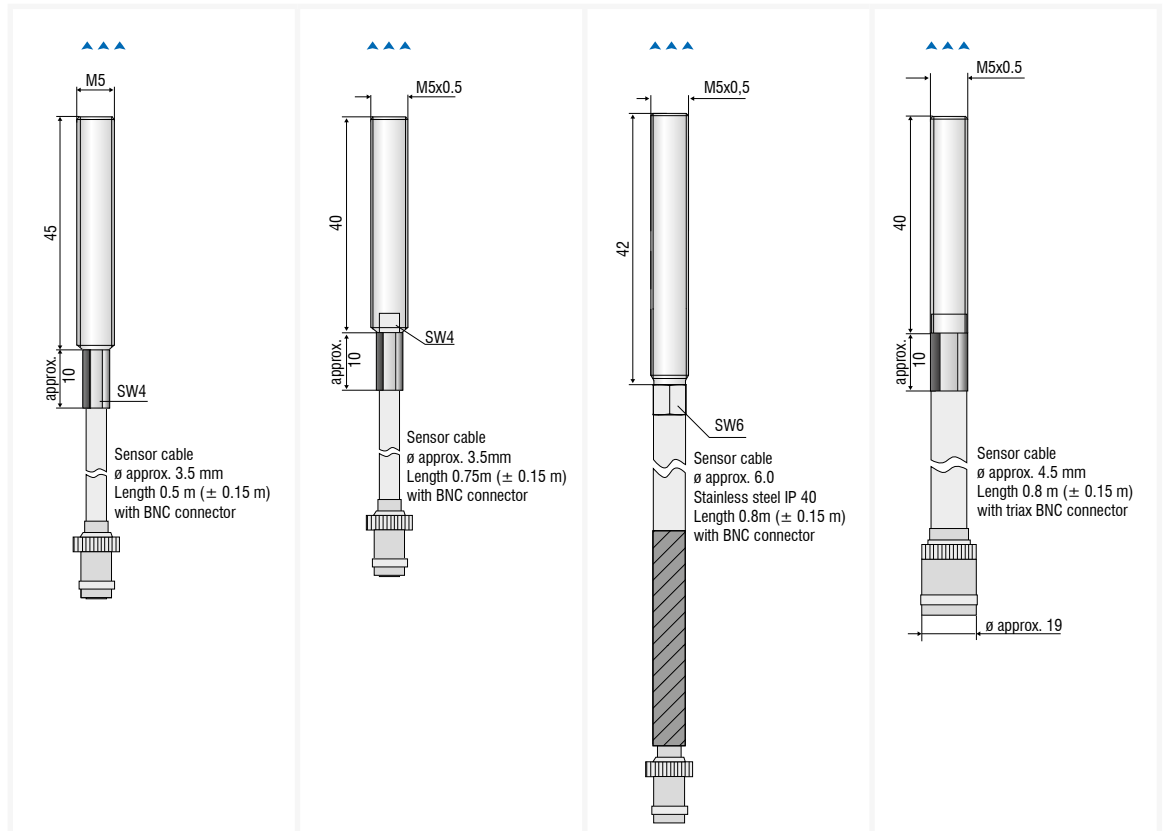

Model	DS 05(15)	DS 1	DS 1(04)	DS 1/T
Sensor type	shielded	shielded	shielded	shielded
Connection ¹⁾	integrated cable, axial, length 0.5 m	integrated cable, axial, length 0.75 m	integrated cable, axial, length 0.8 m	integrated cable, axial, length 0.8 m
Mounting	Cable gland (M5)	Cable gland (M5)	Cable gland (M5)	Cable gland (M5)
Temperature range	Storage	-40 ... +200 °C	-40 ... +235 °C	-40 ... +235 °C
	Operation	-40 ... +200 °C	-40 ... +235 °C	-40 ... +235 °C (short-term +285 °C)
Special feature	-	-	protective hose (stainless steel)	-

¹⁾ Length tolerance ± 0.15 m

Cables

turboSPEED DZ140

Connection cables for DZ140 portfolio sensors



Miniature coaxial cable for DS05(x) and DS1 models

Diameter: approx. 3.5 mm

Sheathing: thermal protection fabric hose (polyolefin shrink hose)

Temperature range: -50 °C to +200 °C (static)

Minimum bending radius: static approx. 18 mm / dynamic approx. 35 mm

Connection: BNC socket coaxial



Miniature coaxial cable for DS1(04) models

Diameter: approx. 6 mm

Sheathing: metallic protective hose (stainless steel)

Temperature range: -50 °C to +200 °C (static)

Minimum bending radius: static approx. 30 mm / dynamic approx. 60 mm

Connection: BNC socket coaxial

Protection class: IP 40



Triaxial cable for the DS1/T models

Diameter: approx. 3.5 mm

Sheathing: thermal protection fabric hose (polyolefin shrink hose)





Temperature range: -50 °C to +200 °C

Minimum bending radius: static approx. 18 mm / dynamic approx. 35 mm

Connection: BNC socket triaxial

Spindle Growth System

eddyNCDT SGS4701

-  Miniature sensor design
-  M12 controller - Integration into spindle or flange mounting
-  Sensors for ferromagnetic and non-ferromagnetic targets
-  Temperature measurement integrated



Measuring the thermal extension of spindles

The SGS4701 displacement measuring system (Spindle Growth System) is developed specifically for high speed milling machine applications. Due to high machining speeds and the heat generated, the linear thermal expansion of the spindle in precision machine tools needs to be compensated for in order to keep the tool in a defined position at all times. The SGS sensor measures the thermal and centrifugal force expansion of the spindle. These measurement values are fed into the CNC machine tool as correctional values, compensating for any positioning errors.

The SGS4701 operates on the eddy current measuring principle. This non-contact measurement method is wear-free. Furthermore, the measurement procedure is resistant to disturbances such as heat, dust and oil.

System design

The SGS 4701 consists of a sensor, a sensor cable and a controller, factory calibrated for ferromagnetic and non-ferromagnetic targets. Two miniature sensors enable it to be installed directly in the spindle, where the measurements take place, typically on the labyrinth-ring of the spindle. As well as measuring linear thermal expansion, the temperature of the sensor is also detected and output. The compact controller can be installed on the spindle housing via a flange or directly in the spindle.

The sensor cable must not be shortened as functionality loss may arise. Removing the connector is only permitted behind the plug-sided crimp when using the solder connections.

Customer-specific adjustment

For individual installation situations and measurement objects, sensor and controller can be adjusted in the factory. This enables to achieve the best possible measurement accuracy.

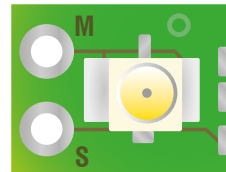

S = signal = inner conductor
M = ground = shield = outer conductor

Pin assignment for power supply and signal

Pin	Assignment	Color (cable: PC4701-x)
1	GND	White
2	Supply 12 ... 32 VDC	Brown
3	Displacement signal	Green
4	Temperature signal	Yellow
5	n.c.	Gray
6	internal	Pink
7	internal	Blue
8	n.c.	Red



8-pin housing connector M12x1
View on pin side

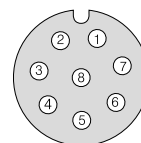

Model		SGS4701
Measuring range		500 μm (optional 250 μm ¹⁾)
Start of measuring range		100 μm (optional 50 μm ¹⁾)
Measuring rate	Analog output	64 kSa/s (16 bit)
Resolution ^{2) 3)}		0.5 μm
Frequency response (-3dB)		2000 Hz
Linearity		< $\pm 2 \mu\text{m}$
Temperature stability ³⁾	Sensor	< 150 ppm FSO / K
	Controller	< 500 ppm FSO / K
Temperature compensation	Sensor	+10 ... +80 °C
	Controller	+10 ... +70 °C
Min. target size (flat)		6 mm (optional 3.5 mm ¹⁾)
Target material ⁴⁾		Steel, aluminum
Supply voltage		12...32 VDC
Power consumption		0.6 W
Analog output	Displacement	0.5 ... 9.5 V (100 ... 600 μm , optional 50 ... 300 μm ¹⁾)
	Temperature	0.5 ... 9.5 V (0 ... 90 °C)
Connection		Sensor: integrated cable ⁵⁾ , standard length 1 m (0.4 ... 1.5 m on request), min. bending radius 12 mm Supply/signal: 8-pole M12 connector (cable see accessories)
Temperature range	Sensor	0 ... +90 °C
	Controller	+10 ... +70 °C
Shock (DIN EN 60068-2-27)		50 g / 6 ms in each direction, 1000 shocks each
Vibration (DIN EN 60068-2-6)		20 g / 10 ... 3000 Hz
Protection class (DIN EN 60529)		IP67 (plugged) ⁶⁾
Weight ⁷⁾		approx. 85 g

FSO = Full Scale Output

¹⁾ For OEM modifications: sensor with a measuring range of 250 μm and an offset of 50 μm are possible

²⁾ Static, relates to mid of measuring range

³⁾ Relates to mid of measuring range, in the compensated temperature range

⁴⁾ Steel: St37 steel DIN1.0037 / aluminum: AlMg3

⁵⁾ Detailed cable specifications can be found in the operating instructions

⁶⁾ Protection class does not apply for the controller sleeve!

⁷⁾ Total weight for controller, cable and sensor

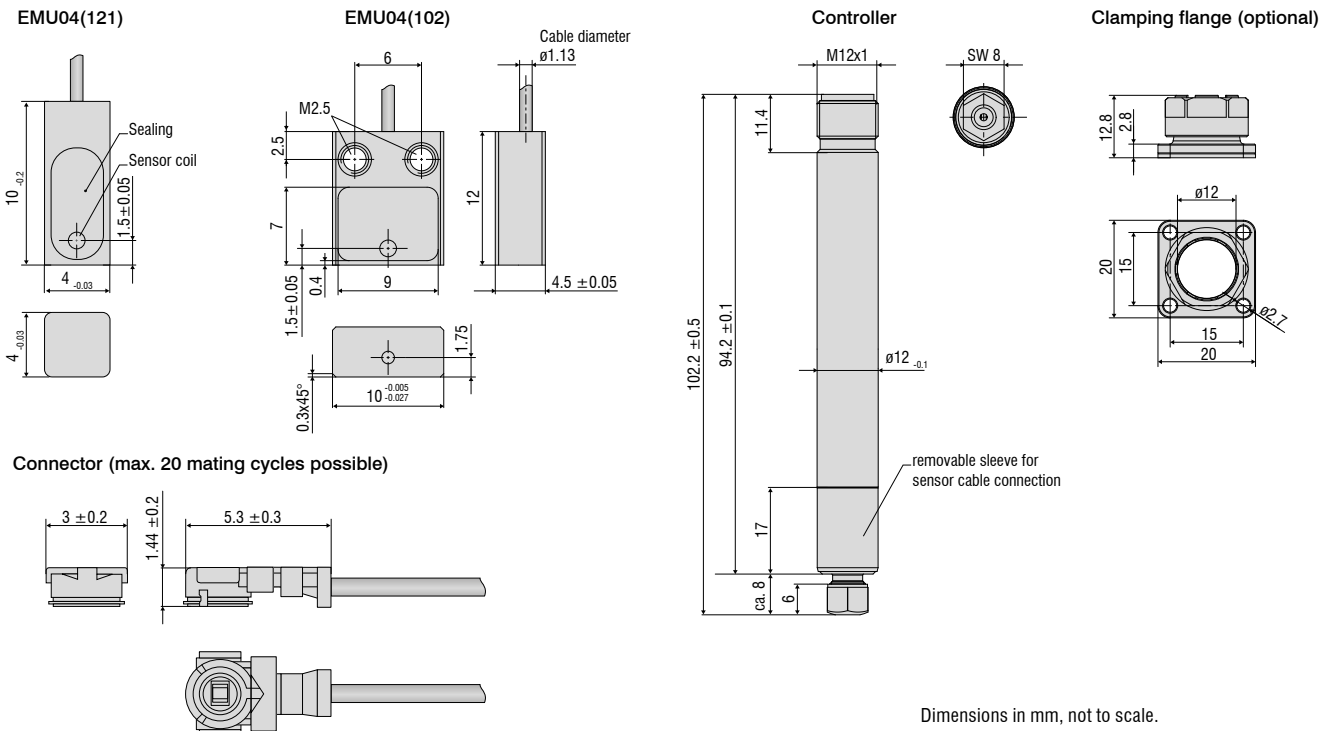

Dimensions in mm, not to scale.

Applications

eddyNCDT

Eddy current sensors from Micro-Epsilon have many possible fields of application. High measurement accuracy and increased frequency response together with an extremely robust design enable measurements where conventional sensors are not suitable.

Oil gap measurement of drive shafts

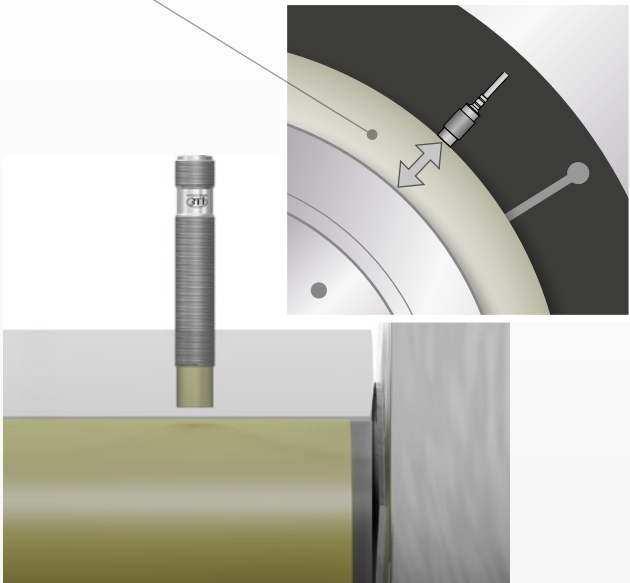

Run-out monitoring of rolls

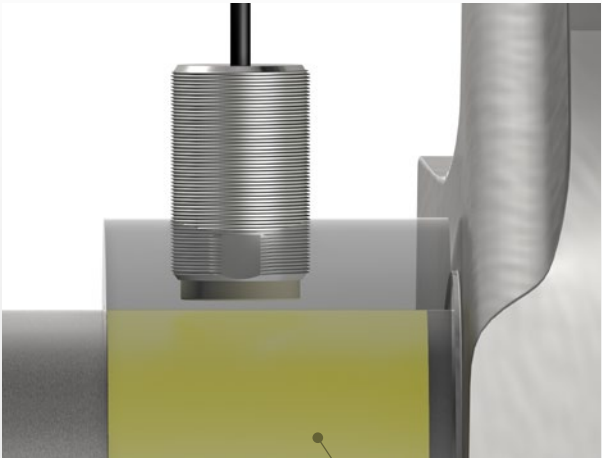

Measuring the radial shaft expansion

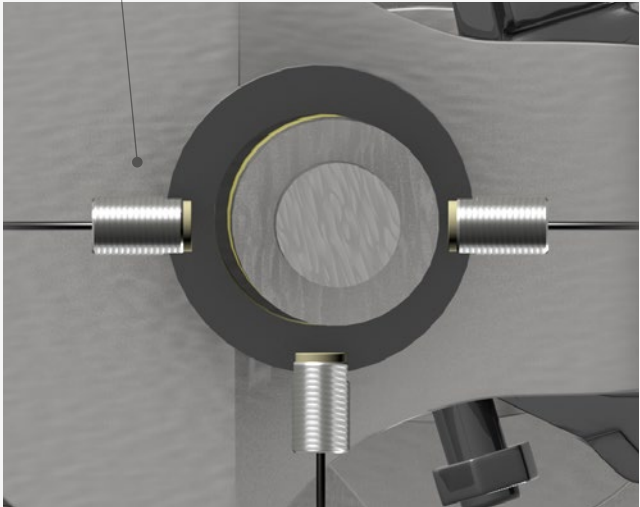

Monitoring of axial shaft displacement

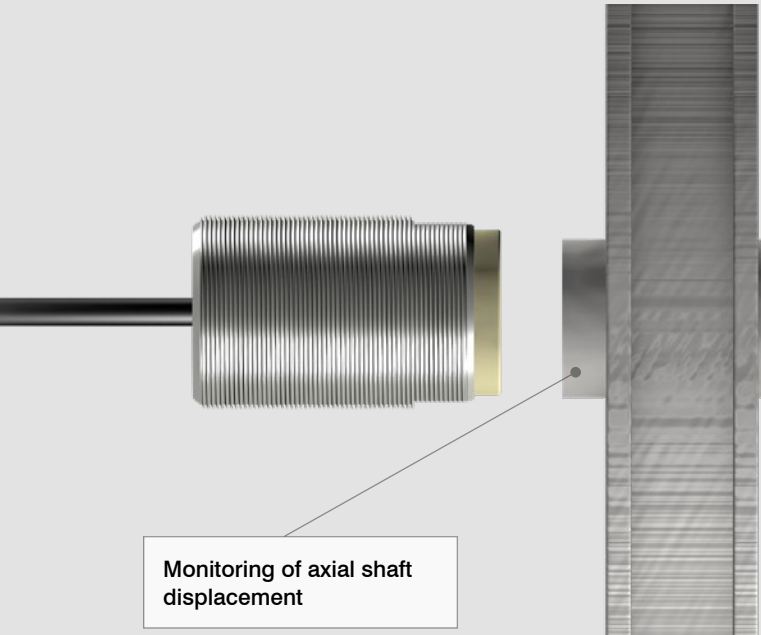

Environmental influences such as oil, temperature, pressure and moisture are largely compensated for and have a minimal effect on the signal. For this reason, the sensors are ideal in demanding application areas, such as industrial mechanical engineering and test bench construction.

Monitoring the supporting moments in wind turbines

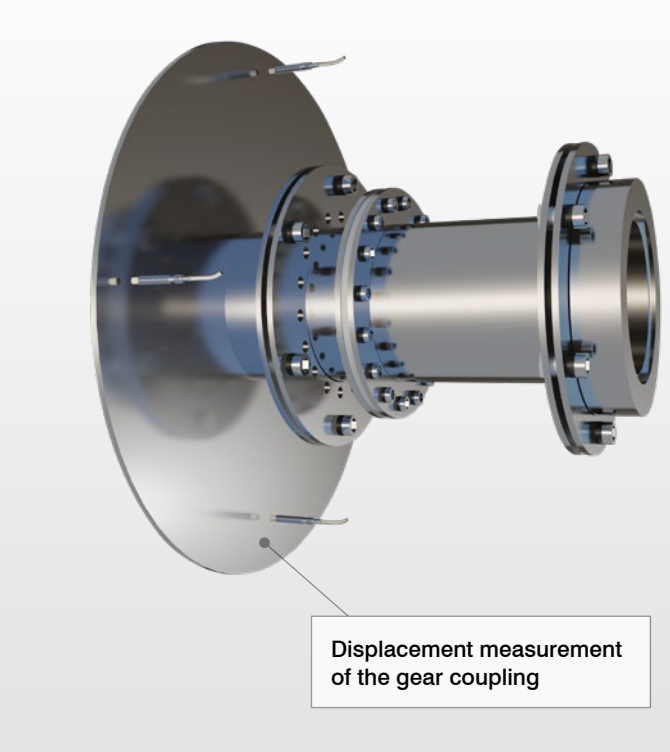
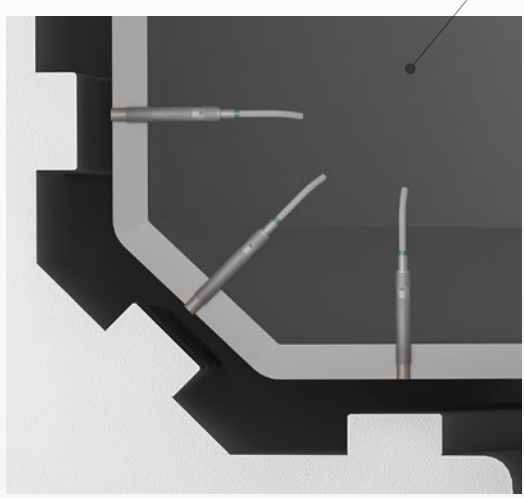

Displacement measurement of the gear coupling

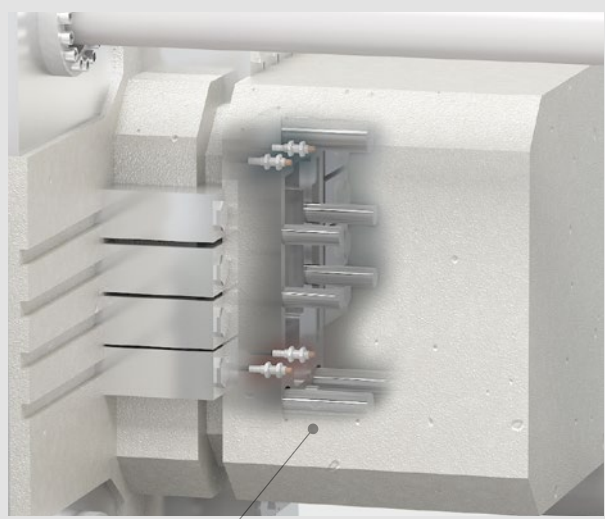

Gap measurement in aluminum die-casting molds

Run-out monitoring of gear shafts

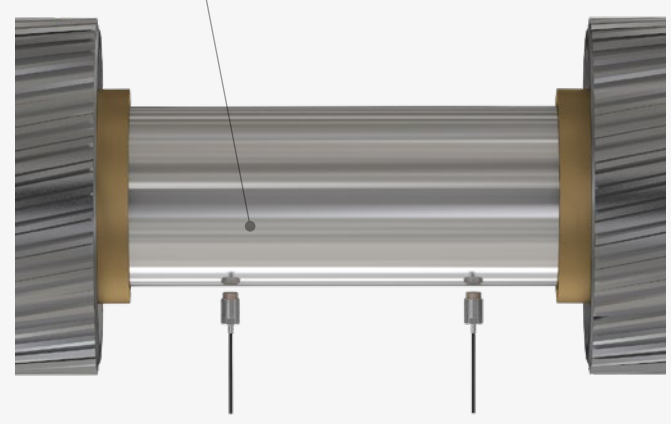

Accessories

eddyNCDT

Article	Description	DT3001	DT3005	DT3060	DT3070	DT3300	DZ140	SGS
PCx/8-M12	Supply and signal cable 8-pole with M12 connector Standard length: 3 m Optionally available: 5 m / 10 m / 15 m 10 m as drag-chain suitable variant			x	x			
PCx/5-M12	Supply and signal cable 5-pole with M12 connector Standard length: 5 m Optionally available: 10 m / 20 m / 40 m / 80 m as drag-chain suitable variant	x	x					
PC4701-x	Supply and signal cable 8-pole with M12 connector Standard length: 10 m Optionally available: 15 m 10 m as drag-chain suitable variant							x
SCD2/4/RJ45	Ethernet cable 4-pole with M12 connector on RJ45 connector Standard length: 2 m			x	x			
SCAx/5	Signal cable, analog 5-pole with M16x0.75 connector Standard length: 3 m Optionally available: 6 m / 9 m					x		
SCDx/8	Signal cable for switching inputs and outputs: 8-pole with M16x0.75 connector Standard length: 0.3 m Optionally available: 1 m					x		
PSCx	Supply and synchronization cable 5-pole with M9 connector Standard length: 0.3 m Optionally available: 1 m					x		
ESCx	Synchronization cable 5-pole with M9 connector Standard length: 0.3 m Optionally available: 1 m					x		
PC140-x	Supply and signal cable 8-pole connector Standard length: 3 m Optionally available: 6 m						x	
PS2020	Power supply unit Input 100-240 VAC output 24 VDC / 2.5 A; mounting onto symmetrical standard rail 35 mm x 7.5 mm, DIN 50022	x	x	x	x	x	x	x

Standard installation situation

Distance between the nut and the measuring area

eddyNCDT sensors are mounted using the two mounting nuts included in the delivery. During the factory-calibration of the sensors, these were mounted in a defined distance A and included in the calibration. In order to achieve maximum linearity, the nut must be mounted in the defined distance indicated in the table.

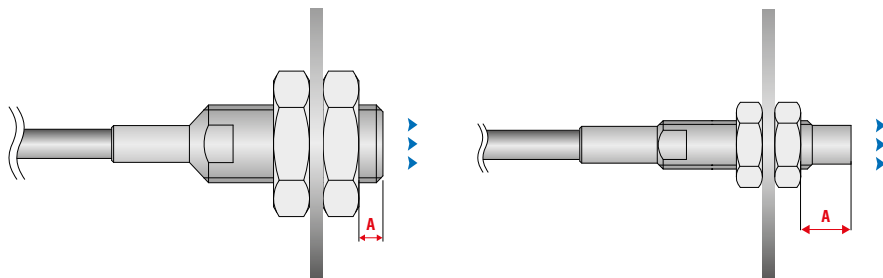

Please note the respective distances recommended in the table below when mounting the sensors:

Series	Model	Distance A
DT3001-	U2-A-SA	22 mm (±0.2 mm)
	U2-M-SA	22 mm (±0.2 mm)
	U4-A-SA	22 mm (±0.2 mm)
	U4-M-SA	22 mm (±0.2 mm)
	U4-A-Cx	22 mm (±0.2 mm)
	U4-M-Cx	22 mm (±0.2 mm)
	U6-A-SA	22 mm (±0.2 mm)
	U6-M-SA	22 mm (±0.2 mm)
	U8-A-SA	22 mm (±0.2 mm)
	U8-M-SA	22 mm (±0.2 mm)
DT3005-	U1-A-C1	8 mm (±0.2 mm)
	U1-M-C1	8 mm (±0.2 mm)
	S2-A-C1	4 mm (±0.2 mm)
	S2-M-C1	4 mm (±0.2 mm)
	U3-A-C1	10 mm (±0.2 mm)
	U3-M-C1	10 mm (±0.2 mm)
	U6-A-C1	13 mm (±0.2 mm)
	U6-M-C1	13 mm (±0.2 mm)
DT3060-	ES-U1	8 mm (±0.2 mm)
	ES-S1	4 mm (±0.2 mm)
	ES-U2	8 mm (±0.2 mm)
	ES-S2	4 mm (±0.2 mm)
	ES-U3	10 mm (±0.2 mm)
	ES-S4	4 mm (±0.2 mm)
	ES-U6	20.4 mm (±0.2 mm)
	ES-U8	24.6 mm (±0.2 mm)
DT3070-	ES-S04	2.4 mm (±0.2 mm)
DT3300-	ES04	2.1 mm (±0.2 mm)
	EU05	5.5 mm (±0.2 mm)
	ES08	2.7 mm (±0.2 mm)
	ES1	4 mm (±0.2 mm)
	EU1	6.7 mm (±0.2 mm)
	ES2	4 mm (±0.2 mm)
	EU3	10 mm (±0.2 mm)
	ES4	4 mm (±0.2 mm)
EU6	10.125 mm (±0.2 mm)	
EU8	12.8 mm (±0.2 mm)	

Influences on the measurement signal

Sensor installation

The notes mentioned under "Standard installation situation" for correct sensor installation affect the measurement signal.

Minimum diameter of the target (flat)

The relative size of the target has effects on the linearity deviation. Ideally, the target size with shielded sensors is at least 2 times the sensor diameter, with unshielded sensors it is 4 times the sensor diameter. From this size on, almost all field lines run from the sensor to the target and therefore contributing to the formation of eddy currents. With smaller target diameters, field linearization is recommended.

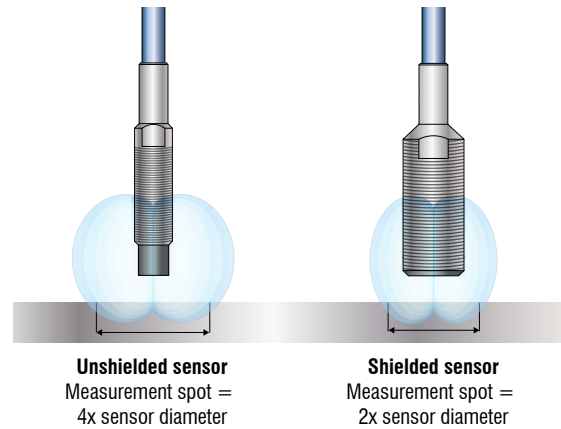

✓ **Target = 4x or 2x sensor diameter**
recommended (no linearization is required)

F **Target = 3x or 1.5x sensor diameter**
requires field linearization (DT306x / DT3300)



Minimum diameter of round targets

As well as the minimum size for flat geometries, a minimum diameter for round measurement objects is required.

F **Diameter > 10x sensor diameter**
requires field linearization (DT306x / DT3300)

W **Diameter < 10x sensor diameter**
requires factory calibration

Compensating the distance with curved measurement objects

When measuring on curved surfaces such as shafts, the sensors use the medium distance which results from the closest and the most distant field line range. However, this is not the distance between the vertex of the curved target and the sensor. For this reason, eddy current measuring systems from Micro-Epsilon enable the storage of the actual distance in the controller. This is how measurements can be performed on cylindrical objects such as rolls or shafts.

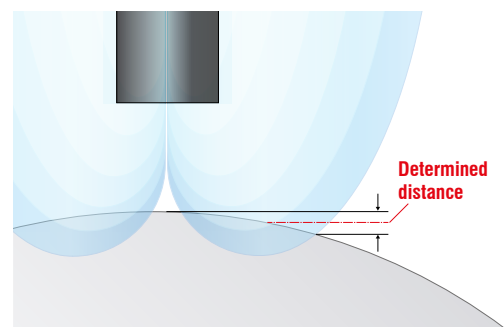

Material and thickness of the target

Stable measurement results require a certain target minimum thickness that depends on the target material used. For one-sided distance measurements, the following standard values are recommended:

Target material	Recommended target thickness
Aluminum	0.504 mm
Lead	1.377 mm
Gold	0.447 mm
Graphite	8.100 mm
Copper	0.402 mm
Magnesium	0.627 mm
Brass	0.747 mm
Nickel	0.081 mm
Permalloy	0.012 mm
Phosphor Bronze	0.906 mm
Silver	0.390 mm
Steel DIN 1.1141	0.069 mm
Steel DIN 1.4005	0.165 mm
Steel DIN 1.4301	2.544 mm

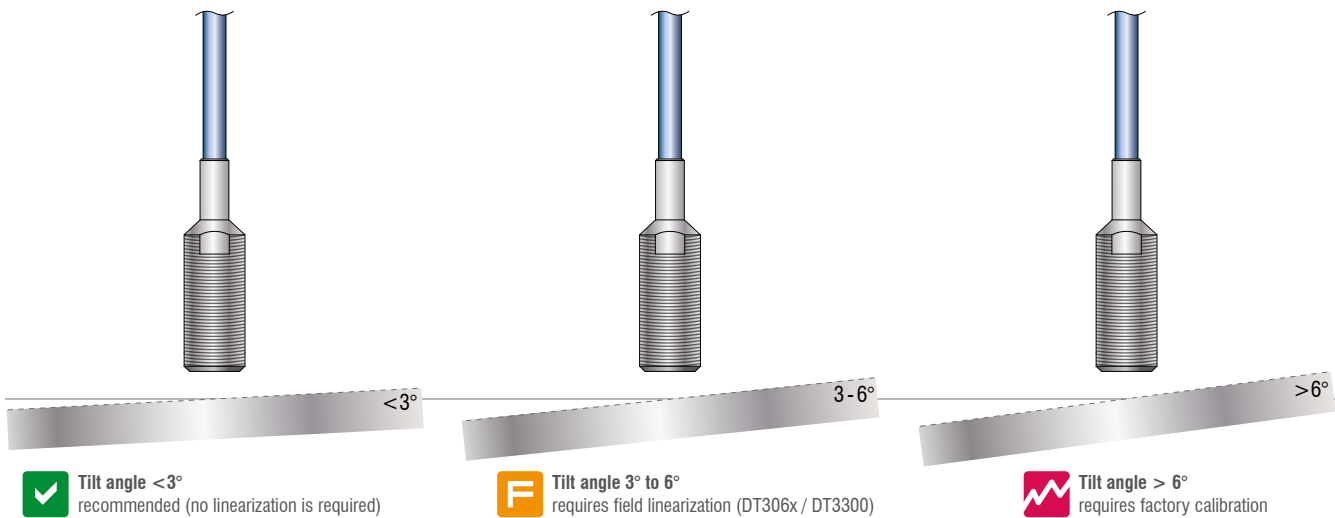

Tilt angle

The high accuracy of the eddyNCDT sensors is only achieved with vertical sensor installation. When the sensor or the target are tilted, the measured results slightly deviate from those measured in the vertical position.

The extent of deviation differs from sensor to sensor. The tilt angle of $\pm 3^\circ$ can be neglected for most of the measurement tasks. With a tilt angle of larger than 6° , factory calibration is recommended. With a 3-point calibration, the tilt angle can be stored in the controller. This compensates for all influences affecting the signal.

Frequency separation

For operating several eddyNCDT measuring systems, a new frequency separation (LF/HF) is provided. The frequency separation enables multi-channel operation without mutual influence. This function makes a synchronization cable unnecessary..

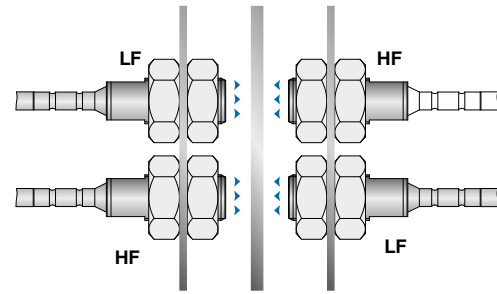

Field calibration

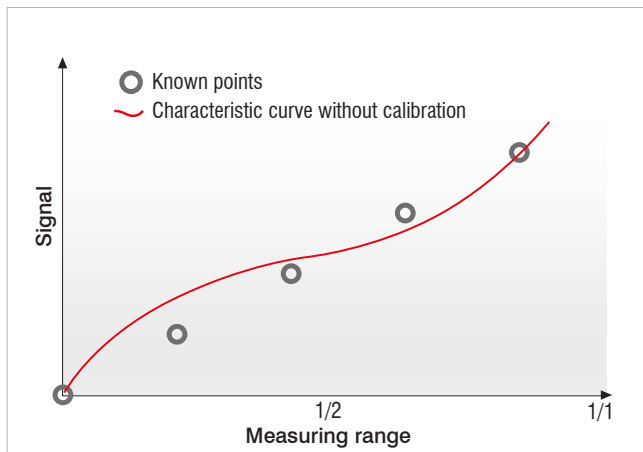

If the installation situation does not correspond to the standard installation conditions, field linearization is recommended (available with eddyNCDT 3060 and eddyNCDT 3300) This on-site calibration compensates for influences which result from the installation scenario or the target materials and shapes. Therefore, optimum measurement accuracies will always be achieved even in the case of difficult installation conditions.

For machine integration, linearization with 2 fixed points (start and end point) is sufficient in most cases. Using 3 or 5 points for linearization enables to increase the accuracy again.

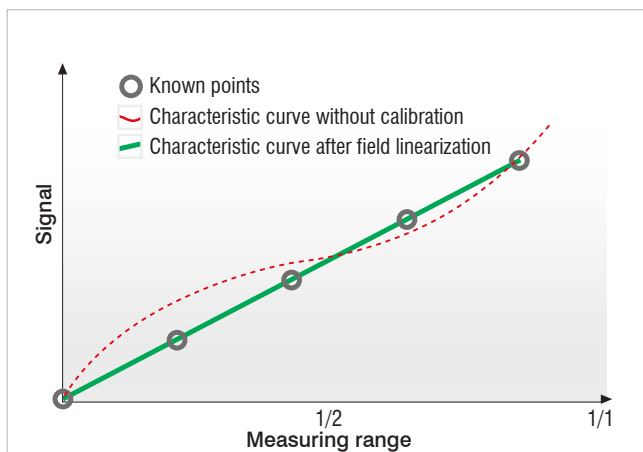

For a linearization with 2 or more points, this applies only within the selected edge points. Outside this range, there may be larger linearity deviations.

Thermal drift of a Micro-Epsilon eddy current system compared with the competitors

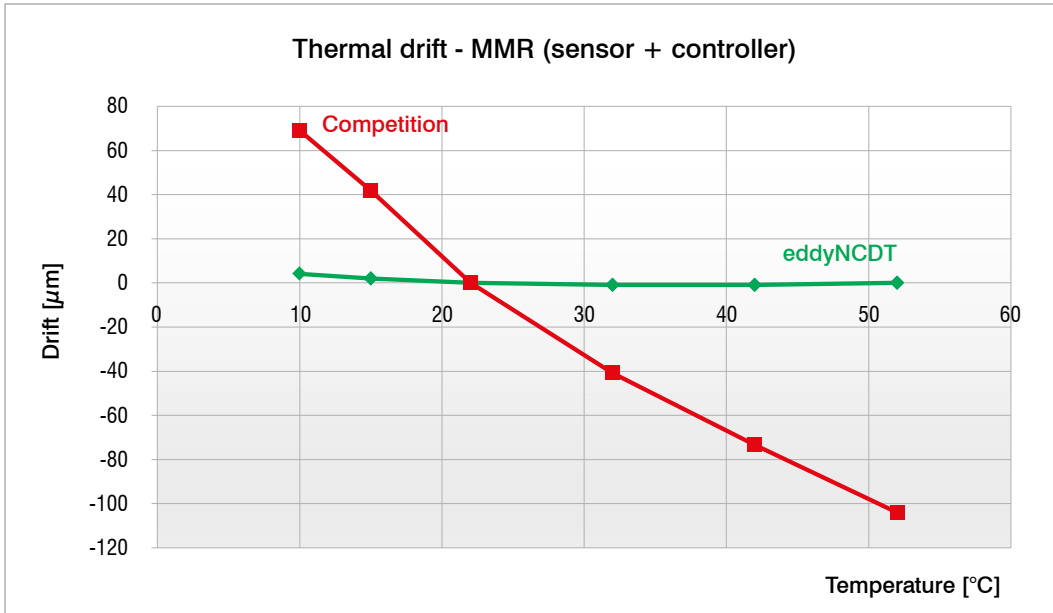

All eddyNCDT sensors and controllers are actively temperature-compensated (sensors up to max. 180 °C, controllers up to max. 50 °C). This means that the temperatures of the sensor and the controller are recorded during operation and considered in the measurement result. Consequently, you get an extremely stable measurement signal.

The temperature curve above compares a Micro-Epsilon sensor (green) with a competitive product (red). The maximum deviation over the entire temperature range is significantly below the 150 ppm/°C specified in the data sheet. Occasionally the deviation for the temperature increase of one degree amounts to a maximum of 150 ppm.

Conclusion: In order to keep precise measurement values in the μm range constant and reliable, the resolution to be achieved and the temperature influence are crucial factors. The temperature stability of the Micro-Epsilon system achieves such a high level that temperature fluctuations are actively compensated for. Due to the higher temperature influence of the competitor system, even daily temperature fluctuations of ± 2.5 °C can cause a deviation of >20 μm . Measurements with micrometer accuracy are therefore not possible with the competitor system without active temperature compensation, even in normal environments.

Sensors and Systems from Micro-Epsilon



Sensors and systems for displacement, distance and position



Sensors and measurement devices for non-contact temperature measurement



Measuring and inspection systems for metal strips, plastics and rubber



Optical micrometers and fiber optics, measuring and test amplifiers



Color recognition sensors, LED analyzers and inline color spectrometers



3D measurement technology for dimensional testing and surface inspection