



More Precision

colorCONTROL ACS7000 // Inline Photospectrometer





- *Inline color measurement:
25Hz – 2,000Hz*
- *Measurement without touching
the sample*
- *Measurement precision $\Delta E \leq 0.08$*
- *Inline color measurement:
25Hz – 2,000Hz*
- *Ethernet/EtherCAT, RS 422, digital I/O*
- *Web browser operation*

- ▶ Light source: Adjustable “standard illuminant” and “standard observers”
- ▶ Color space: XYZ; L*a*b*; L* u* v*; L*c*h°; adjustable
- ▶ Color recognition from a taught reference list
- ▶ White/black reference comparison (via browser and buttons on the device)
- ▶ Inline quality assurance and continuous monitoring
- ▶ Options: measuring head geometries for different technical surfaces

The colorCONTROL ACS7000 inline color measurement system not only recognises reference colors by comparison, but identifies individual colors clearly from their coordinates in the color space. With its very high measurement speeds, the colorCONTROL ACS7000 is suitable for applications where colors and shades have to be examined on-the-fly and to very high accuracies. Because of its high measurement accuracy, the system is also used in laboratory tasks.

Measuring principle

The spectral procedure is the most accurate method of color measurement. First, the sample is illuminated with a homogeneous white LED light. The spectrum of the reflected light is then calculated with a white reference. Then the coordinates in the CIE-XYZ color

system are determined for all wavelengths of visible light (390 to 780nm) and output in the desired color space. The controller takes into account different observation conditions such as the type of light (illuminant) and standard observer.

Function

Three operating modes are possible with the colorCONTROL ACS7000: In the first mode, the color distance ΔE is measured for reference. The system operates with up to 15 taught values. In the second mode, the reflectivity spectrum of the sample is determined and output. In the third mode, color coordinates are determined and displayed in the desired color space. For quality inspection purposes, a trend analysis can be carried out over any time period via the L*a*b*; XYZ or L*c*h° co-

lor values. Measurements can be performed in all modes at speeds of up to 2kHz. Operation and display is via a Web interface. Light/dark correction can also be carried out using buttons on the controller or the user interface. Ethernet/ EtherCAT, RS422 and digital I/Os are available for data output.

Controller colorCONTROL ACS7000	
Article number	11104174
Spectral measuring range	390 - 780 nm
Measuring range reflectivity	0 - 200 %R
Output values	L*a*b*, L*u*v*, L*c*h°, XYZ, ΔE, spectrum
Illuminant	A, C, D65, D50, D75, E, F4, F7, F11, Off
Standard observer	2°, 10°
Distance models for color recognition	Sphere (ΔE), cylinder (ΔL*, Δa*b*), box (ΔL*, Δa*, Δb*), with individual tolerance parameters for every color taugt
Color resolution	0.01 ΔE
Spectral resolution	5nm
Measuring frequency	25 - 2,000Hz (internal spectrum, signal averaging and data reduction are possible)
Temperature stability	<0.1 ΔE/°C
Light source	LED, 390 - 780nm
Reproducibility of the measurements of a device ¹⁾	<0.03 (mean); <0.08 (max) ΔE
Housing dimensions	210x120x90mm (WxHxD)
Weight	1.8kg
Protection class	IP40
Operating temperature	0°C to 45°C
Storage temperature	-20°C to 70°C
Inputs / Outputs	Four color detection switching outputs (4 individual colors or 15 colors binary or {ΔE, ΔL* Δa*, Δb*} for one color) 1 Switching output, synchronisation 1 Switching input, synchronisation 1 Switching output, measurement error
Interfaces	Ethernet/EtherCAT (DHCP-enabled) RS422 (USB via RS422 adapter is possible)
Connection for fiber optics	Illumination: 7mm ferrule with M18 cap (union) nut (analogous to MICRO-EPSILON Eltrotec Fasop system) Measuring: DIN fiber connector
Connection cables	To power supply: Art. No. 11234222 / to PLC: Art. No. 11234223 / to synchronisation: Art. No. 11234091 / to PC: Art. No. 11294232 (Ethernet/EtherCAT); 11234224 or 11234230 (RS422)
Additional data processing	Internal calculation of spectral characteristics, color valence calculations, color space transformations, ΔE calculations, and tolerance settings of the upper and lower thresholds for the color values
Connection to software	Control and configuration via integrated Web server or via terminal with commands Visualisation of spectral characteristics and temporal sequence of the color values and color differences
Power supply	24VDC +/- 15% 1000mA
Service life of the light source	>20,000h when operated at 25°C

¹⁾ Medium or maximum color distance ΔE of 1000 successive measurements of the color value (mean) of a light grey reference tile (R = 61%), measured with sensor FCS-T-ACS1-30/0-50-1200 at 200Hz and maximum illumination brightness

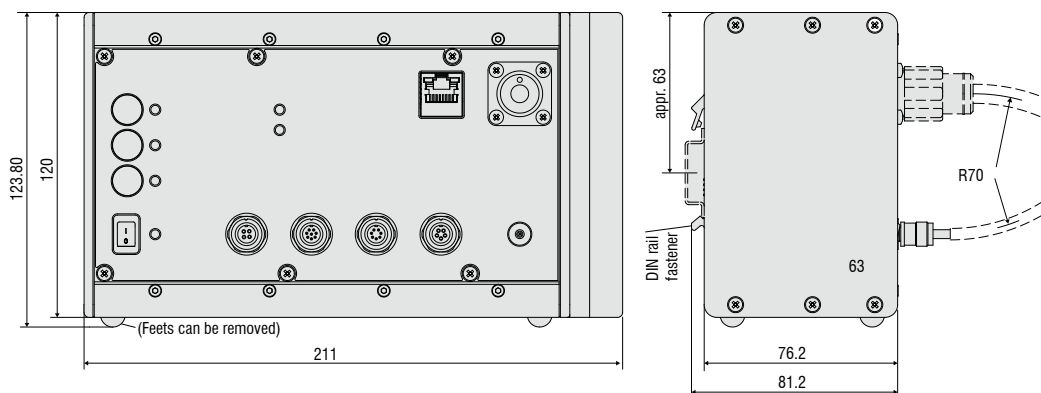



- For common measuring tasks
- Measurement distance: 38 or 50 mm
- Measurement geometry: $45^\circ \times 0^\circ$; $30^\circ \times 0^\circ$
- Measurement spot: $\varnothing 9\text{mm}$

The standard sensor ACS1 is used for common measuring tasks. The transmitter and the receiver inside the sensor are arranged at an angle of $45^\circ \times 0^\circ$ or $30^\circ \times 0^\circ$ to each other, producing a working distance of 38mm or 50mm.

An optionally available adapter permits applying the $30^\circ \times 0^\circ$ sensor even in tactile measurements.

FCS-ACS1-30/0 adapter tactile

Article number 10824338

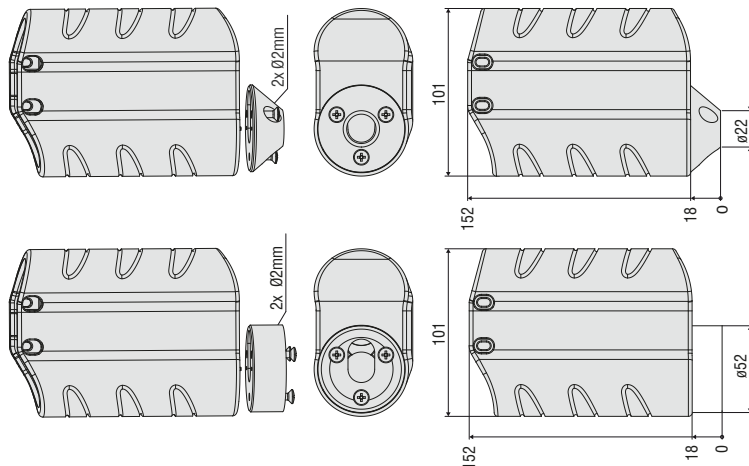

Measurement geometry:

Angular sensor model: $45^\circ \times 0^\circ$; $30^\circ \times 0^\circ$

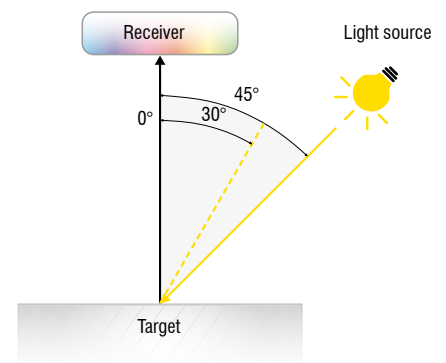

Fiber-optic sensor FCS-T	ACS1-30/0-50-1200	ACS1-45/0-38-1200
Article number	10824175	10824371
Geometry (illumination : receiver)	30°x:0°	45°x:0°
Measuring spot diameter	9mm	9mm
Optimal measurement distance	50mm	38mm
Working range	±2mm of optimal working distance ($\Delta E < 1$)	±1mm of optimal working distance ($\Delta E < 1$)
Distance tolerance	0.5 ΔE /mm	1 ΔE /mm
Tilt angular tolerance	<0.3 ΔE /°	<1.33 ΔE /°
Ambient light tolerance at max. LED-performance ¹⁾	<0.5 ΔE / 1000lux	<0.6 ΔE / 1000lux
Dimensions	85x120x40mm	106x125x40mm
Weight (sensor incl. optical fiber)	420g	500g
Length of the optical fiber/sensor cable (optical-fiber cable)	1.2m (max 1.8m)	1.2m (max 1.8m)
Bending radius sensor cable	70mm	70mm
Protection class	IP64	IP64
Operating temperature	-20°C ... +50°C	-20°C ... +50°C
Storage temperature	-20°C ... +50°C	-20°C ... +50°C
Shock resistance	DIN EN 60068-2-29; 15g, 6ms	DIN EN 60068-2-29; 15g, 6ms
Vibration resistance	DIN EN 60068-2-6; 2g / 10Hz...500Hz	DIN EN 60068-2-6; 2g / 10Hz...500Hz

¹⁾ Measured at maximum illumination for reference tile (R = 61%) light grey with warm white external LED light source

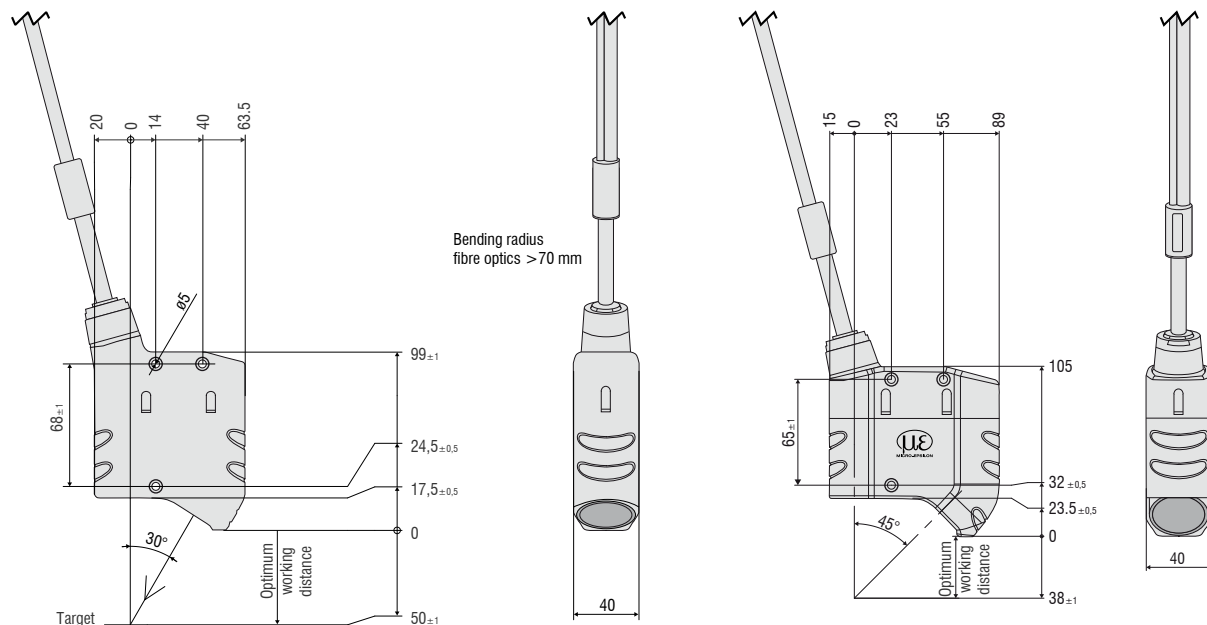



- Color measurement of structured, highly reflective surfaces and lustrous metals
- Measurement distance: 28mm / 27.5mm
- Measurement geometry:
Circular sensor 45°c:0°
- Measurement spot: $\varnothing 5\text{mm} / 3 \times 2\text{mm}$

The circular sensor ACS2 is used for color measurement of structured and highly reflective surfaces as well as lustrous metals.

In the sensor, 24 lighting optics are circularly arranged around the receiving optics and provide a constant homogeneous lighting permitting that the measurement can be executed independently from the angular position of the measurement object.

This sensor enables as well to measure small measurement objects and curved surfaces.

Measurement geometry:

Circular sensor 45°c:0°

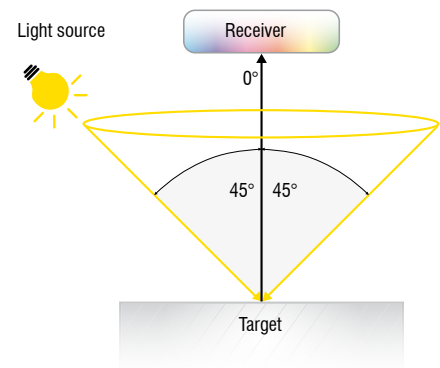

Fiber-optic sensor FCS-T	ACS2-R45/0-28-1200	ACS2-R45/0-28-1200(001)
Article number	10824370	10824370.001
Measurement geometry (illumination : receiver)	45°c:0° (circular)	45°c:0° (circular)
Measurement spot diameter	5mm (optional 9mm)	3 x 2mm
Optimal measurement distance	28mm	27.5mm
Permissible measurement distance	±1mm of optimal measurement distance ($\Delta E < 1$)	+1.5mm / -0.7mm
Distance tolerance	1 ΔE /mm	1 ΔE /mm
Tilt angular tolerance	<0.3 ΔE /°	<0.3 ΔE /°
Ambient light tolerance at max. LED-performance	<0.3 ΔE /1000lux	<0.3 ΔE /1000lux
Dimensions	Ø115x65mm	Ø115x65mm
Weight (sensor incl. optical fiber)	822g	822g
Length of the optical fiber/sensor cable (optical-fiber cable)	1.2m (max 1.8m)	1.2m (max 1.8m)
Bending radius sensor cable	70mm	70mm
Protection class	IP64	IP64
Operating temperature	-20 °C ... +50 °C	-20 °C ... +50 °C
Storage temperature	-20 °C ... +50 °C	-20 °C ... +50 °C
Shock resistance	DIN EN 60068-2-29; 15g, 6ms	DIN EN 60068-2-29; 15g, 6ms
Vibration resistance	DIN EN 60068-2-6; 2g / 10Hz...500Hz	DIN EN 60068-2-6; 2g / 10Hz...500Hz

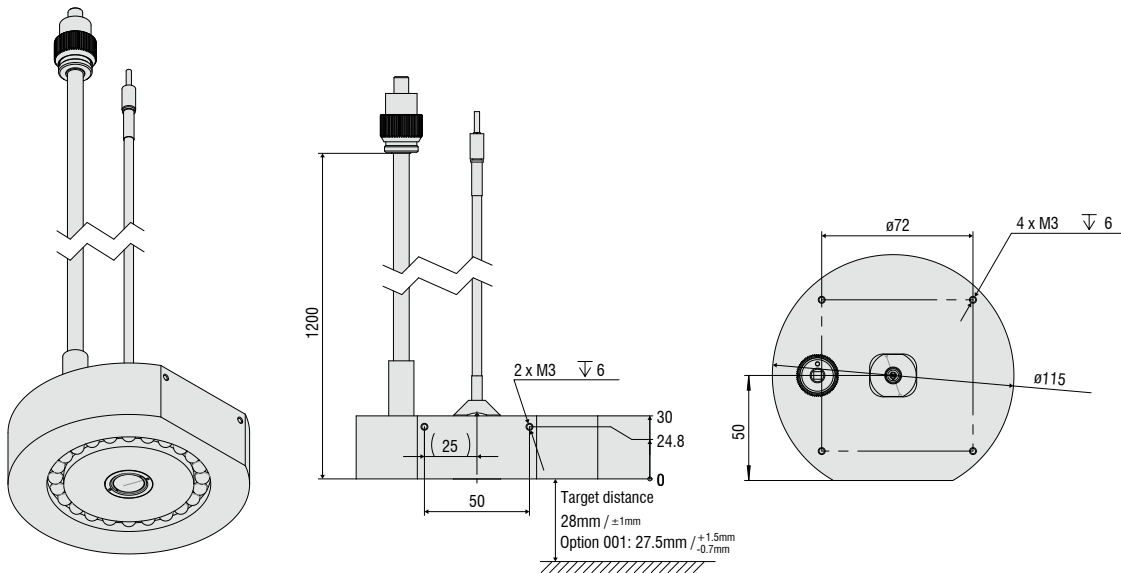

ACS2-R45/0-28-1200(001)

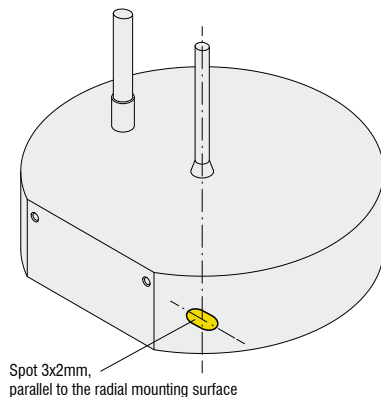
Spot 3x2mm,
parallel to the radial mounting surface

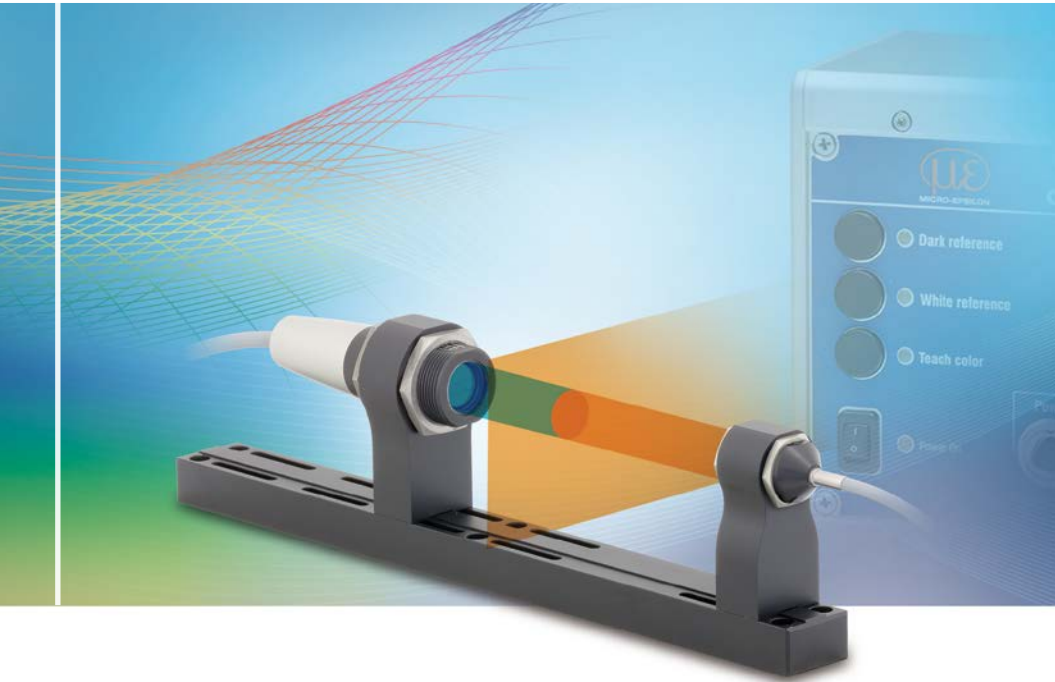

- Measurement of self-luminous and transparent objects
- Measurement distance: max 300mm
- Measurement geometry: transmission
- Measurement spot: $\varnothing 5 / \varnothing 9\text{mm}$ (at a measurement distance up to 200mm)

The transmission sensor ACS3 is used to measure self-luminous and transparent objects like foil, glass and Plexiglas. For the color measurement of self-luminous objects, only a receiver unit is required. Measuring transparent objects requires transmitter (TT) and receiver unit (TR) which can be installed with a mounting set.

Measurement geometry:
Transmission

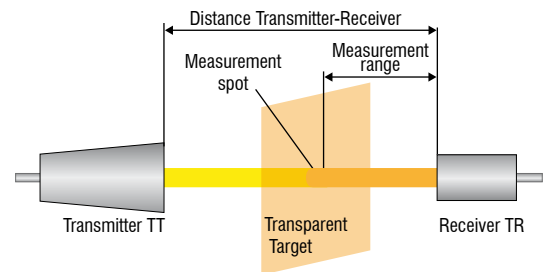

Transmission sensor with transmitter (TT) and receiver (TR) 0°:180°

FCS-ACS3-200 mounting rail

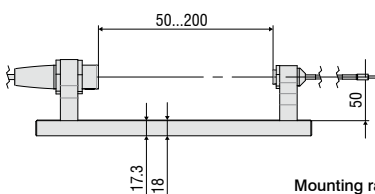
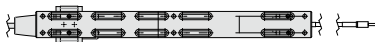

Mounting rail
Art.-No. 10824414

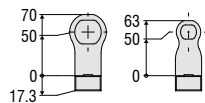

FCS-ACS3 mounting adapter 50mm
Art.-No. 10824423

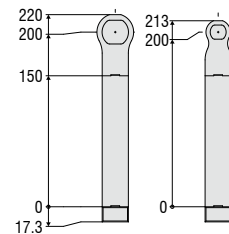
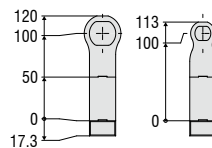

FCS-ACS3 mounting adapter 150mm
Art.-No. 10824422

Fiber-optic sensor FCS-T	ACS3-TR5-200-1200	ACS3-TR9-200-1200	ACS3-TT15-200-1200
Article number	10824411	10824412	10824413
Measurement geometry (illumination : receiver)	Receiver	Receiver	Transmitter
Measurement spot diameter	5mm for <100mm ¹⁾	9 mm for <200mm ¹⁾	15mm for 200mm ⁵⁾
Optimal measurement distance	10 ... 100mm ^{2) 3)}	10 ... 200mm ^{2) 3)}	10 ... 200mm
Working range	10 ... 200mm ^{2) 3)}	10 ... 300mm ^{2) 3)}	10 ... 300mm
Distance tolerance ⁴⁾	<0.01 $\Delta E/mm$ ⁶⁾ <0.005 $\Delta E/mm$ ²⁾	<0.01 $\Delta E/mm$ ⁶⁾ <0.005 $\Delta E/mm$ ²⁾	-
Tilt angular tolerance ⁴⁾	<0.05 $\Delta E/^\circ$	<0.05 $\Delta E/^\circ$	-
Ambient light tolerance at max. LED-performance	<0.05 $\Delta E/1000lux$	<0.05 $\Delta E/1000lux$	-
Dimensions	Ø22x40mm	Ø22x40mm	Ø30x96mm
Weight (sensor incl. optical fiber)	70g	70g	220g
Length of the optical fiber/sensor cable (optical-fiber cable)	1.2m (max. 30m)	1.2m (max. 30m)	1.2m (max. 1.8m)
Bending radius sensor cable	70mm	70mm	70mm
Protection class	IP 64	IP 64	IP 64
Operating temperature	-20°C ... +50°C	-20°C ... +50°C	-20°C ... +50°C
Storage temperature	-20°C ... +50°C	-20°C ... +50°C	-20°C ... +50°C
Shock resistance	DIN EN 60068-2-29; 15g, 6ms		
Vibration resistance	DIN EN 60068-2-6; 2g / 10Hz...500Hz		

¹⁾ Measurement spot diverges with growing distance between receiver and target

²⁾ Valid in combination with ACS3-TT15-200 for the transmission measurement (transmitted light)

³⁾ When measuring the transmission, the "optimal measurement distance" and the "working range" refer to the distance between transmitter and receiver. The sample can be at any position within the light curtain between transmitter and receiver.

⁴⁾ Tilt angular tolerance and distance tolerance were determined in transmission with different color glass filters (thickness 2.5 mm, refraction index 1.5).

When measuring the illumination (only receiver), these were determined with uniformly illuminated (Lambertian) diffuser by tilting the transmitter towards the receiver.

⁵⁾ Illumination spot diameter

⁶⁾ When using it as receiver sensor for illumination measurement

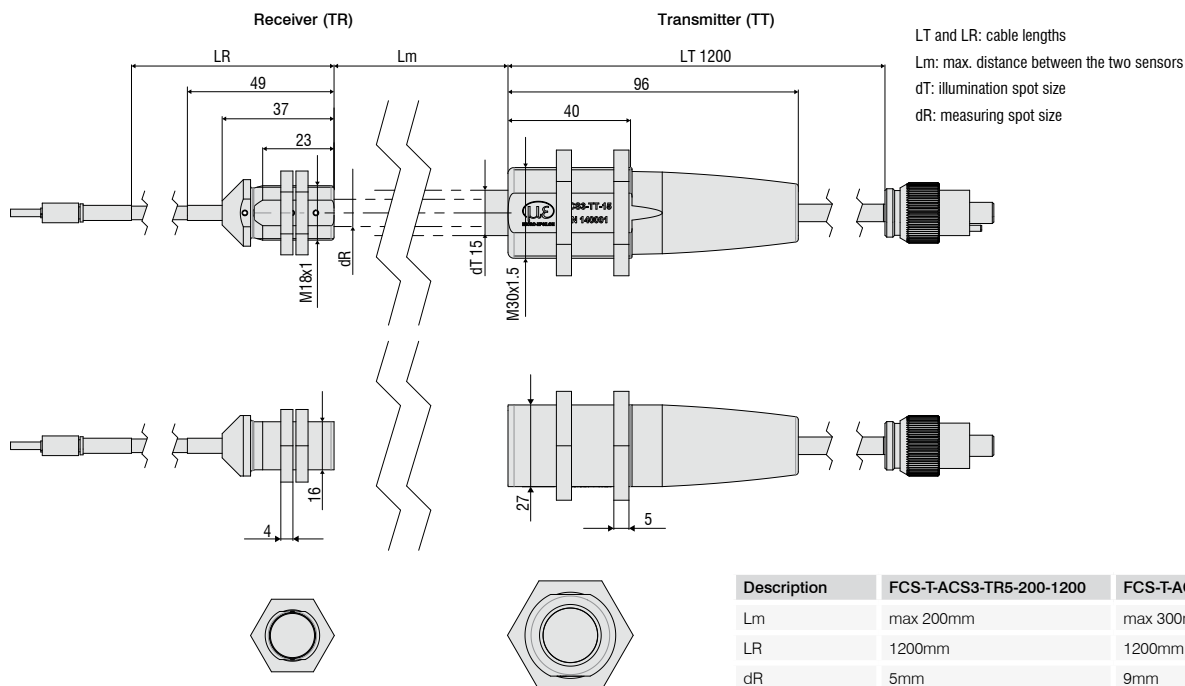

Spectrum and color coordinate in the user interface

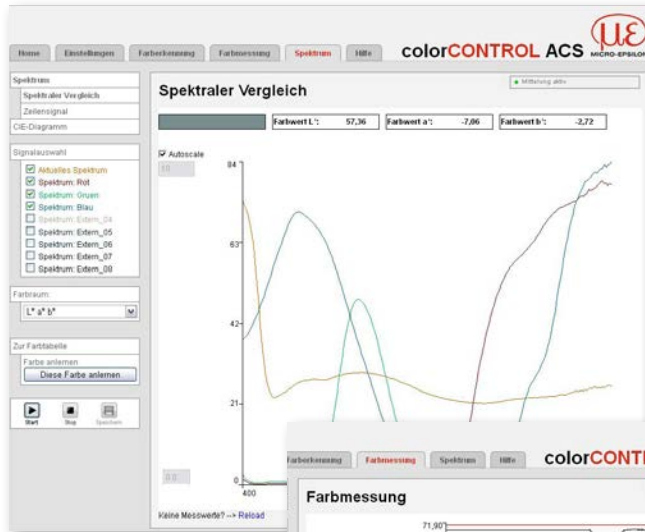

Depiction of color values in the color space

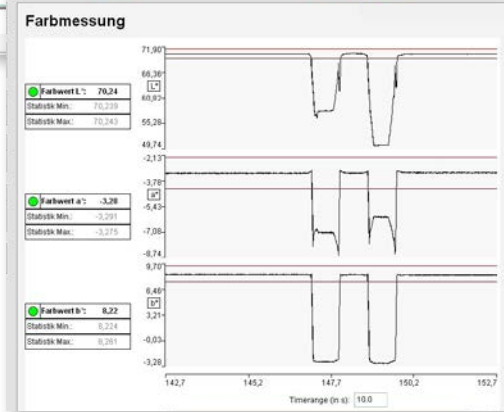
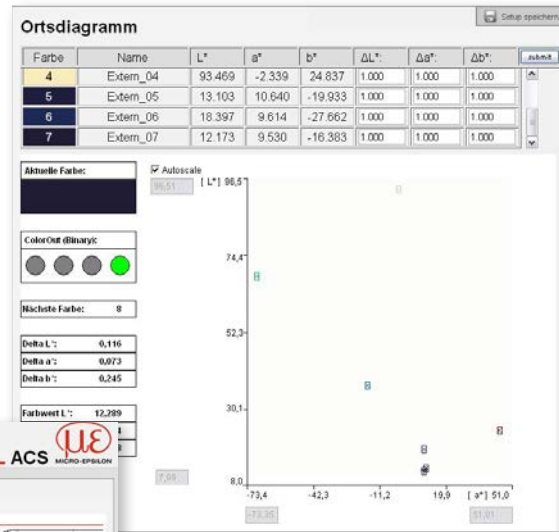

Measurements of XYZ, L*a*b*, L*u*v*, L*c*h° shown over time

Applications:

- Inline measurement in production lines, all industries: Plastics, wood, paper, film and foil, injection moulding, textiles and pharmaceuticals
- Interior color measurement
- Inspection of car paint

Benefits:

- Continuous process measurement to ensure consistent product quality
- Direct feedback to the production process is possible
- Lower production costs
- Minimisation of waste and rejects



Inline measurement of the color gradient of glass, Plexiglas, PET and PVC foils, paper.



Measurement of the zinc sheet color.



Interior and attachment parts in the automotive industry.

colorCONTROL ACS accessories

Art. no.	Description	suitable for:
11234274	Reflectance standard 30mm Zenith	colorSENSOR and colorCONTROL
11234695	Reflectance standard 30mm Zenith	colorSENSOR and colorCONTROL
11234696	Reflectance standard 5x5cm Zenith	colorSENSOR and colorCONTROL
11234697	Reflectance standard 5x5cm Zenith calibrated	colorSENSOR and colorCONTROL
11234222	CAB-M9-4P-co-straight; 2m-PUR; open ends	colorCONTROL ACS7000 (power)
11234225	CAB-M9-4P-co-straight; 5m-PUR; open ends	colorCONTROL ACS7000 (power)
11234091	CAB-M9-8P-co-straight; 2m-PUR; open ends	colorCONTROL ACS7000 (digital I/O, Sync.)
11234099	CAB-M9-8P-co-straight; 5m-PUR; open ends	colorCONTROL ACS7000 (digital I/O, Sync.)
11234223	CAB-M9-7P-co-straight; 2m-PUR; open ends	colorCONTROL ACS7000 (color Out)
11234226	CAB-M9-7P-co-straight; 5m-PUR; open ends	colorCONTROL ACS7000 (color Out)
11294232	CAB-RJ45-Eth; 2m-PVC-Cat5e; RJ45-Eth	colorCONTROL ACS7000 (Ether-net/-CAT)
11293257	CAB-RJ45-Eth; 5m-PVC-Cat5e; RJ45-Eth	colorCONTROL ACS7000 (Ether-net/-CAT)
11294277	CAB-RJ45-Eth-Cross; 3m-PVC-Cat5e; RJ45-Eth	colorCONTROL ACS7000 (Ether-net/-CAT)
11293258	CAB-RJ45-Eth-Cross; 5m-PVC-Cat5e; RJ45-Eth	colorCONTROL ACS7000 (Ether-net/-CAT)
11234224	CAB-M9-5P-co-straight; 2m-PVC-RS422; open ends	colorCONTROL ACS7000 (RS422)
11234227	CAB-M9-5P-co-straight; 5m-PVC-RS422; open ends	colorCONTROL ACS7000 (RS422)
11234230	CAB-M9-5P-co-straight; 2m-PVC-RS422; Sub-D-15P-co-straight	colorCONTROL ACS7000 (IF2008)
11234231	CAB-M9-5P-co-straight; 5m-PVC-RS422; Sub-D-15P-co-straight	colorCONTROL ACS7000 (IF2008)
2213017	IF2008 Interface card RS422 / PCI-card	colorCONTROL ACS7000 (RS422/PC)
2213025	IF2001/USB single channel RS422/USB converter	colorCONTROL ACS7000
10824338	FCS-ACS1-30/0 adapter tactile	FCS-X-ACS1-30/0-50-XXXX
10824424	FCS-ACS adapter TT-TR	all ACS sensor heads (connection illumination into receiving fibers)
10824414	FCS-ACS3-200 mounting rail	FCS-X-ACS3
10824423	FCS-ACS3 mounting adapter 50mm	FCS-ACS3-200 mounting rail
10824422	FCS-ACS3 mounting adapter 150mm	FCS-ACS3-200 mounting rail
10824708	FCS-ACS1/ILD1420 mounting adapter angled	FCS-X-ACS1 for distance measurement with ILD1420
10824709	FCS-ACS2/ILD1420 mounting adapter angled	FCS-X-ACS2 for distance measurement with ILD1420
10824710	FCS-ACS2/ILD1420 mounting adapter straight	FCS-X-ACS2 for distance measurement with ILD1420
2420065	PS2030 power supply 24V/24W/ 1A; 2m-PVC; terminal-2P-co-fm-straight	CAB-M9-4P-co-straight; Xm-PUR; open ends (Power)

Pin assignment

CAB-M9-5P-co-straight; Xm-PVC-RS422; open ends
 (Art. no.: 11234224; 11234227)
 Connection cable RS422
 (max. length 5m, sheath PVC)

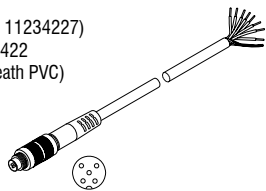

Pin	Color	ACS7000	15 PIN IF2008	10 PIN IF2001
1	white	TX	3	3
2	brown	/TX	4	4
3	green	/RX	2	2
4	yellow	RX	1	1
5	grey	GND RS422 DC-isolated	15	9

CAB-M9-8P-co-straight; Xm-PUR; open ends
 (Art. no.: 11234091; 11234098)
 Connection cable to power/PLC or digital I/O
 (max. length. 10m, sheath PUR)

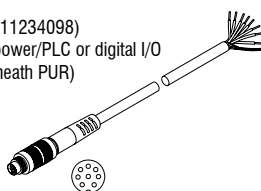

Pin	Color	ACS7000
1	white	Error
2	brown	GND Error
3	green	Sync. OUT
4	yellow	GND Sync. OUT
5	grey	Sync. IN
6	pink	GND Sync. IN
7	blue	LLL/HLL
8	red	LLL/HLL

CAB-M9-7P-co-straight; Xm-PUR; open ends
 (Art. no.: 11234223; 11234226)
 Connection cable color OUT
 (max. length 10m, sheath PUR)

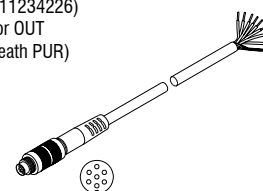

Pin	Color	ACS7000
1	white	OUT 0
2	brown	OUT 1
3	green	OUT 2
4	yellow	OUT 3
5	grey	GND
6	pink	n.c.
7	blue	n.c.

CAB-M9-4P-co-straight; Xm-PUR; open ends
 (Art. no.: 11234222; 11234225)
 Connection cable to power
 (max. length. 10m, sheath PUR)

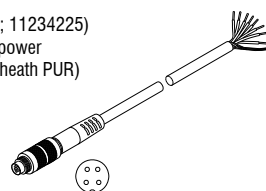

Pin	Color	ACS7000
1	white	n.c.
2	brown	+24V DC (±15%)
3	black	n.c.
4	blue	GND (0V)

High performance sensors made by Micro-Epsilon



Sensors and systems for displacement and position



Sensors and measurement devices for non-contact temperature measurement



2D/3D profile sensors (laser scanner)



Optical micrometers, fiber optic sensors and fiber optics



Color recognition sensors, LED analyzers and color online spectrometer



Measurement and inspection systems