

T001 // Precise non-contact displacement sensors



Contents:

- Introduction
- Inductive sensors based on eddy currents
- Capacitive sensors
- Laser triangulation sensors
- Confocal sensors
- Comparison of all principles

Introduction

Non-contact displacement sensors increasingly contribute to the solution of demanding measurement tasks and are used for applications where high-sensitive surfaces not allow any contact and sensors have to operate wear-free. As well as capacitive and confocal sensors, eddy current technology and laser triangulation sensors have also proved themselves in numerous applications. Non-contact sensors are available in many different versions. However, if these sensors should provide high precision results, the range decreases significantly.

In order to classify sensors in the high precision range, Micro-Epsilon has evolved the following conditions:

Linearity	< 0.2 % FSO
Resolution	< 0.005 % FSO
Measuring rate	more than 5kHz
Temperature stability	< 0.05 % FSO/K

FSO = Full Scale Output

As specialist in non-contact displacement measurement, Micro-Epsilon offers a variety of high precision sensor technologies. Despite this restriction, there are still numerous products on the market from which the appropriate sensor for a certain application has to be chosen. This TechNote explains the functioning of the individual principles and simplifies the selection from different principles.

Please note that not only the sensor itself is responsible for the achieved precision but rather the combination of highly precise electronics, signal processing and the sensor.

Eddy current sensors



Capacitive sensors



Laser Displacement Sensors



Confocal sensors



Eddy current measuring principle

Strictly speaking, the eddy current principle should be classified as the inductive measuring principle. Measuring via eddy current is based on the extraction of energy from an oscillating circuit. This energy is needed for the induction of eddy currents in electrically-conductive materials. Here, a coil is supplied with an alternating current, causing a magnetic field to form around the coil. According to Faraday's Law of induction, if an electrically-conducting object is present in this magnetic field, eddy currents are produced in it.

According to the Lenz Rule, the field of these eddy currents is opposed to the field of the coil, which causes a change in the coil impedance. This impedance change depends on the distance and can be captured as change in the amplitude of the sensor coil as a measurable factor at the controller.

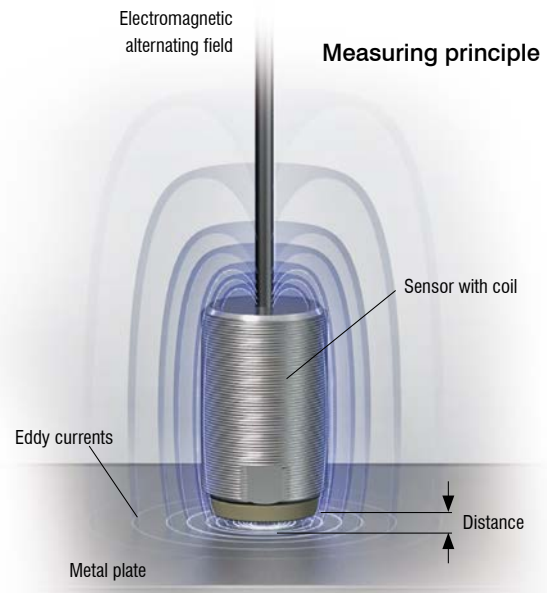

Advantages of eddy current sensors:

- Useable on all electrically conductive objects with ferromagnetic and non-ferromagnetic features
- Small sensor sizes
- High temperature range due to special materials used for sensor design
- Resistant to dirt, dust, moisture, oil, dielectric materials in the measuring gap and high pressures
- High measurement accuracy

Restrictions:

- Output signal and linearity depend on the electrical and magnetic characteristics of the target material
- Individual linearization and calibration are necessary
- Sensor cable length limited to 15m
- Sensor diameter and effective measurement spot diameter increase with larger measuring ranges



eddyNCDT 3060

eddyNCDT 3300



eddyNCDT 3001

eddyNCDT 3005

Performance eddyNCDT

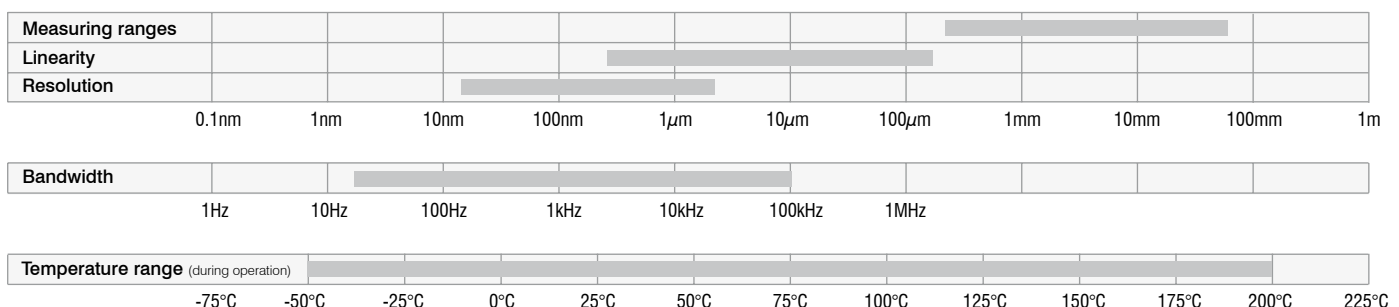

Capacitive measuring principle

The capacitive measuring principle is based on how an ideal plate-type capacitor operates. If an alternating current of constant frequency flows through the sensor capacitor, the amplitude of the alternating voltage on the sensor is proportional to the distance to the target (ground electrode).

In practice, due to the design of the sensors as guard ring capacitors, almost ideal linear characteristics are achieved.

However, a continuous dielectric constant between sensor and target is required for a constant measurement. Capacitive sensors also measure insulated materials. A linear output signal for insulators is also possible using an electronic circuit.

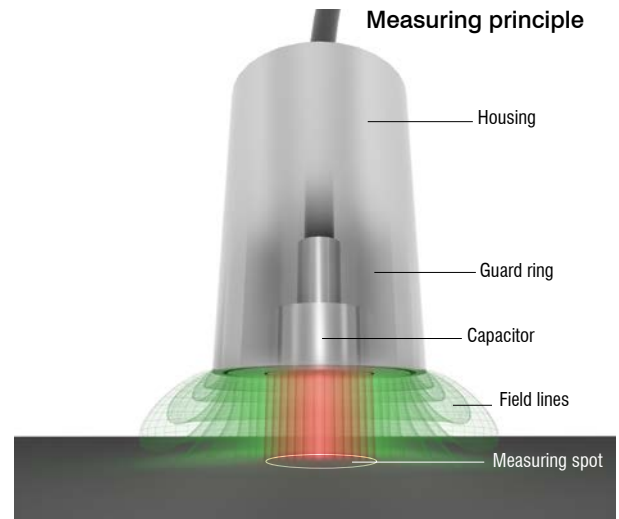

Advantages of capacitive sensors:

- Constant sensitivity and linearity for all conductive objects
- High temperature stability as housing is made from Invar and sensor is clamped on the abutting face
- Also applicable for insulating target material
- High geometric flexibility in terms of sensor design (measurement electrode)
- Nanometer resolution

Restrictions:

- Sensitivity to dielectric changes in the measuring gap (but measurements to micron accuracy are also possible in dusty and humid environments)
- Sensor diameter and effective measurement spot increase with larger measuring range



capaNCDT 6110



capaNCDT 6200



capaNCDT 6500

Performance capaNCDT

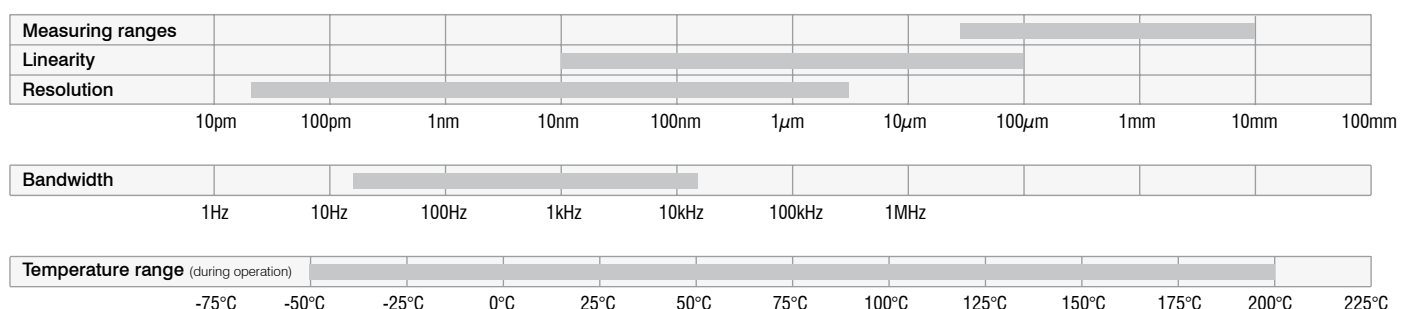

Laser triangulation

A laser diode emits a laser beam, which is aimed at the target. The ray reflected there is imaged via a lens either on a CCD/CMOS array or on a PSD element. The intensity of the reflected beam depends on the surface of the material. Therefore, the sensitivity is regulated for analog PSD sensors and the digital 1320/1420 series. With the digital 1750 and 2300 CCD sensors, the unique RTSC or Advanced RTSC features (Real Time Surface Compensation) regulate intensity changes in real time.

The distance from the object to the sensor is calculated from the position of the light spot on the receiver element. Depending on the sensor model, the data is evaluated using the external or internal controller and output via various interfaces.

Advantages:

- Small measurement spot diameter
- Large offset distance between measurement object and sensor
- Large measuring ranges
- Almost independent of material

Restrictions:

- Measurement accuracy is influenced by surface characteristics
- Clean environment required in beam path
- Large sensor dimension in relation to confocal, capacitive and eddy current sensors
- With reflecting surfaces, special models or special sensor alignment are required

Measuring principle

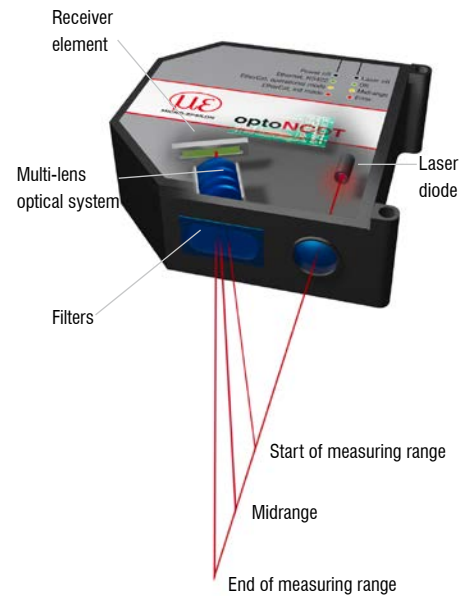

optoNCDT 1320/1420



optoNCDT 1750



optoNCDT 2300



optoNCDT 2300-2DR

Performance optoNCDT

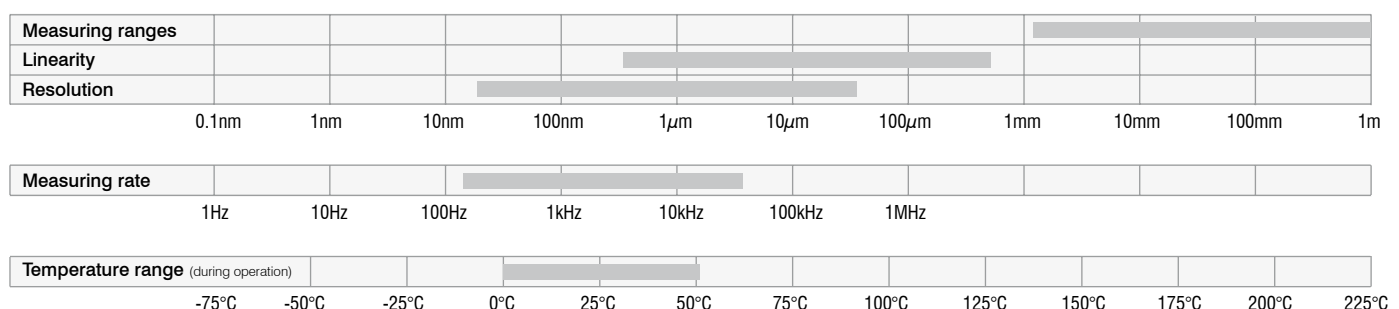

Confocal chromatic measuring principle

Polychromatic light (white light), starting from the light source in the evaluation unit, is transmitted to the sensor via an optical fiber. The lenses here are arranged so that the light in the longitudinal direction of the optical axis is broken down by controlled chromatic aberration into monochromatic wavelengths. This lens focuses the light beam onto the target surface. Depending on the distance, there are different spectral colors in the focus.

Only the wavelength which is exactly focused on the target is used for the measurement. The light reflected from this point is imaged by an optical arrangement onto a light sensitive sensor element, on which the associated spectral color is detected and evaluated. A defined distance point is assigned to each wavelength by factory calibration.

This principle enables measurements on practically all types of surface. A thickness measurement can even be made for transparent materials with a sensor, whereby the spectrum of the second surface is interpreted.

Advantages of confocal sensors:

- Extremely high resolution in the nanometer range
- Surface-independent measurement
- Extremely small, constant spot size
- Compact beam path
- One-sided thickness measurement with transparent measurement objects
- Radial measurement direction possible
- No laser safety regulations apply as white light is used

Restrictions:

- Limited distance between sensor and measurement object
- Clean environment required in beam path

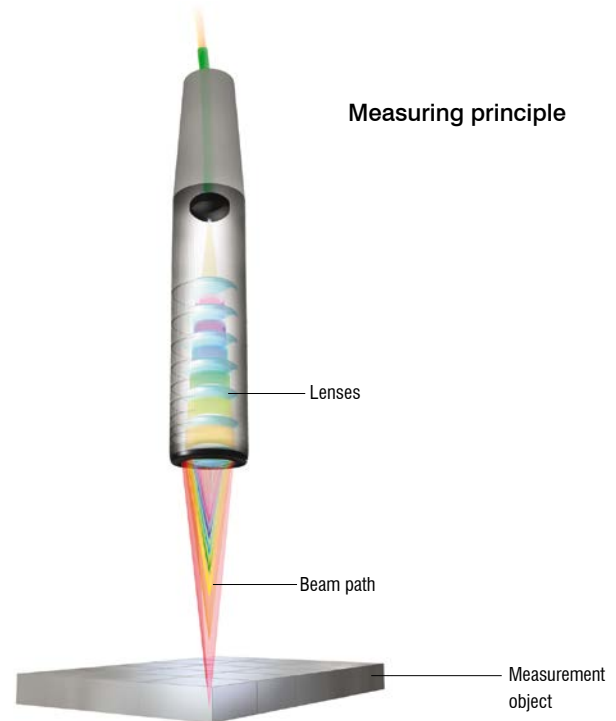

Performance confocalDT

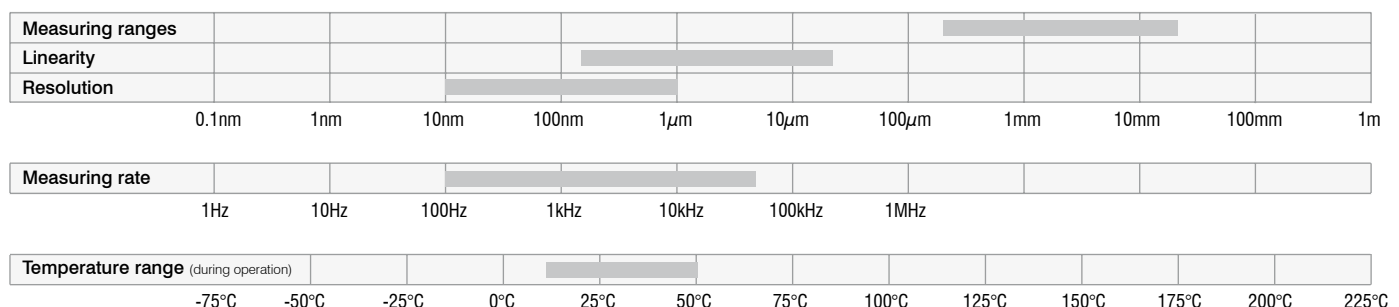

Glossary & Definitions

Temperature stability

The temperature stability indicates the percentage possible error in the measurement per unit (K or °C). This error is attributable to the physical expansion of built-in components or to the effect of temperature on electronic components.

This effect results in a slight deviation of the results at different temperatures.

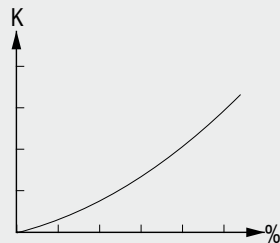

Measuring range

The measuring range describes the space of a sensor in which the object to be measured must be situated so that the specified technical data are satisfied. The extreme regions of this space are termed the start and end of the measuring range.

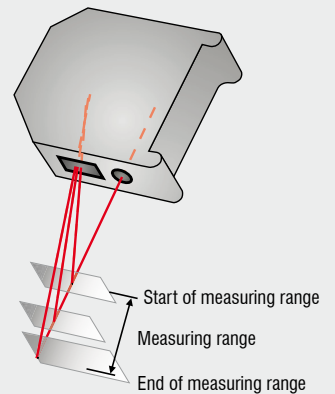

Temperature range (during operation)

The range of ambient temperature in which the sensor can be operated without permanent change to its performance data.

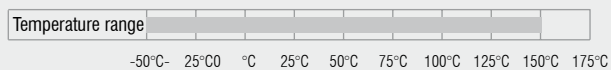

Resolution

The resolution describes the smallest possible change of a quantity which can be reliably measured by a sensor. In practice, the resolution is determined by the signal-to-noise ratio, taking into account the acquired frequency spectrum.

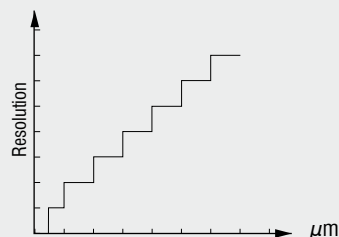

Non-linearity >> Linearity

The maximum deviation between an ideal straight-line characteristic and the real characteristic is termed the non-linearity or linearity. The figure is given as a percentage of the measuring range (% FSO).



Accuracy

The accuracy describes the maximum measuring error taking into account all the factors which affect the real measurement value. These factors include the linearity, resolution, temperature stability, long-term stability and a statistical error (which can be removed by calculation).

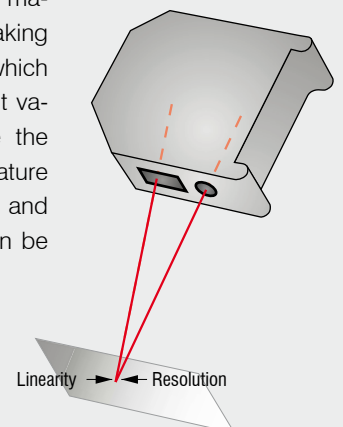

Glossary & Definitions

Sampling rate

The sampling rate is the frequency with which analog signals are sampled in time during an A/D conversion.

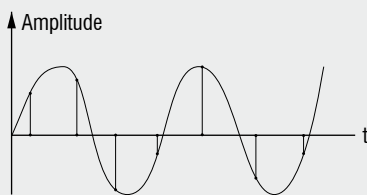

Response time

Response time is the time, how long a sensor needs to rise the signal output from 10 % to 90% of the value. With digital measurement devices, this is the time taken required to output a stable measurement value.

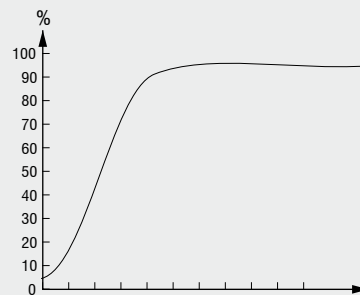

Reproducibility

Quantitative specification of the deviation of mutually independent measurements which are determined under the same conditions.

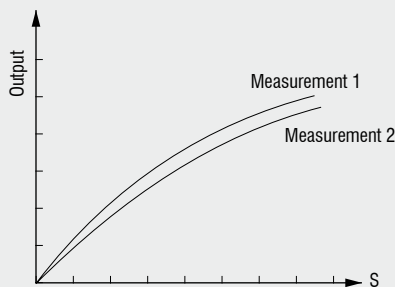

Signal-to-noise ratio

The quality of a transmitted useful signal can be stated with the signal-to-noise ratio.

Noise arises with any data transmission. The higher the separation between noise and useful signal, the more stable can the transmitted information be reconstructed from the signal. If, during the digital sampling, the noise power and the useful signal power come too close, an incorrect value may be detected and the information corrupted.

Application criteria & Performance data

All measurement technologies have different advantages and limitations. In order to simplify the decision for one the principles, these should now be compared with each other.

The table below shows each of the four measurement technologies described in this TechNote. The techniques dealt with represent only the technological basic principle. The different principles enable countless application possibilities and modifications.

Measuring procedure		Eddy current	Capacitive	Triangulation	Confocal
Accuracy		■	■	■	■
Resolution		■	■	■	■
Temperature range	up to 40°C	■	■	■	■
	up to 90°C	■	■	□	■
	up to 150°C	■	■	□	□
	more than 150°C	■	■	□	□
Sensor size		■	□	□	□
Spot size		□	□	■	■
Environmental compatibility		■	□	–	–
Measurement distance (long range)		□	–	■	–
Bandwidth/Measuring rate		■	□	■	■
Measurement object	Transparent objects	–	■	□	■
	Metals	■	■	■	■
	Insulators	–	□	■	■
	Surface structure	■	■	□	■
	Electric runout (inhomogeneous electromagnetic materials)	–	■	■	■

■ good □ neutral – limited

Technical Data		Eddy current	Capacitive	Triangulation	Confocal
Measuring ranges	mm	0.4 - 80	0.05 - 10	2 - 1000	0.3 - 30
Linearity	μm	0.4	0.01	0.6	0.15
Max. resolution	μm	0.02	0.0000375	0.03	0.01
Bandwidth/measuring rate	kHz	up to 100	up to 20	up to 50	up to 70
Temperature range (sensor)	°C	-50 ... +200	- 200 ... +200	0 ... +55	+10 ... +50
Temperature stability	% FSO/°C	< ± 0.015	< 0.0005	< 0.01	< 0.01