

SENSORS & SYSTEMS

Authority in Displacement Measuring

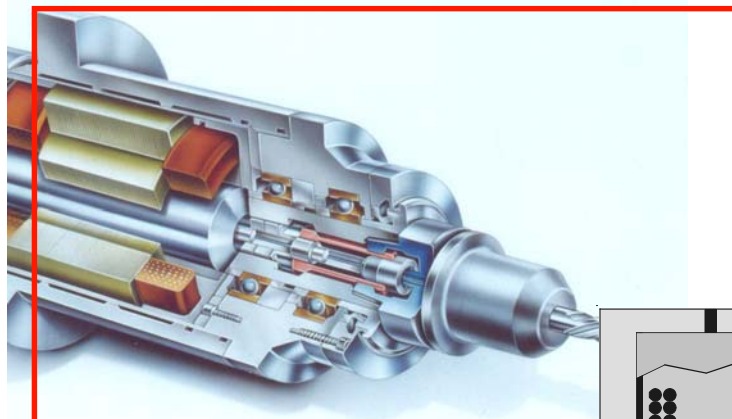

INSTRUMENTATION MICRO EPSILON



Digital Eddy-Current
Measuring System for
Spindle Growth System

SGS 4311
eddyNCDT

**MICRO-EPSILON
MESSTECHNIK**
GmbH & Co. KG
Koenigbacher Strasse 15

D-94496 Ortenburg

Tel. +49/85 42/1 68-0
Fax +49/85 42/1 68-90
e-mail info@micro-epsilon.de
www.micro-epsilon.com



Certified acc. to DIN EN ISO 9001: 2000



MICRO-EPSILON

Content

1.	Safety	5
1.1	Symbols Used	5
1.2	Warnings	5
1.3	Notes on CE Identification	6
1.4	Proper Use	7
1.5	Proper Environment	7
2.	System Description	8
2.1	Measurement Principle	8
2.2	Structure of the Measurement System	8
2.3	Controller Connectors	9
2.4	Glossary	9
2.5	Technical Data	10
3.	Delivery	11
3.1	Supplied Items, Unpacking	11
3.2	Storage	11
4.	Installation and Assembly	12
4.1	Precautions	12
4.2	Sensor	12
4.3	Sensor Cable	13
4.4	Controller	14
4.5	Connecting the Measurement System	15
5.	Operation	16
6.	Warranty	16
7.	Decommissioning, Disposal	16
8.	Appendix	17



MICRO-EPSILON





1. Safety

Knowledge of the operating instructions is a prerequisite for equipment operation.

1.1 Symbols Used

The following symbols are used in this instruction manual:



DANGER!

- **imminent danger**



WARNING!

- **potentially dangerous situation**



IMPORTANT!

- **useful tips and information**

1.2 Warnings

- Avoid banging and knocking the sensor and the controller
⇒ Damage to or destruction of the sensor and/or controller
- The power supply must be connected in accordance with the safety regulations for electrical equipment
⇒ Damage to or destruction of the sensor and/or controller
- Protect the cable against damage
⇒ Failure of the measuring device



MICRO-EPSILON

1.3 Notes on CE Identification

The following applies to the SGS4311 measuring system:

EC regulation 89/336/EEC

Products which carry the CE mark satisfy the requirements of the EC regulation EC 89/336/EEC 'Electromagnetic Compatibility' and the European standards (EN) listed therein.

The EC declaration of conformity is kept available according to EC regulation, article 10 by the authorities responsible at

MICRO-EPSILON MESSTECHNIK
GmbH & Co. KG
Koenigbacher Straße 15

D-94496 Ortenburg

The system is designed for use in industry and satisfy the requirements of the standards

- EN 50 081-1 RFI emission
- EN 61 000-6-2 Immunity to interference

The systems satisfy the requirements if they comply with the regulations described in the instruction manual for installation and operation.



1.4 Proper Use

- The system is designed for use in industrial areas.
- It is used
 - displacement, distance, thickness and movement measurement
 - position measuring of parts or machine components
- The sensors may only be operated within the limits specified in the technical data (chap. 2).
- The system should only be used in such a way that in case of malfunction or failure personnel or machinery are not endangered.
- Additional precautions for safety and damage prevention must be taken for safety-related applications.

1.5 Proper Environment

- Operating temperature
 - Sensor, sensor cable: 0 to +70 °C (+32 to +158 °F)
 - Controller: +10 to +50 °C (+50 to +122 °F)
- Humidity: 5 - 95 % (no condensation)
- Ambient pressure: atmospheric pressure
- EMC: Acc. to EN 50 081-1 RFI emission
EN 61000-6-2 Immunity to interference
- Storage temperature -25 to +75 °C (-13 to +167 °F)



MICRO-EPSILON

2. System Description

2.1 Measurement Principle

The eddyNCDT SGS4311 (Non-Contacting Displacement Transducers) measurement system operates on the basis of eddy currents without making physical contact. It is used for measurements on objects consisting of electrically conducting materials which have ferromagnetic properties.

High frequency alternating currents flow through a coil cast in a sensor housing. The electromagnetic field from the coil induces eddy currents in the electrically conducting measurement object, causing the alternating current resistance of the coil to change. This change of impedance delivers an electrical signal proportional to the distance of the measurement object from the sensor.

The controller conditions the sensor signals ready for the user.

2.2 Structure of the Measurement System

The displacement measuring system SGS is developed for recording the extension of high-speed milling spindles. This enables the active compensation of the axial spindle extension via CNC-machine tool.

The sensor will be integrated in the spindle. The sensor is controlled by an electronics with a DSP (digital signal processor). All sensor-specific data are stored in the sensor (EEPROM). After changing the spindle, the system is ready to run without any calibration.



IMPORTANT!

If the spindle/sensor or controller/sensor cable ECM6 have been changed a calibration of the system is not necessary.

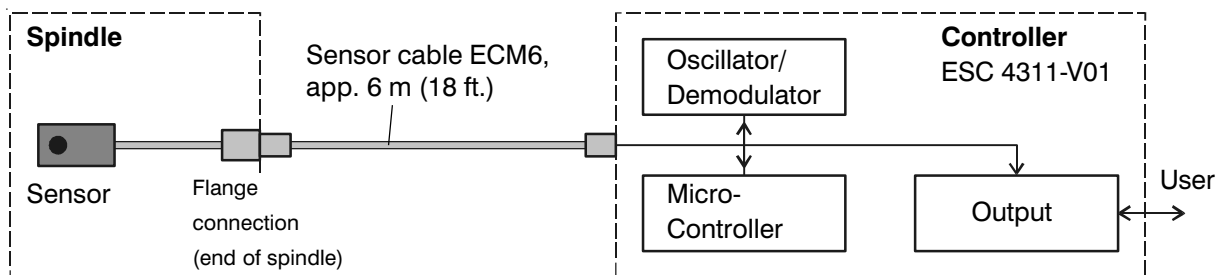

Fig. 2.1: Block diagram

The sensor cable ECM6 and the electronics ESC4311-V01 are adjusted to each other. The serial number has to be the same.



2.3 Controller Connectors

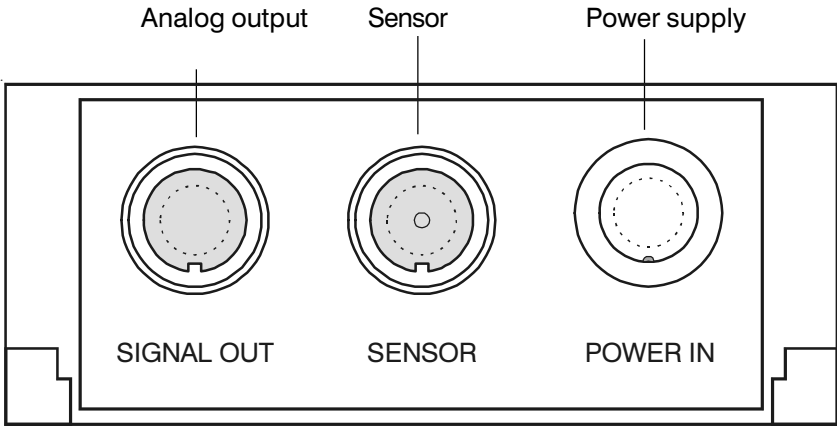
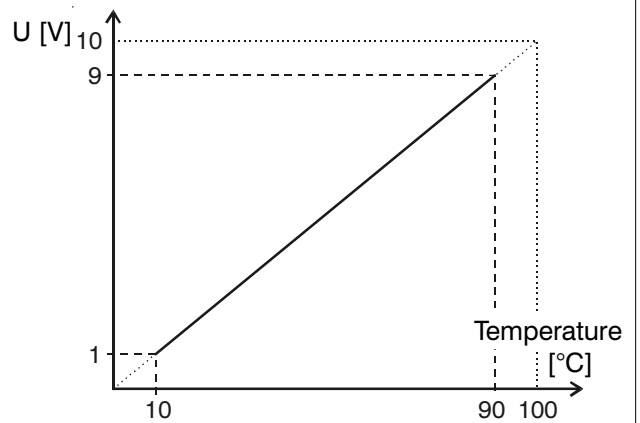
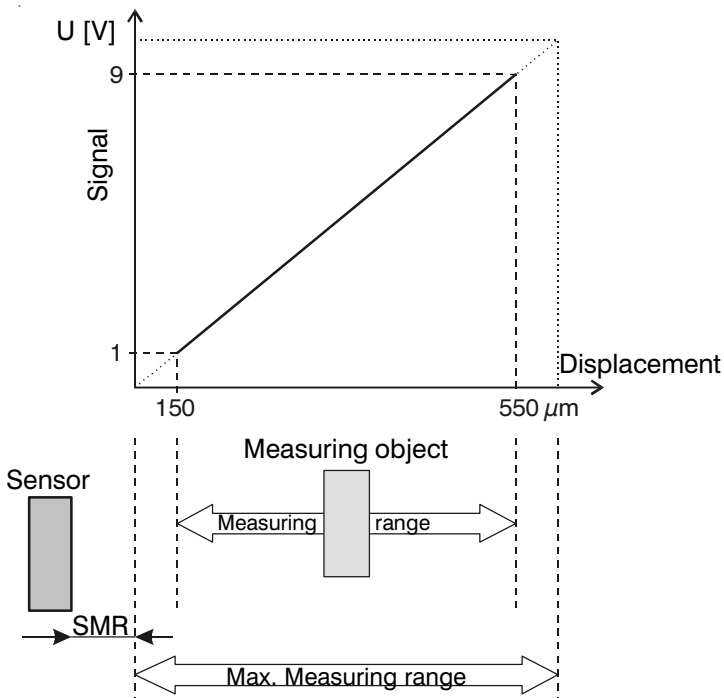

Fig. 2.2: Connectors on the rear side of the controller

2.4 Glossary

- SMR Start of measuring range. Minimum distance between sensor front and measuring object
- MMR Midrange
- EMR End of measuring range (Start of measuring range + measuring range). Maximum distance between sensor front and measuring object.
- MR Measuring range



■ = specified range



2.5 Technical Data

System		SGS 4311-V01-EM U04-C680	
Measuring range MR	μm	400	
Start of measuring range SMR	μm	ca. 150	
Linearity	μm	± 5	
Resolution	μm	1	
Frequency response	analog	0.1 ... 100 Hz ¹	
Sensitivity	displacement	mV/ μm	20
	temperature	V/ $^{\circ}\text{C}$	0.1
Temperature stability	Sensor Controller	± 0.01 % FSO/ $^{\circ}\text{C}$ ± 0.05 % FSO/ $^{\circ}\text{C}$	
Operating temperature	Sensor +Cable	$^{\circ}\text{C}$	0 ... +70 (+32 ... +158 $^{\circ}\text{F}$)
	Controller	$^{\circ}\text{C}$	10 ... 50 (+50 ... +122 $^{\circ}\text{F}$)
Storage temperature		-25 ... 75 $^{\circ}\text{C}$ (-13 ... +167 $^{\circ}\text{F}$)	
Interfaces	analog digital	0.2 ... 10 VDC (Option: 4 ... 20 mA) on request	
Temperature output	VDC	0.2 ... 10	
Protection class	Controller	IP67 (housing: Aluminum)	
Power supply		+24 VDC	
Sensor		EMU 04-C080, sensor parameter are stored in EEPROM, temperature sensor integrated in the sensor housing	
Sensor replacement		Sensor specific data are read out automatically from the sensor EEPROM	
Sensor cable length	Sensor ECM6	0,8 m 6 m	
Electromagnetic compatibility		acc. EN 50081-2 / EN 61000-6-2	

FSO = Full-Scale Output

1) Other frequencies on request

The quoted data applies at a reference temperature of 20 $^{\circ}\text{C}$ (70 $^{\circ}\text{F}$).



3. Delivery

3.1 Supplied Items, Unpacking

Check for completeness and shipping damages immediately after unpacking.
The delivery includes:

Sensor:

- 1 Sensor with flange connector, sealing ring and protecting cap

Controller:

- 1 Controller ESC4311-V01
- 1 Instruction manual
- 1 Sensor cable ECM6

If any item has been damaged or omitted, please contact MICRO-EPSILON or your supplier immediately.

3.2 Storage

Storage temperature -25 ... 75 °C (-13 to +167 °F)

Humidity: 5 - 95 % (non-condensing)



MICRO-EPSILON

4. Installation and Assembly

4.1 Precautions

No sharp or heavy objects should be allowed to affect the cable sheath of the sensor cable, the supply cable and of the output cable. All plug-in connections must be checked for firm seating before starting operation.

4.2 Sensor

Design: The front part of the sensor with embedded coil consists of electrically non-conducting materials.

Legend:
mm
(inches)

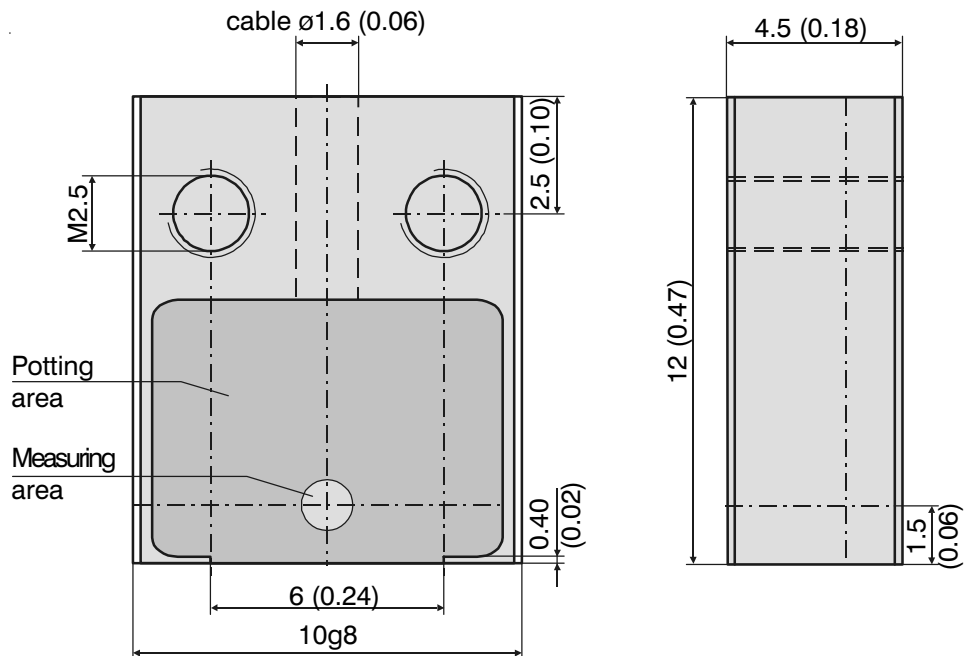

Fig. 4.1: Sensor dimensions, not to scale

Start of Measuring Range

For each sensor a minimum distance to the measurement object must be maintained. This avoids a measurement uncertainty due to the sensor pressing on the measurement object and mechanical damage to the sensor/measurement object.

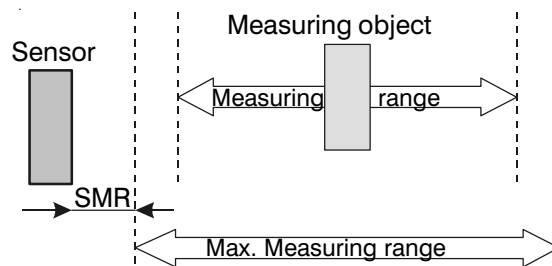

Fig. 4.2: Start of measuring range (SMR), the smallest distance between sensor face and measuring object.



Measuring area

The minimum measuring area must have a diameter of 6 mm or greater for an eddy-current sensor. If you underrun the minimum measuring area no reproducibly measurements are possible. The special calibration of the system can be done by MICRO-EPSILON if the measuring area not satisfy this specifications.

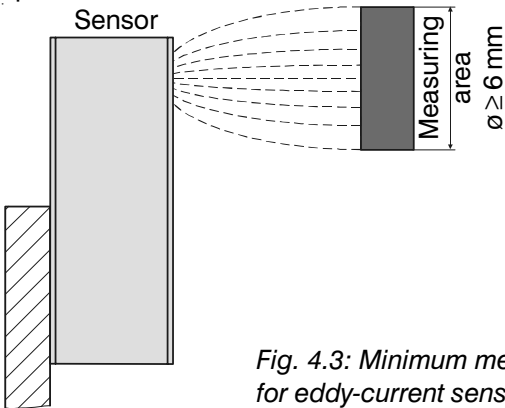

Fig. 4.3: Minimum measuring area for eddy-current sensors

4.3 Sensor Cable

- Lay the cable such that no sharp-edged or heavy objects can affect the cable sheath.
- Do not kink the cable - see Fig. 4.4 for the minimum bending radius.

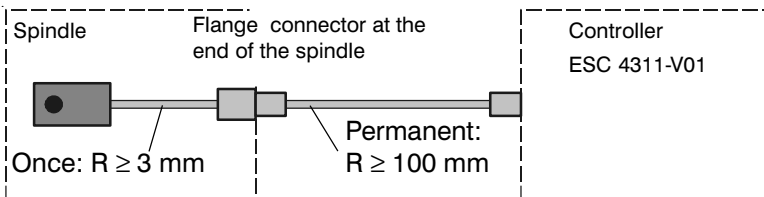
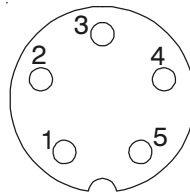

Fig. 4.4: Minimum bending radius for sensor cables

- Mount the 5-pin flange connector at the end of the spindle. Do not forget the sealing between the connector and the housing (see chap. 7)!

- PIN 1 red
- PIN 2 yellow
- PIN 3 total screen
- PIN 4 screen coaxial cable
- PIN 5 inner conductor



5-pin flange connector, solder pin side

Fig. 4.5: Pin assignment for the sensor EMU04 series on the 5-pin flange connector



WARNING!

Do not shorten the sensor cable. Loss of functionality!



MICRO-EPSILON

- Make the connection between the sensor and controller using the sensor cable (type ECM6). Connect the sensor cable at the rear side of the controller (see Fig. 4.6). Check the plugged connections for firm seating.

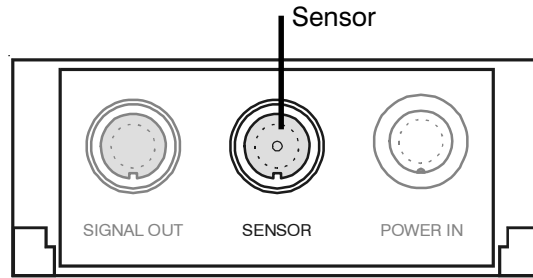

Fig. 4.6: Rear side of the controller

4.4 Controller

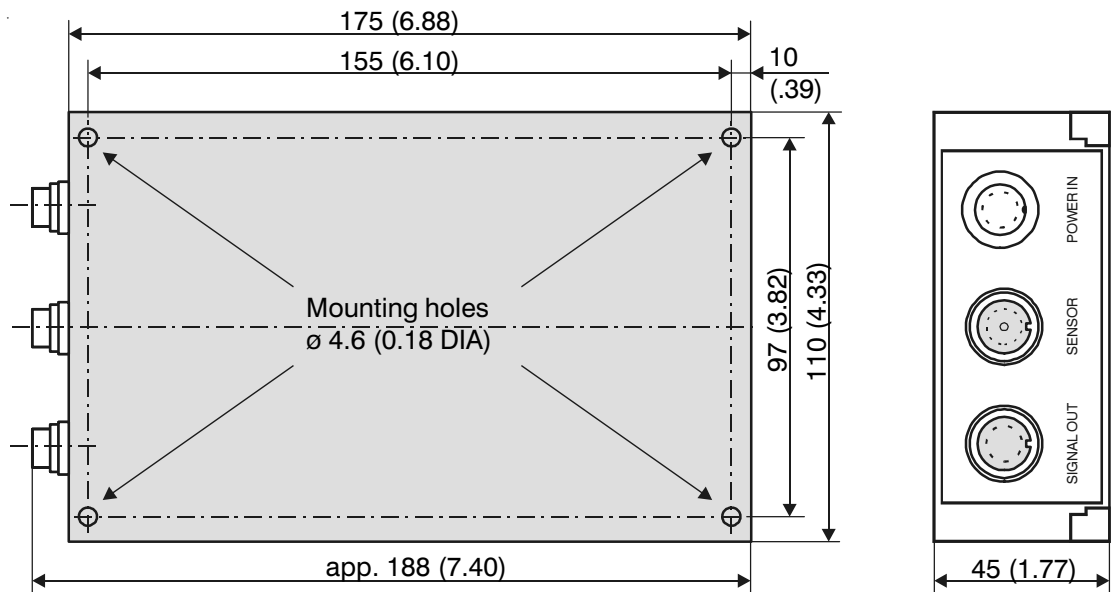

Fig. 4.7: Dimensions and mounting method for controller, not to scale

The controller is mounted with M4 screws (accord. to DIN912).

Legend:
mm
(inches)



4.5 Connecting the Measurement System

Provide the **power supply** for the controller. To do this connect

- 1) 8-pin connector (Power IN, Fig. 4.8, 4.10) with a
- 2) power supply 24 VDC / $\pm 15\%$

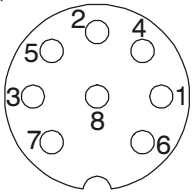

- PIN 4 +24 VDC
- PIN 5 Ground (24 VDC)

Fig. 4.8: 8-pin female connector for power supply, solder pin side

Connect the **measurement signal displays** and **recording devices** to the controller. To do this connect

- 1) 8-pin female connector (SIGNAL OUT, Fig. 4.9, 4.10) with the
- 2) **measurement signal display** resp. **recording device**

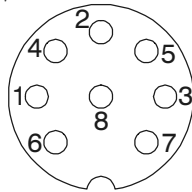

- PIN 1 Ground
- PIN 2 Temperature signal (0 ... +10 VDC) at 0 ... +100 °C
- PIN 4 Ground
- PIN 5 Displacement signal (0 ... +10 VDC) at 0 ... 500 μm

Fig. 4.9: 8-pin connector for signal output, solder pin side

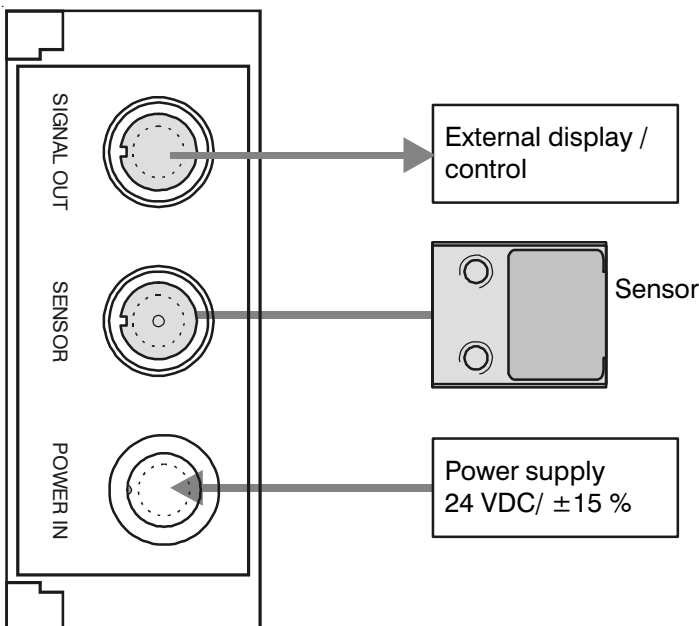

Fig. 4.10: Measurement setup



WICHTIG!

Optional Accessory
PC4311-3:
Power cable, 3 m long with 8-pin female connector respectively free leads, for power supply of the SGS controller type ESC4311-V01 with 24 VDC.



WICHTIG!

Optional Accessory
SCA4311-3:
Signal cable, 3 m long with 8-pin male connector and two BNC male connectors, for spindle extension and temperature signal, SGS controller type ESC4311.



MICRO-EPSILON

5. Operation

The system is ready for operation. There are no adjustments which must be done by the user. MICRO-EPSILON recommends to let the system warm up for about 30 minutes.

6. Warranty

All components of the device have been checked and tested for perfect function in the factory.

In the unlikely event that errors should occur despite our thorough quality control, this should be reported immediately to MICRO-EPSILON.

The warranty period lasts 12 months following the day of shipment. Defective parts, except wear parts, will be repaired or replaced free of charge within this period if you return the device free of cost to MICRO-EPSILON.

This warranty does not apply to damage resulting from abuse of the equipment and devices, from forceful handling or installation of the devices or from repair or modifications performed by third parties.

Repairs must be exclusively done by MICRO-EPSILON.

No other claims, except as warranted, are accepted. The terms of the purchasing contract apply in full.

MICRO-EPSILON will specifically not be responsible for eventual consequential damage.

MICRO-EPSILON always strives to supply its customers with the finest and most advanced equipment. Development and refinement is therefore performed continuously and the right to design changes without prior notice is accordingly reserved.

For translations in other languages, the data and statements in the German language operation manual are to be taken as authoritative.

7. Decommissioning, Disposal

- Disconnect the power supply and output cable on the controller.
- Disconnect the sensor cable between sensor and controller.

The SGS4311 is produced according to the directive 2002/95/EC („RoHS“). The disposal is done according to the legal regulations (see directive 2002/96/EC).



8. Appendix

5-pin connector at the end of the spindle
 dimensions in mm (inches), not to scale



Flange connector, Type Binder, Series 712, soldered joint

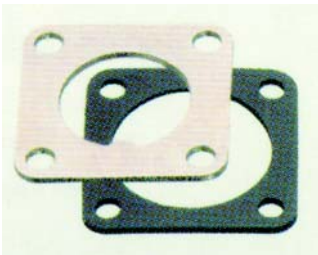
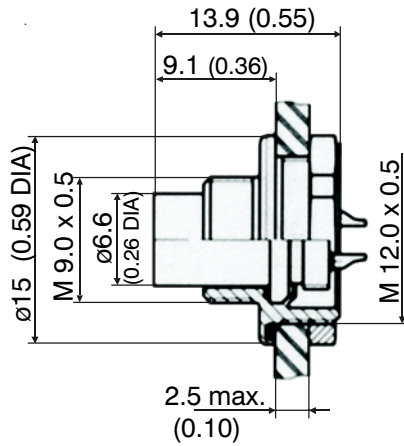

Rectangle flange with sealing

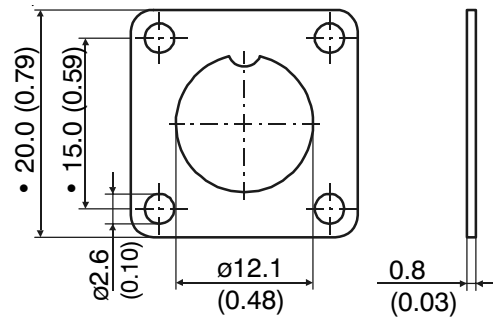

Legend:
 mm
 (inches)

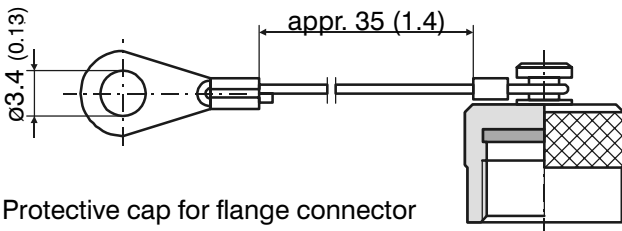
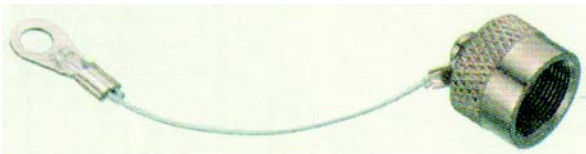

Protective cap for flange connector

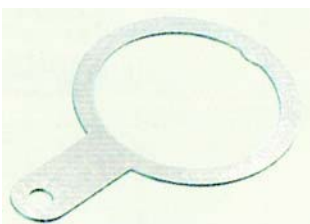

Soldering eyelet



MICRO-EPSILON

Optional Accessory

- PC4311-3 Power cable, 3 m long
with 8-pin female connector respectively free leads,
for power supply of the SGS controller
type ESC4311-V01 with 24 VDC
- SCA4311-3 Signal cable, 3 m long
with 8-pin male connector and two BNC male connectors,
for spindle extension and temperature signal,
SGS controller type ESC4311