

A007

Eddy current sensors

eddyNCDT

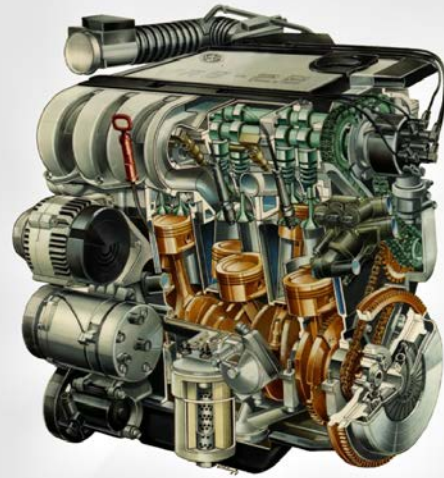

Piston secondary movement and piston ring position

To improve the construction of internal combustion engines and damage analyses, it is necessary to measure the thermal and mechanical loads in the engine. Two important variables here are the transverse movement of the piston (secondary movement) and the movement of the piston rings during the individual operating strokes. The measurements must be carried out under operating conditions in order to provide reliable results. To do this, the engine is run on the bench either in firing or mode or in towing operation.

Requirements for the measurement system

- Measuring range: 0 - 0.5mm
- Response: less than $1\mu\text{m}$
- Miniature sensor
- Very thin interconnecting cable
- Temperature stable

Ambient conditions

- Temperature to 150 (180°C)
- Oil, petrol air-mixture
- Combustion gases
- Vibrations and pressure

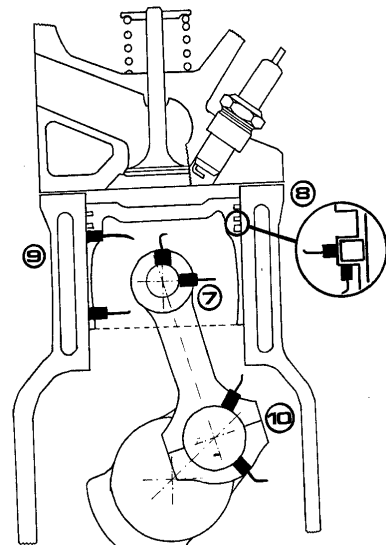

The sensor cable must be laid from the moving piston to the engine block by a special crank arm

